

# TRANSDUCER INSTALLATION MANUAL

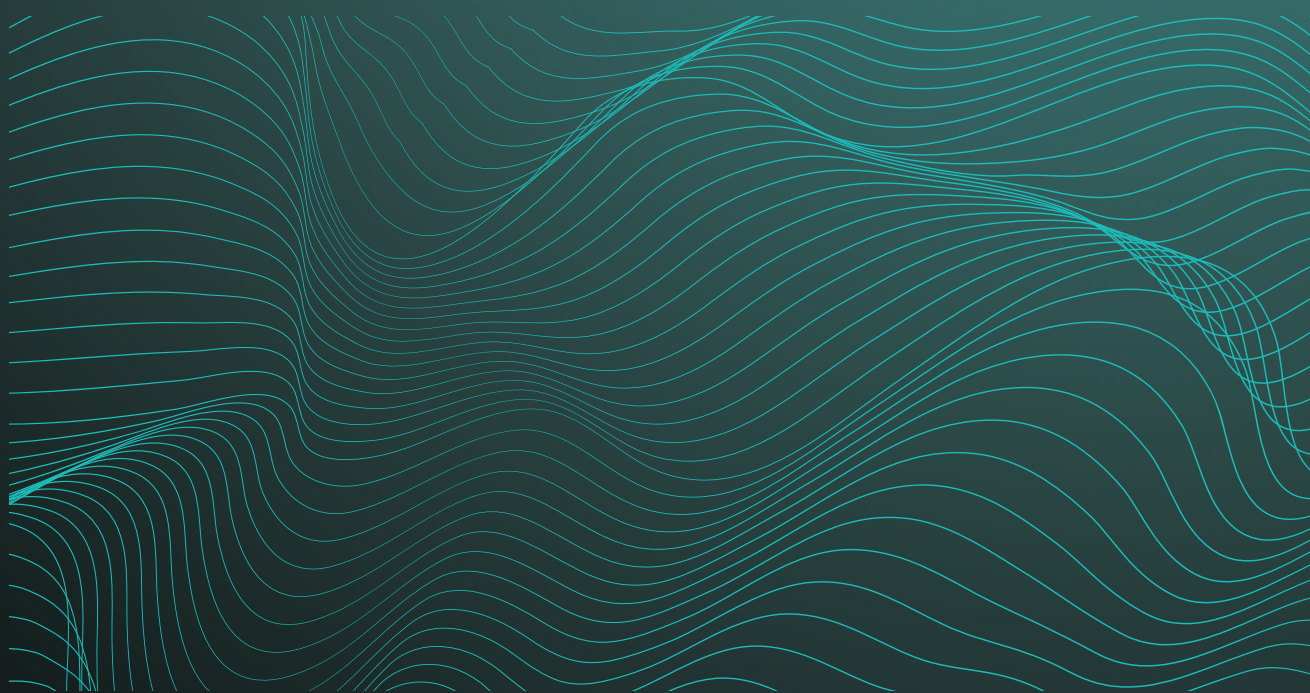

SEE IT ALL

# WASSP TRANSDUCER INSTALLATION MANUAL

This installation manual covers the installation recommendations for the WASSP 160kHz, WASSP 80kHz and WASSP Wideband Fairing Transducer 90-190kHz.

This manual does not cover installation and setup of any associated WASSP system components.

## DOCUMENT REVISION HISTORY

REVISION DATE	REASON FOR CHANGE	VERSION
April 2016	Compilation	1.0
June 2016	Added Technical Specification and updates	1.1
June 2017	Corrected typos in Figures 3 & 4 and Section 4	1.2
July 2017	Update Section 5.2 Mounting the Cable Gland	2.0
August 2017	Addition of Ceramic Discharge Procedure	2.1
December 2017	Update Section 8 Technical Specifications	2.2
May 2019	Update Section 7 Cable Connection to DRX	2.3
February 2020	Added Section 6 Fairing Installation	2.4
May 2020	Update Wideband Fairing Transducer 90-190kHz	2.5

## RELATED DOCUMENTS

- » WMB-X230 Installation Manual
- » WMB-3250 Installation Manual
- » WASSP DRX Installation Manual

Further documentation and updated specifications and installation manuals can be found at [wassp.com](http://wassp.com)

## GENERAL NOTICES

WASSP Ltd. reserves the right to change the contents of this manual and any system specifications without notice.

Contact WASSP Ltd. regarding copying or reproducing this manual.

## SAFETY NOTICES

The installer of the equipment is solely responsible for the correct installation of the equipment. WASSP Ltd. holds no responsibility for any damage associated with incorrect installation.

## SUPPORT INFORMATION

For details on Registration, Support and Resources see "9 Product Registration, Support and Resources" on page 31.

## WARNINGS, CAUTIONS AND NOTES

Warnings, cautions and notes are indicated by the following icons throughout this manual:



**WARNING** indicates that if the instruction is not heeded, the action may result in loss of life or serious injury.



**CAUTION** indicates that if the instruction is not heeded, the action may result in equipment damage or software corruption.



**NOTE** indicates a TIP or additional information that can be helpful while performing a procedure.

## CONTENTS

<b>1 Introduction</b>	<b>5</b>
<b>2 Transducer Dimensions</b>	<b>6</b>
2.1. 160kHz Transducer	6
2.2. 80kHz Transducer	7
2.3. Wideband Fairing Transducer 90-190kHz	8
<b>3 Mounting Options</b>	<b>9</b>
3.1. Through Hull Mounting	9
3.2. Pole Mounting	10
<b>4 Hull Mounting Considerations</b>	<b>11</b>
<b>5 Mounting Assembly</b>	<b>13</b>
5.1. 160kHz Transducer Mounting	13
5.2. 80kHz Transducer Mounting Assembly	15
5.3. Wideband Fairing Transducer 90-190kHz Mounting	18
<b>6 WASSP Wideband Fairing Transducer 90-190kHz Installation</b>	<b>19</b>
6.1. Measure and Preparation	20
6.2. Mounting the Fairing	21
6.3. Fairing Installation	22
6.4. Transducer Installation	23
<b>7 Cable Installation</b>	<b>24</b>
7.1. Gland Assembly	24
7.2. Mounting the Cable Gland	24
7.3. Transducer Cable	27
7.3.1. Replacing / Repairing an RJ-45 Connector	28
<b>8 Cable Connection to DRX</b>	<b>29</b>
<b>9 Technical Specification</b>	<b>31</b>
<b>10 Product Registration, Support and Resources</b>	<b>31</b>

## FIGURES

<b>Figure 1. 160kHz Transducer Dimensions</b>	<b>6</b>
<b>Figure 2. 80kHz Transducer Dimensions</b>	<b>7</b>
<b>Figure 3. Wideband Fairing Transducer 90-190kHz Dimensions</b>	<b>8</b>
<b>Figure 4. Through Hull Transducer Mounting</b>	<b>9</b>
<b>Figure 5. Positioning the Transducer on the Vessel Hull</b>	<b>9</b>
<b>Figure 6. Pole Transducer Mounting</b>	<b>10</b>
<b>Figure 7. Transducer mounting locations for larger displacement hulls</b>	<b>12</b>
<b>Figure 8. Alloy / Plastic Gland Assembly Outline and Dimensions</b>	<b>24</b>

<b>Figure 9. Mounting the Gland Assembly</b>	<b>25</b>
<b>Figure 10. Gland nut travel measurement point for acetal and aluminium glands</b>	<b>26</b>
<b>Figure 11. Gland nut travel measurement point for steel glands</b>	<b>26</b>
<b>Figure 12. Gland Assembly - Cable Connectors</b>	<b>27</b>
<b>Figure 13. DRX with the Transducer Receive Discharge cover label instruction</b>	<b>29</b>
<b>Figure 14. Ceramic Discharge Module</b>	<b>29</b>
<b>Figure 15. Discharging Transducer Channels</b>	<b>30</b>

## 1 INTRODUCTION

The WASSP system supports several different transducer types intended to be either pole, keel, thru hull or tank mounted. Finite measurements and fabrication should be based on the physical transducer to allow for manufacturing tolerances.

The transducer is supplied standard with a 10m cable. Different cable lengths such as 5m and 20m are available. Please ask your WASSP representative for more details.

### Pocket mount Transducers

The WASSP 160kHz and WASSP 80kHz transducers are rectangular-shaped transducer for keel and tank/pocket mounting, encased in a sealed sea chest. A sea chest for housing and sealing the transducer should be designed and constructed by a reputable shipyard to suit the size and contours of the hull of each individual vessel.

This must be sized and constructed accurately. The sea chest provides a stable platform for the transducer and must be mounted as horizontal to the vessel's waterline as possible.

A WASSP gland in alloy, plastic or steel are available for the the transducer cable through-hull seal.

### Thru-Hull Transducer

The WASSP Wideband Fairing Transducer 90-190kHz is available with a fairing that can be cut into a suitable shape for the hull of the ship with a dead rise of up to 30 degrees.

The Fairing Transducer 90-190kHz can allow WASSP operation at up to 20kn (installation dependant). The maximum vessel speed to be performed is 40 kn.

This transducer can also be used for a pole mount solution.

This Manual covers the following transducers:

- » WASSP 160 kHz
- » WASSP 80 kHz
- » WASSP Wideband Fairing Transducer 90-190kHz (WSP-503-160-10)

## 2 TRANSDUCER DIMENSIONS

The following drawings give the overall dimensions of the WASSP Transducer. The recommended cut-out dimensions for a mounting plate are also shown. Final cut-out dimensions should be based on actual transducer measurement.

### 2.1. 160KHZ TRANSDUCER

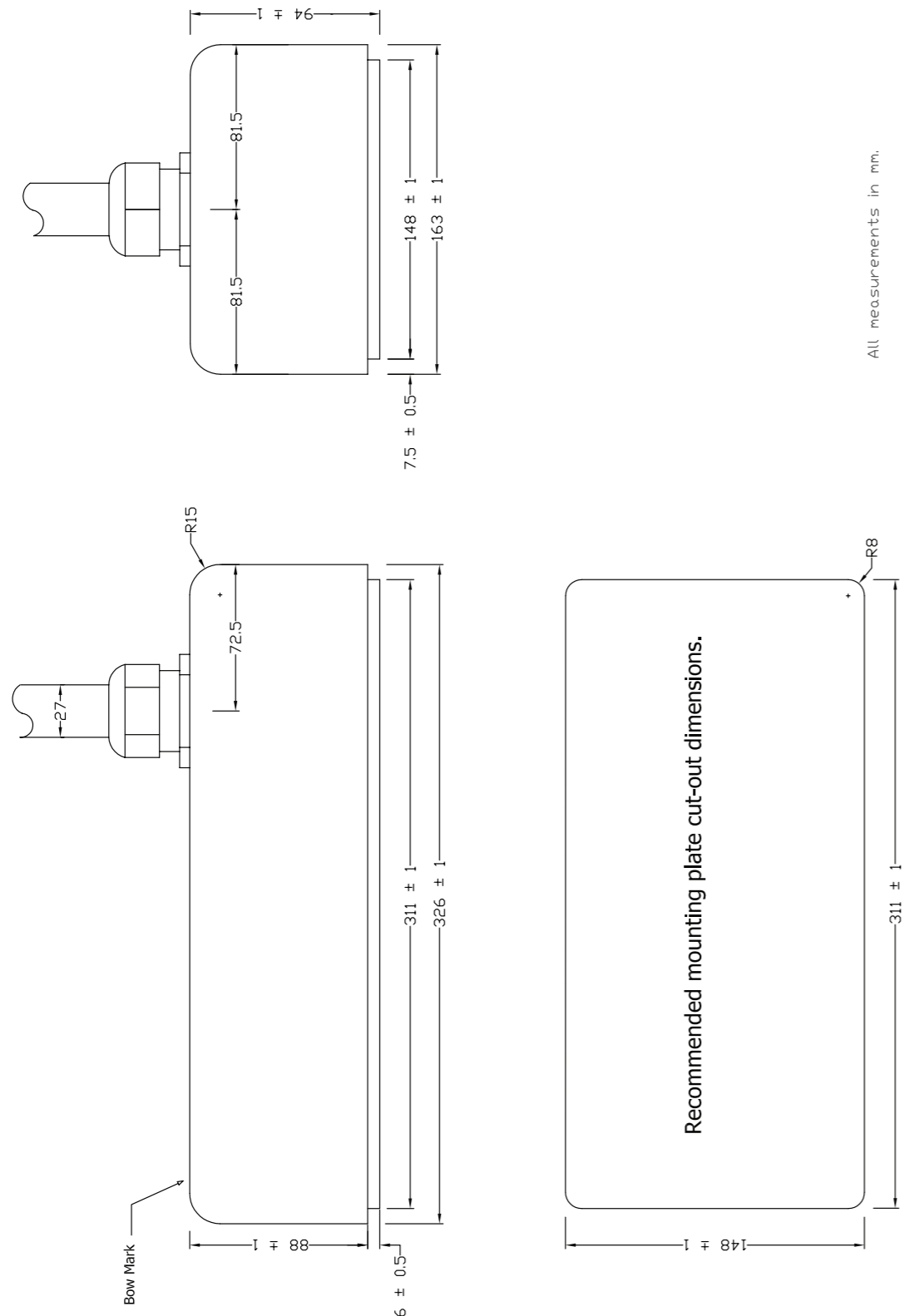

Figure 1. 160kHz Transducer Dimensions

### 2.2. 80KHZ TRANSDUCER

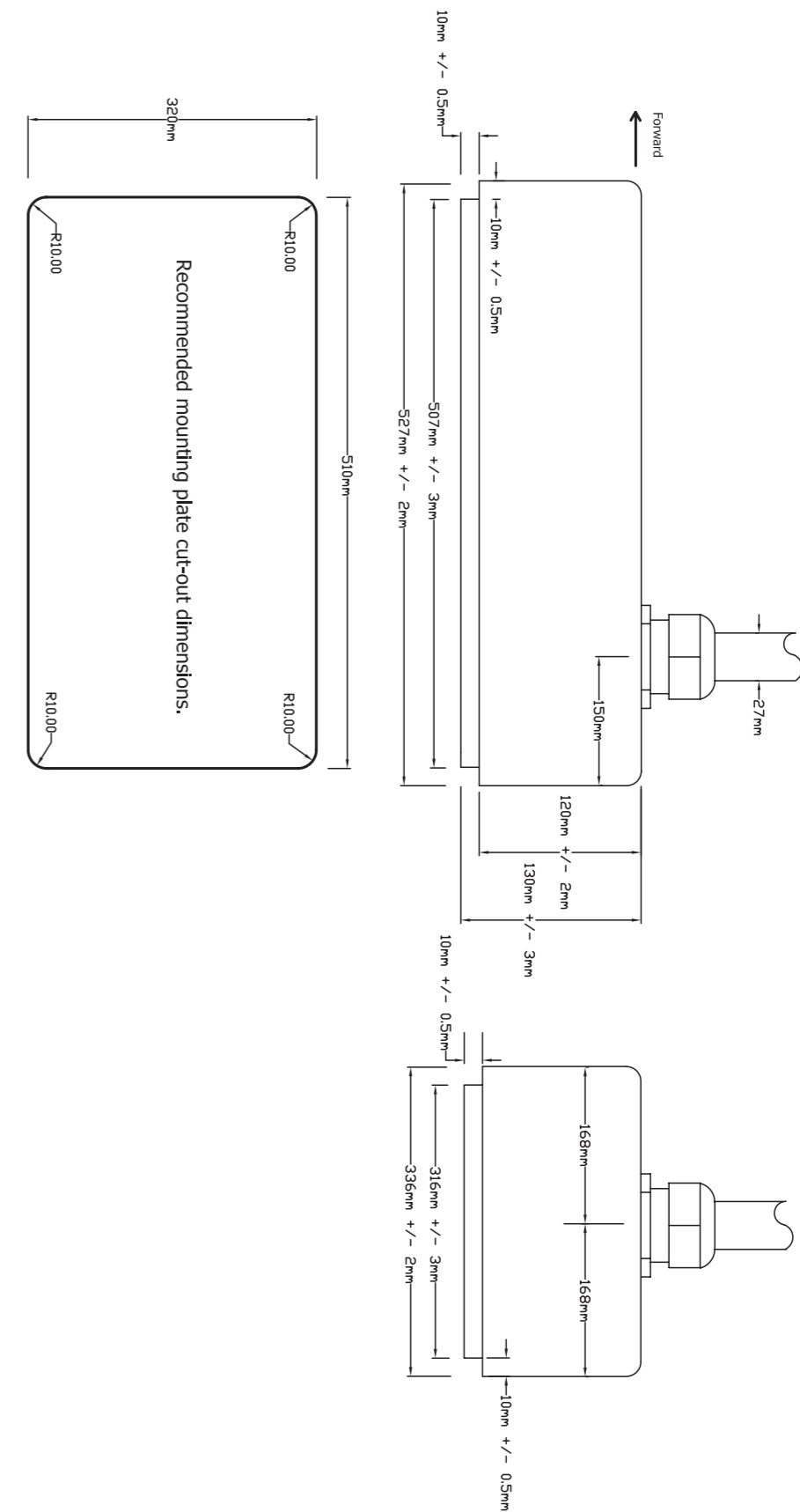

Figure 2. 80kHz Transducer Dimensions

### 2.3. WIDEBAND FAIRING TRANSDUCER 90-190KHZ

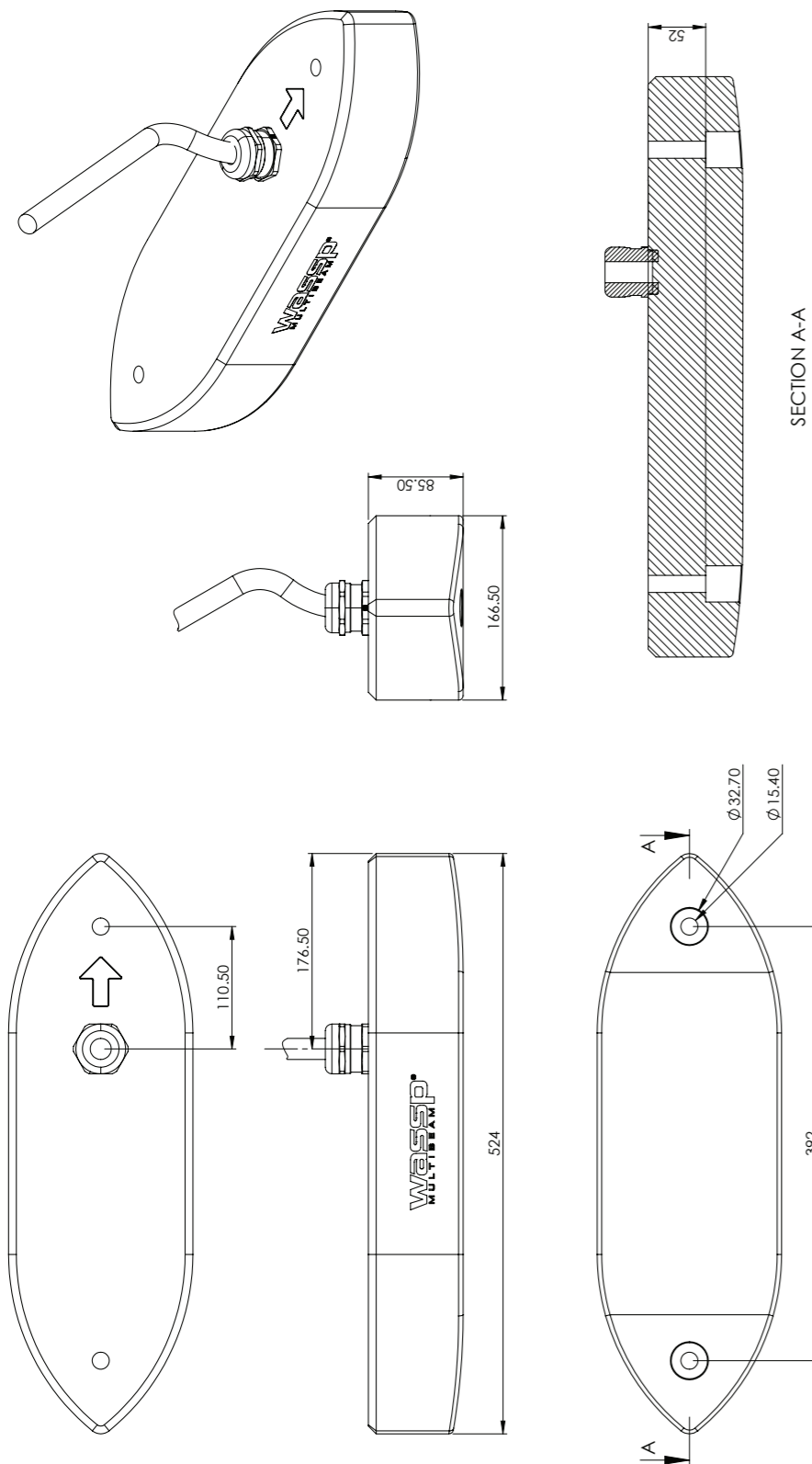

Figure 3. Wideband Fairing Transducer 90-190kHz Dimensions

### 3 MOUNTING OPTIONS

#### 3.1. THROUGH HULL MOUNTING

When mounting the transducer, ensure it is accurately running parallel to the keel. See below.

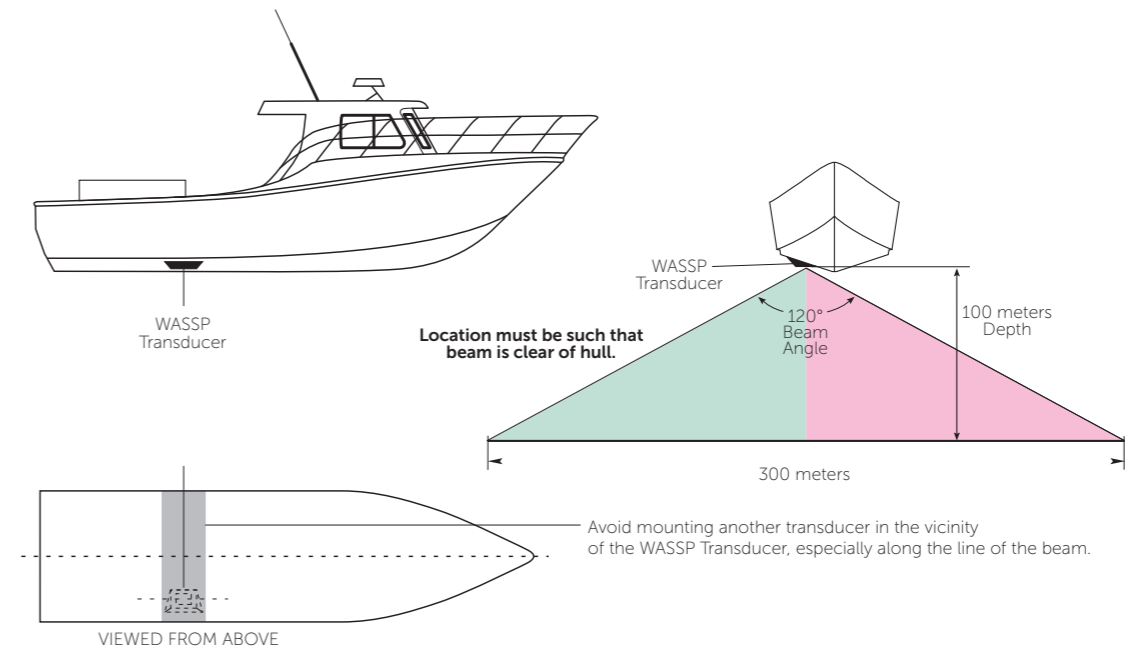

Figure 4. Through Hull Transducer Mounting

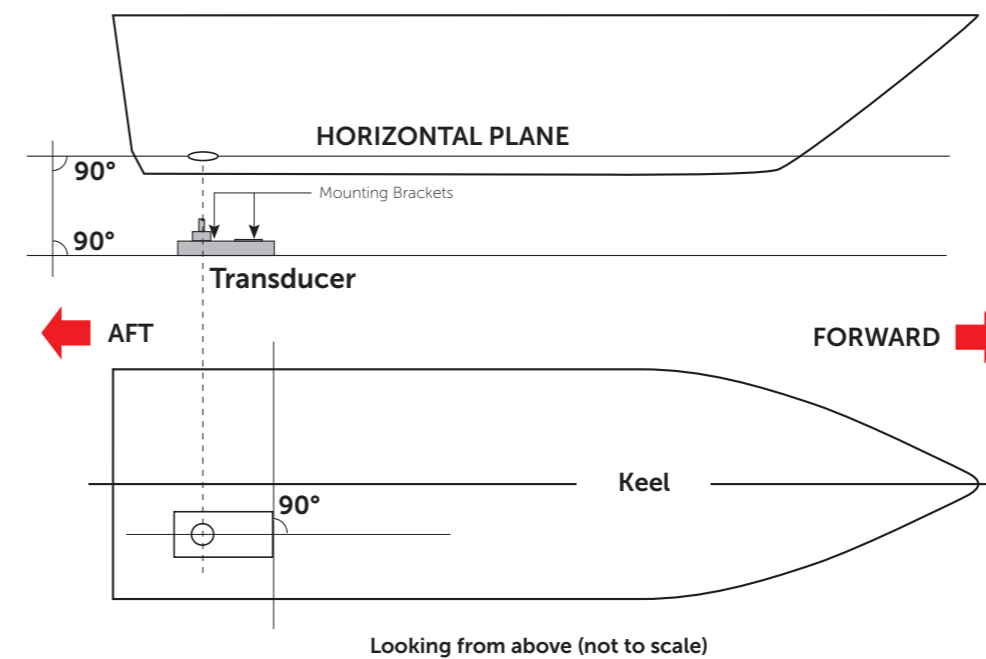

Figure 5. Positioning the Transducer on the Vessel Hull



**CAUTION:** The above mounting example is provided as a guide. WASSP Ltd. recommend that a reputable boat builder is used to install the transducer to prevent damage to the vessel's hull.

### 3.2. POLE MOUNTING

The transducer can be used with a temporary mounting assembly. The assembly would typically incorporate transducer, and a position and motion sensor, and be deployed on a rigid mount over the side or the stern of the vessel such that it can be raised / lowered when required.

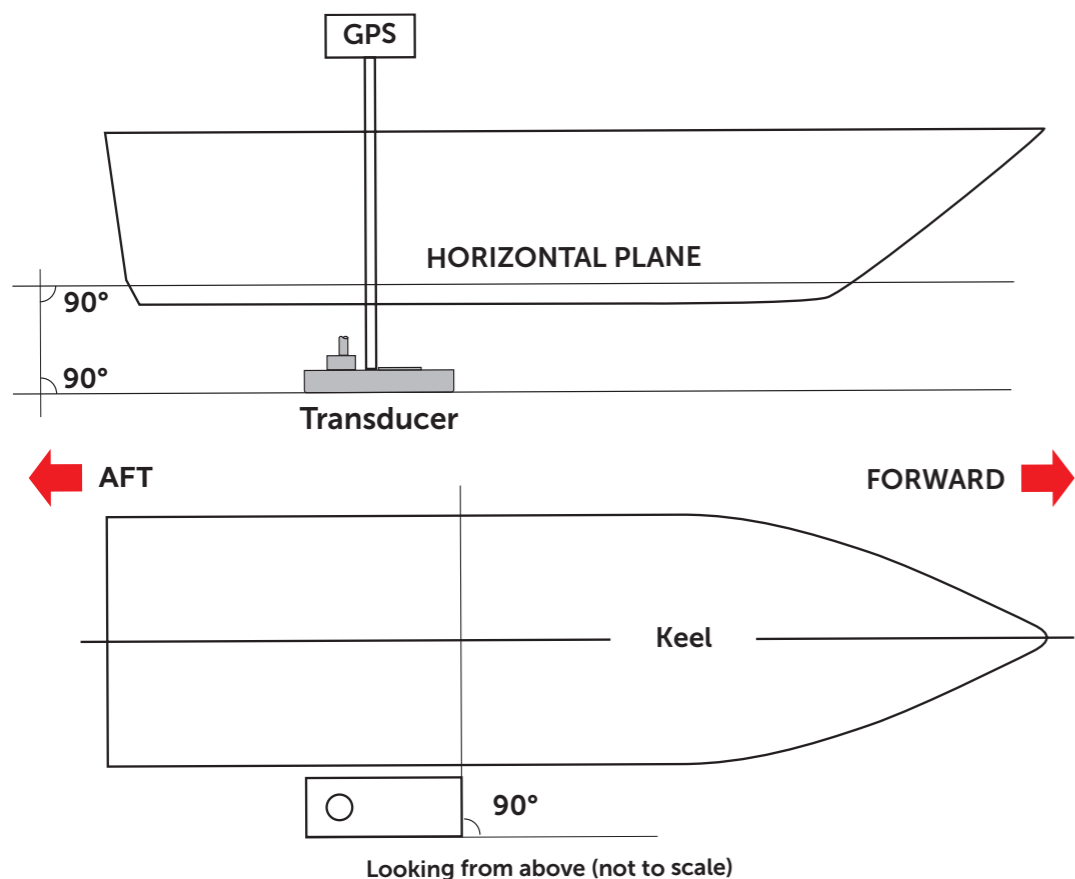

Figure 6. Pole Transducer Mounting



**CAUTION:** The above mounting example is provided as a guide. WASSP Ltd. recommend that a reputable boat builder is used to fabricate the pole mount assembly.

Any flex in the pole mount during operation will introduce errors.

### 4 HULL MOUNTING CONSIDERATIONS

The transducer is mounted on the hull below the water line, normally using a permanent sea chest. The transducer must be mounted so that it is aligned with the fore-aft axis of the vessel. It must also be mounted so that the flat underside of the transducer is as close to horizontal as possible.

If the vessel has a keel, the transducer can be mounted somewhere along the length of it. If it is mounted on the hull, it should be far enough away from the keel so that the keel will not be detected within the 120° WASSP beam pattern. *Figure 4 on page 9* shows a sea chest type through-hull mounting designed specifically for a fast moving, alloy hull crayfish boat.

The performance of the system is directly related to the mounting location of the transducer, especially for high-speed cruising. The installation should be planned in advance, keeping in mind the fixed cable length of your transducer (5m / 10m / 20m) and the following factors:

- » Air bubbles and turbulence caused by movement of the vessel seriously degrade the sounding capability of the transducer. The transducer should be located in a position with the smoothest water flow.
- » The transducer should not be mounted close to propellers because noise from propellers can adversely affect the performance of the transducer.
- » Mount the transducer inboard of lifting strakes as these create acoustic noise.
- » The transducer must always remain submerged, even when the boat is rolling, pitching or planing at high speed.
- » A practical choice would be somewhere between a 1/3 and a 1/2 of the boat's length from the bow. For planing hulls, a practical location is generally towards the rear of the vessel, to ensure that the transducer is always submerged, regardless of the planing angle.
- » Do not mount another transducer near the WASSP transducer as it will cause interference

#### Planing hulls

On planing hulls the transducer needs to be mounted in or on the aft part of the hull, which stays in the water when the vessel is on the plane.

The transducer can be mounted either in a streamlined housing or blister on the hull or inside the hull in a specially prepared cofferdam, with the transducer face flush with the hull and faired to the hull shape.

It is important that the part of the hull in front of the transducer is smooth and has no hull penetrations or attachments of any kind.

#### Displacement hulls

A practical choice is somewhere in the area between a 1/3 and a 1/2 of the vessel's length, from the bow. The transducer should be mounted in a housing or blister attached to the hull.

The disturbed aerated water tends to be in a layer against the hull, it's thickness varies by vessel's speed and sea conditions. Therefore the deeper the housing is, i.e. the further the transducer is away from the hull, the better the equipment will perform. Also on V-shaped hulls the housing should be mounted against or close to the keel, again to get deeper and away from aeration and turbulence. The 120 WASSP beam pattern must be kept in mind when mounting the transducer. No part of the keel or hull should protrude into this pattern.

### Larger displacement hulls with bow thruster

The best location on these vessels is in or against the keel, forward of a line just aft of the thruster cavity. Locations further aft are becoming heavily affected by aeration when the vessel pitches and air exhausts out of the thruster tunnel on the downward movement of the bow. This air creates havoc with the performance of any transducers further aft on the hull. "Figure 7. Transducer mounting locations for larger displacement hulls" suggest mounting locations for these types of vessels.

In these installations, the strength of the mounting becomes very important, as the transducer can be out of the water when the vessel pitches. Re-entry into the water exerts large forces on the transducer face and the mounting structure.

See "5.1. 160kHz Transducer Mounting" on page 13 and "5.2. 80kHz Transducer Mounting Assembly" on page 15 for mounting diagrams and instructions. These steps must be carried out accurately and completely.

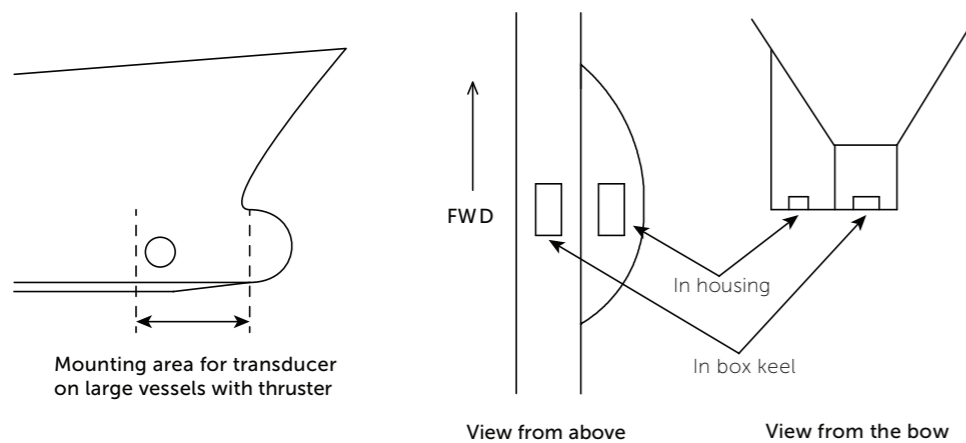

Figure 7. Transducer mounting locations for larger displacement hulls



**CAUTION:** Please see "5 Mounting Assembly" on page 13. In particular pay attention to the torque tension of the mounting nuts and the requirement to fill any gaps that exist between the transducer body and the retaining with epoxy.



A non-solvent based anti-fouling must be applied to the transducer face

## 5 MOUNTING ASSEMBLY

### 5.1. 160KHZ TRANSDUCER MOUNTING

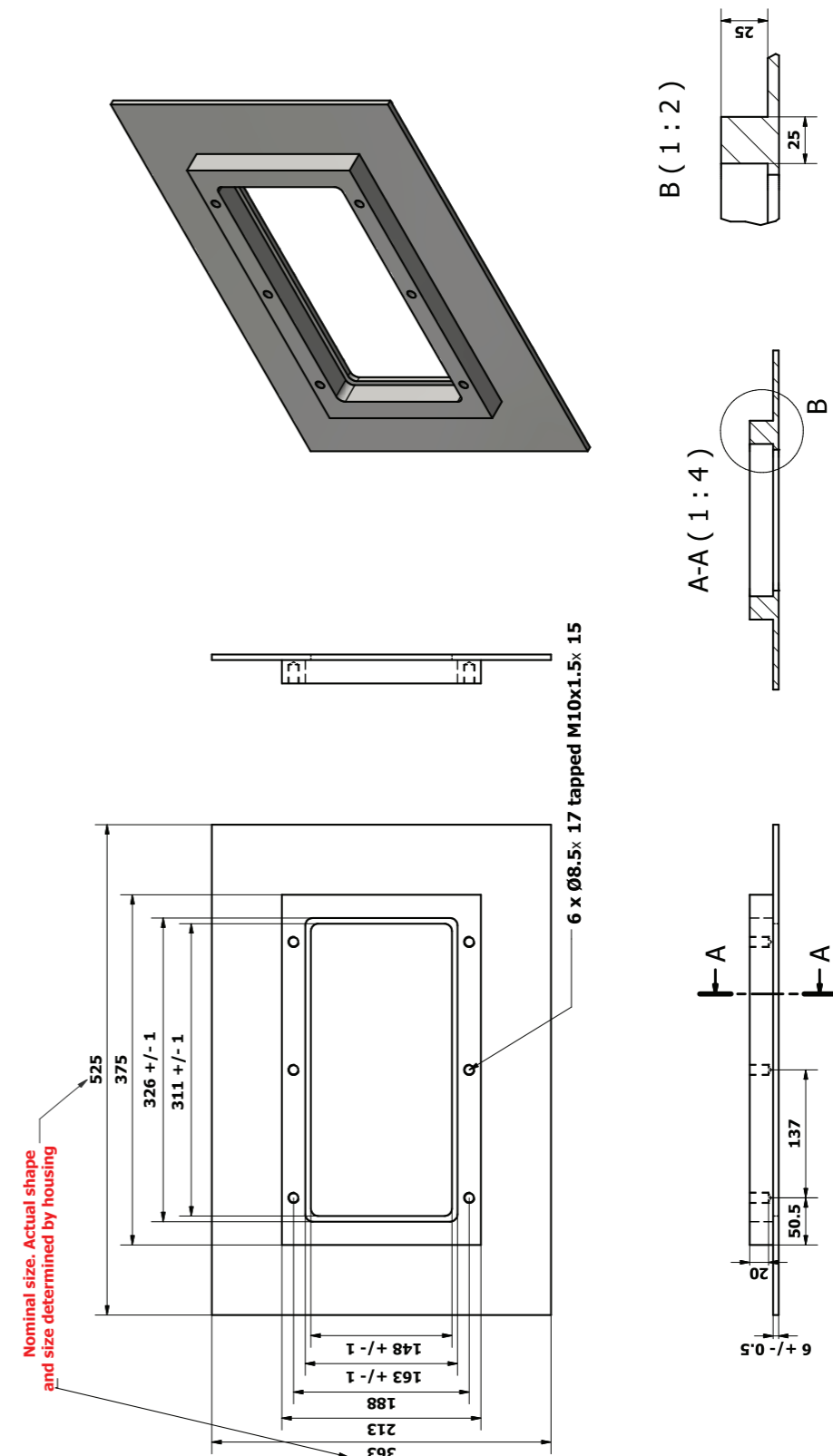

ALL MEASUREMENTS ARE NOMINAL. CHECK THE ACTUAL MEASUREMENTS OF THE TRANSDUCER.

PARTS LIST

ITEM	QTY	PART NUMBER	DESCRIPTION
1	3	Angle iron clamp	40x40x5 mm mild steel
2	1	Mounting plate	Mild steel
3	1	Transducer	WSP-501-160
4	6	Threaded end	M10x1.5 120 mm
5	12	M10 nut	

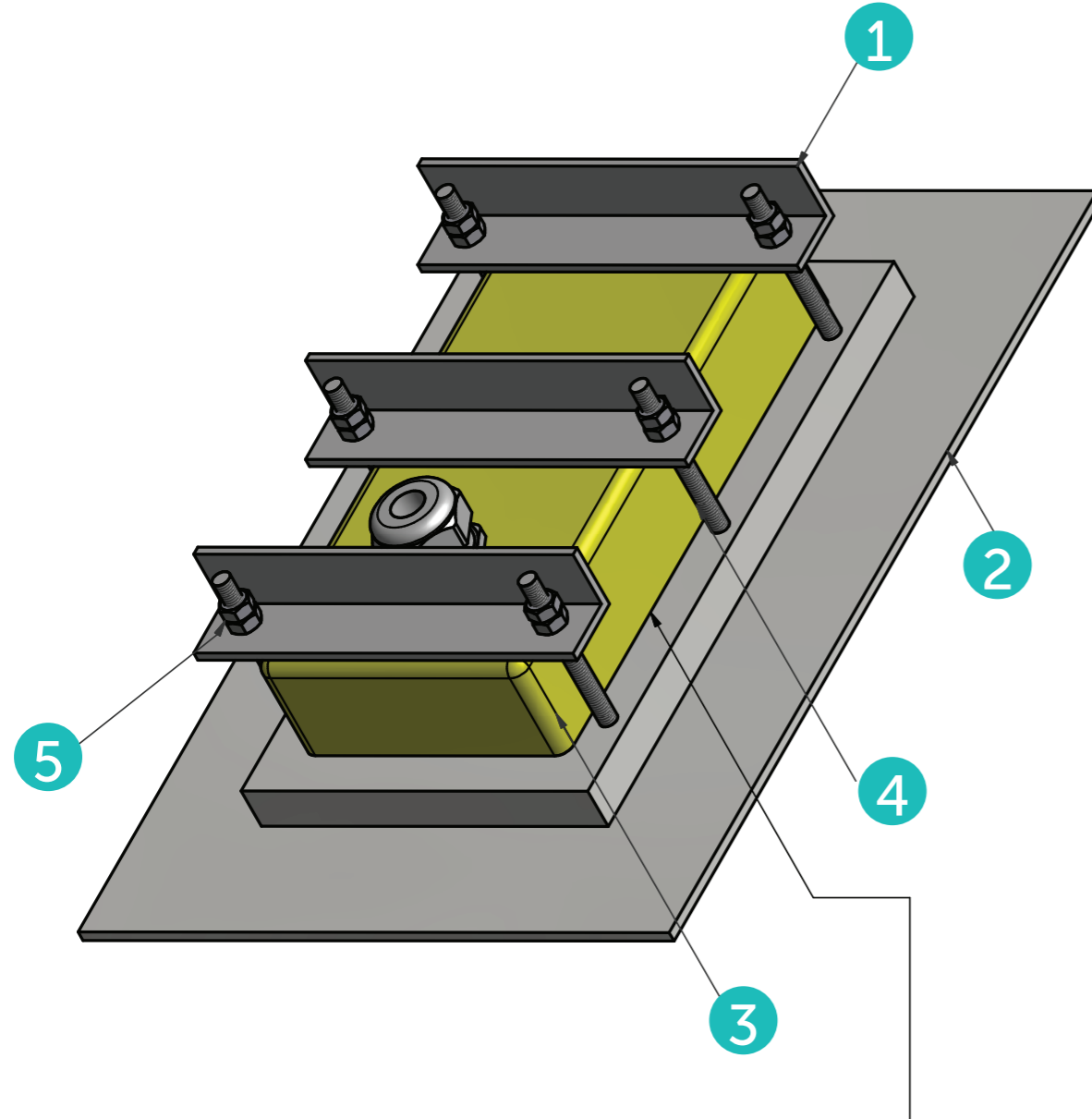

**FILL GAP, AROUND WHOLE CIRCUMFERENCE OF TRANSDUCER, WITH 24 HR CURE MARINE EPOXY**

5.2. 80KHZ TRANSDUCER MOUNTING ASSEMBLY

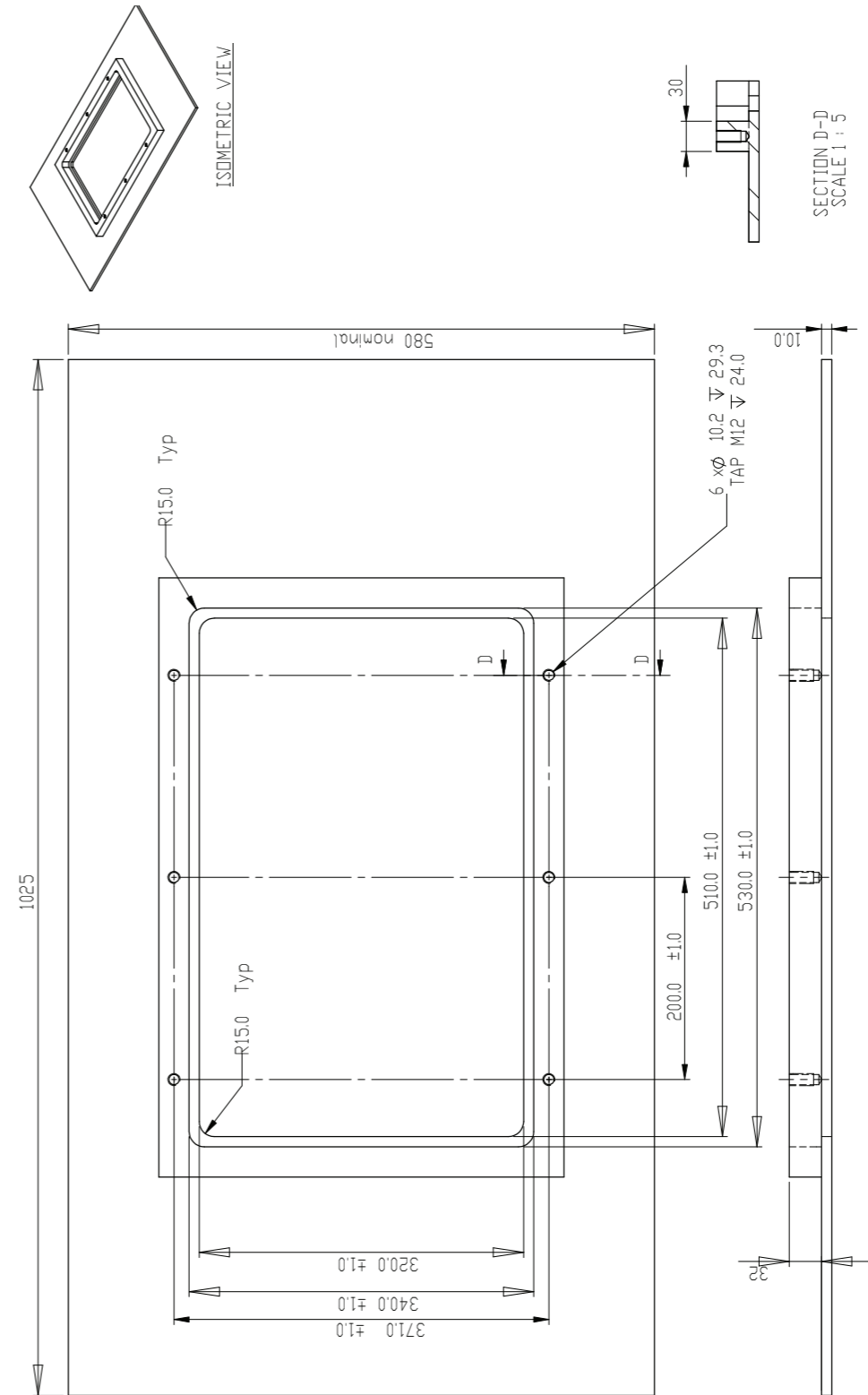



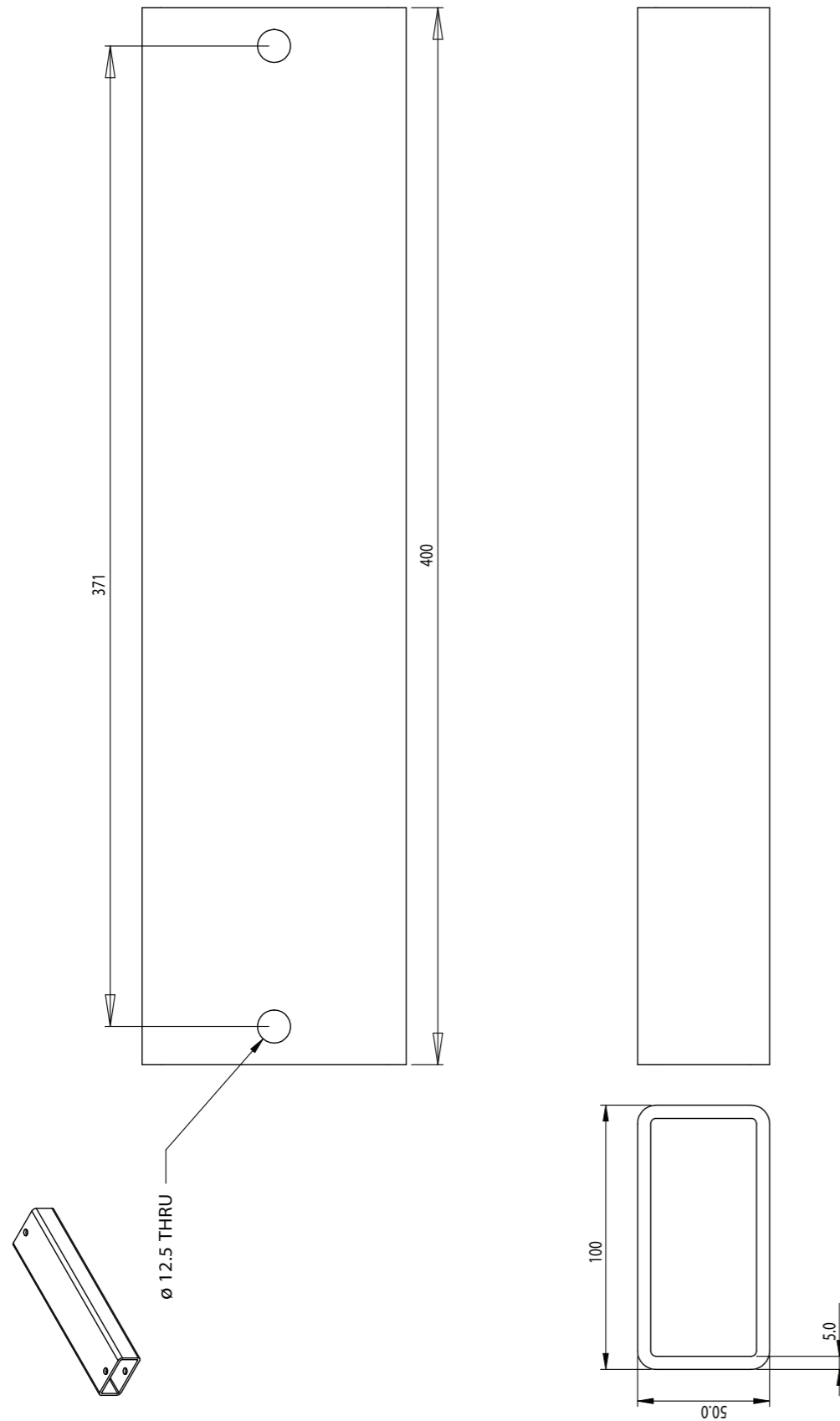

Tighten the nuts indicated by "4" to a torque of 1.5-2Nm.

If any gaps exist between the transducer body "6" and the mounting frame "1" they will need to be filled by a water proof 24hr cure epoxy.

All measurements are nominal. Check measurement of the actual transducer.

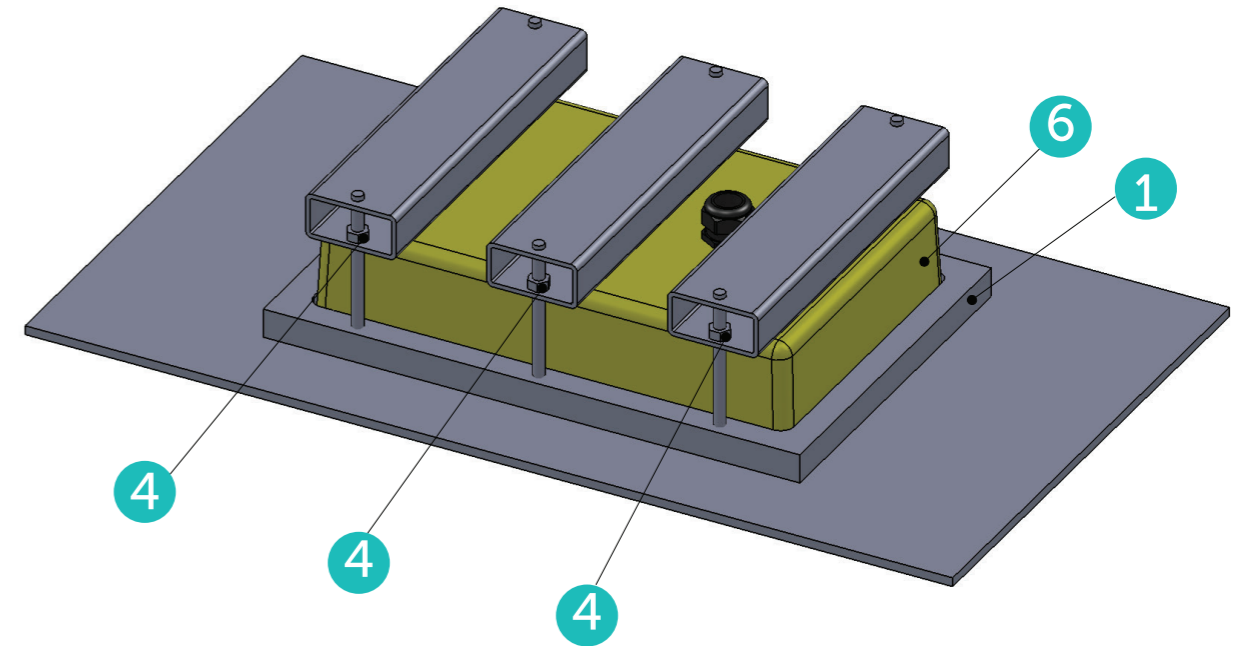

### 5.3. WIDEBAND FAIRING TRANSDUCER 90-190KHZ MOUNTING

#### Part List (WSP-002-133 & WSP-002-134)

ITEM	QTY	PART	Description
1	1	Fairing Block	
2	2	Threaded rod	M12
3	6	Washer	M12
4	6	Nut	M12
5	2	Locking Nut	M12 (Nyloc)

Not included:

- Mounting tools
- Marine sealant

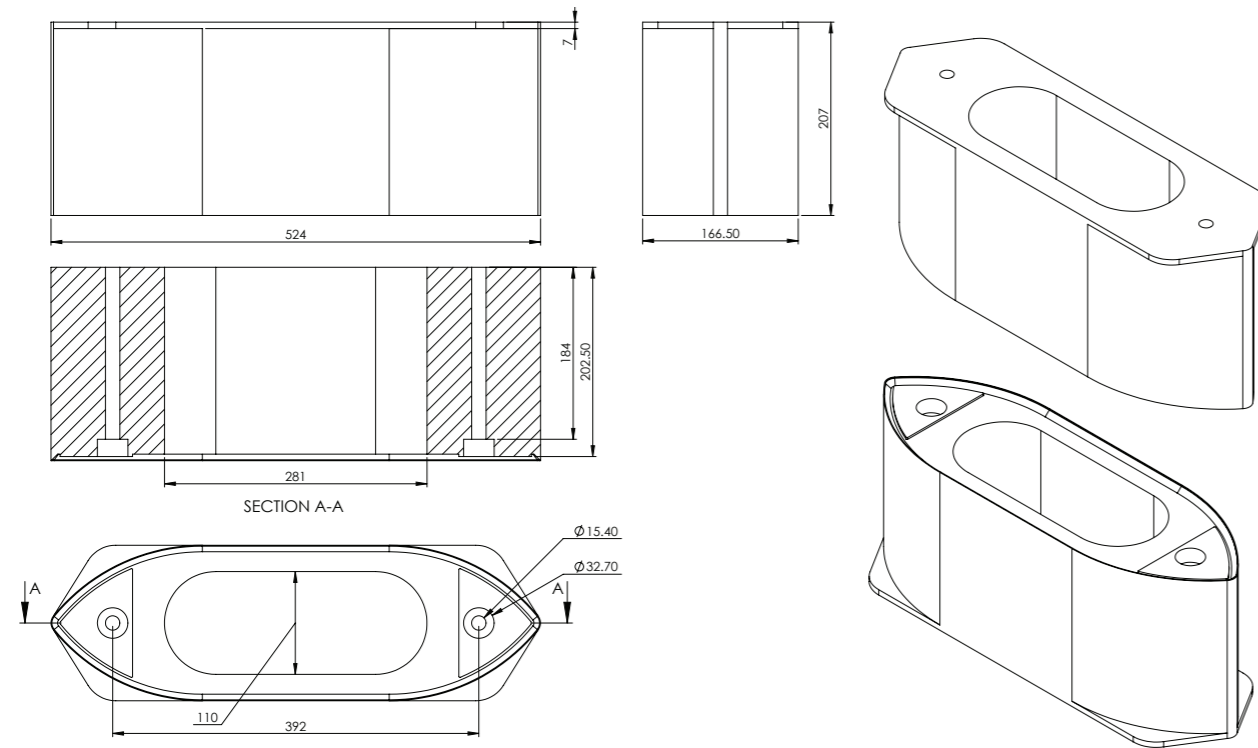

### 6 WASSP WIDEBAND FAIRING TRANSDUCER 90-190KHZ INSTALLATION

Follow the following guidelines:

- » DO NOT use the WASSP Wideband Fairing Transducer 90-190kHz for boats exceeding 40kn. Instead, use the WASSP 160kHz Transducer.
- » A WASSP gland must be used to lead the WASSP transducer cable through the hull.
- » Mount the front of the transducer facing forward. (the transducer can be mounted back to front if necessary. Enable the setting swap array in the corrections page of the WASSP web pages)
- » The fairing can be cut up to a 30 degrees deadrise.
- » The Locking nuts must not exceed 30N-m torque when tightening the nuts.
- » Ensure the threaded rods are isolated from the hull when installing on an aluminium hull to prevent electrolysis.
- » A coffer dam must be installed to ensure hull integrity is maintained in the event of forces in excess of 40kn water pressure (such as a collision).
- » Consider a cofferdam to ensure the structure of the hull in case of unexpected events like collision.

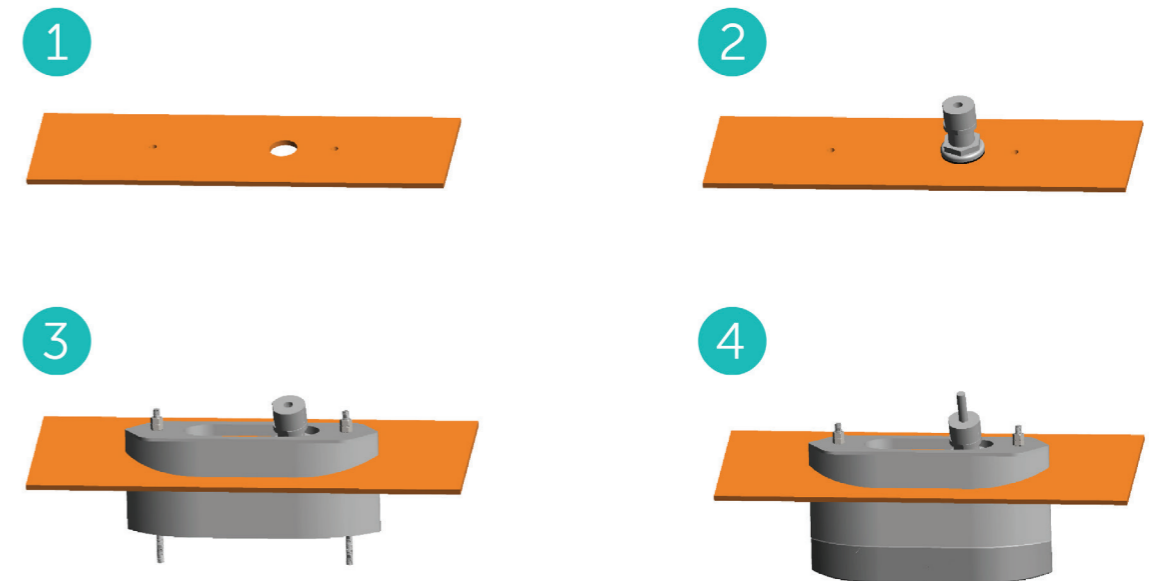

### 6.1. MEASURE AND PREPARATION

1. Measure the deadrise of the hull at the transducer mounting location.
2. Cut the fairing using the measured deadrise angle. The cutting guide on the fairing can be used to guide the fairing over a bandsaw table.
3. Hold the fairing against the outside of the hull to make sure there is no spacing between the fairing and the hull. Gaps could result in bending and cracking the fairing.
4. Hold the backing block against inside of the hull to make sure there is no spacing between the backing block and the hull.
5. Mark the locations for the 2 threaded rods while holding the fairing or the backing block.
6. Mark the cavity for cable gland area.
7. In the cavity for cable gland area mark the position for the gland. Make sure to allow at least 4cm distance between the centre of the WASSP gland and the outside of the gland cavity area.

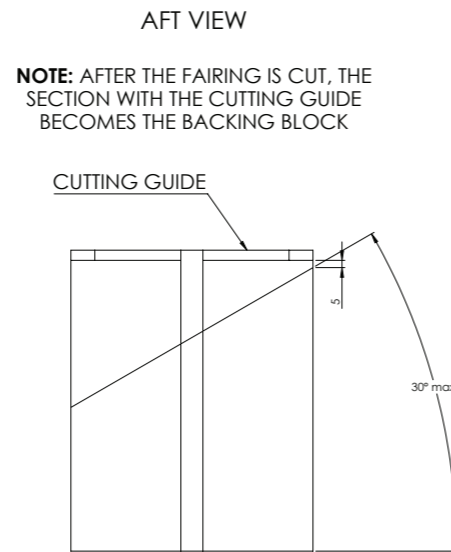

Consider the space available in the cavity for cable gland area of the backing block when using the WASSP Wideband Fairing Transducer 90-190kHz with fairing. Additional space can be created by creating a gland relief cut-out in the backing block for additional space to fit the gland or a relief for a suit bulk heads.

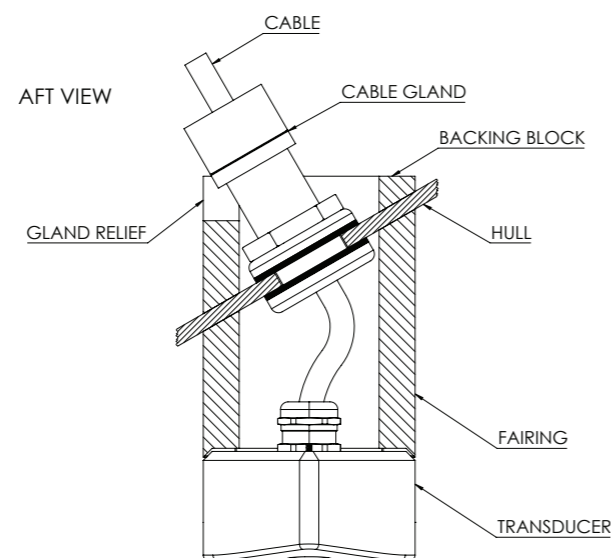
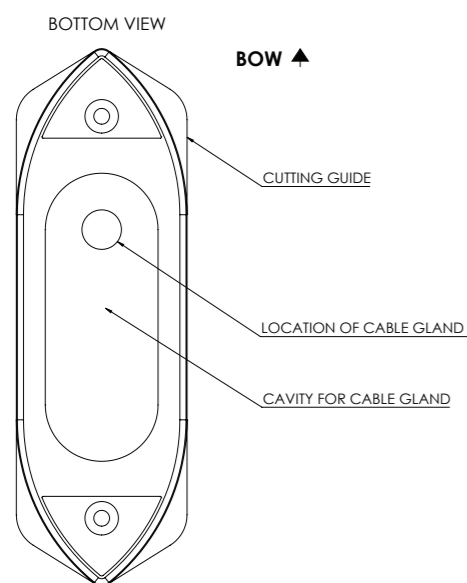

### 6.2. MOUNTING THE FAIRING

Drilling holes and final check before installation:

1. Hold the fairing against the hull and check the following
  - The location of the threaded rod hole marks is correct (marked in step 5 of "Measure and Preparation")
  - The location of the gland hole is at least 5cm away from the edge of the gland cavity area.
  - The distance between the two threaded rod holes is 392mm.
2. Drill the holes for the threaded rods.
3. Place a nut 82mm above the transducer end of the threaded rod and add a washer at the fairing end. 82mm of thread is required to hold the transducer (see 6.4)
4. Hold the fairing against the hull and push the long end of the threaded rods up through the fairing and hull all the way to the washer and nut.
5. Place the backing block over the gland.
6. Place a washer and two nuts on the threaded rods inside the boat to secure the backing block.
7. Take the fairing and backing block off.



Mount the WASSP gland step 1 till 6 from chapter 7.2

### 6.3. FAIRING INSTALLATION

1. Apply a thick layer of marine sealant to:
  - a. The surface of the fairing that will be in contact with the hull.
  - b. The surface of the backing block that will be in contact with the hull.
  - c. The threaded rods
2. Again, place a washer and nut back above 82mm on the threaded rods.
3. Hold the fairing against the hull and push long end of the threaded rods through the fairing and hull
4. Place the backing block over the gland.
5. Place a washer and two nuts on the threaded rods inside the boat to secure the backing block not exceeding 30N-m. (make sure the length of the threaded rod under the fairing is 82mm to the nut).

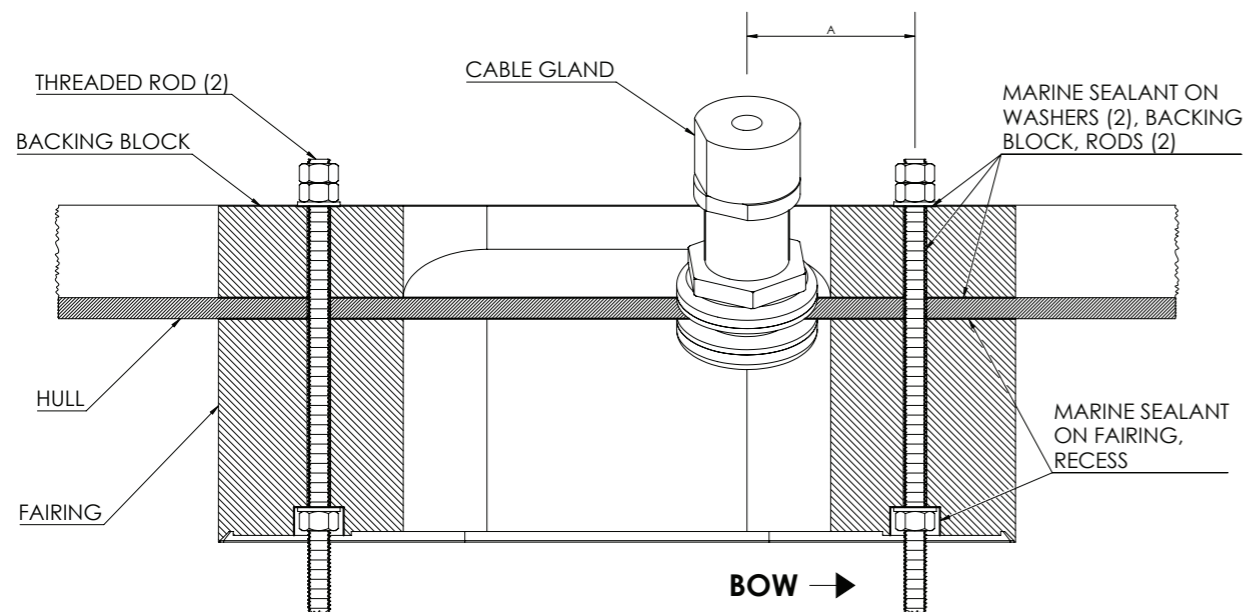

### 6.4. TRANSDUCER INSTALLATION

1. Apply a thick layer of marine sealant to the TOP of the transducer that will contact the fairing.
2. Guide the transducer cable trough the WASSP gland. Before guiding the transducer into place, apply marine sealant between the gland pipe and the transducer cable and push the sealant into the gap.
3. Guide the transducer in its position against the fairing. Make sure the side of the Wideband Fairing Transducer 90-190kHz cable is forward.



4. Apply a washer and nylon locking nut to bolt threaded rods not exceeding 30N-m. Make sure that the threaded rod protrudes at least 3mm from the nut but does not protrude the transducer face. This is so that it will not cause aeration when sealed off.
5. Fill the bolt holes on the face of the transducer ensuring that they are sealed and flush, consider the product(s) used as it will need to be removed for the transducer to be removed.
6. Remove any excess marine sealant when marine sealant has dried up.
7. Apply a non solvent based anti-fouling that covers the transducer face, housing and fairing.

Finish locking the WASSP gland from step 8 onwards in chapter 7.2

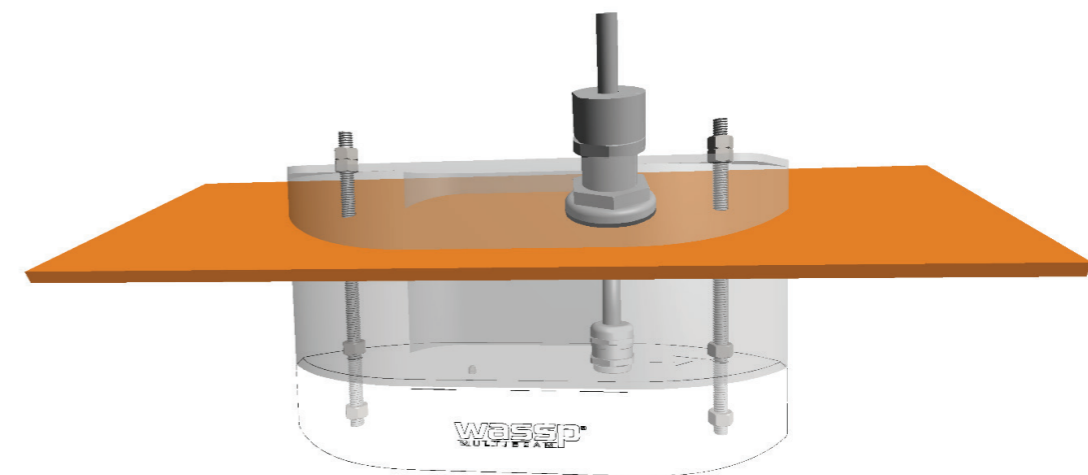

## 7 CABLE INSTALLATION

### 7.1. GLAND ASSEMBLY

"Figure 8. Alloy / Plastic Gland Assembly Outline and Dimensions" shows the physical dimensions of the WASSP Ltd. supplied alloy / plastic gland assembly. The steel gland is different to below.

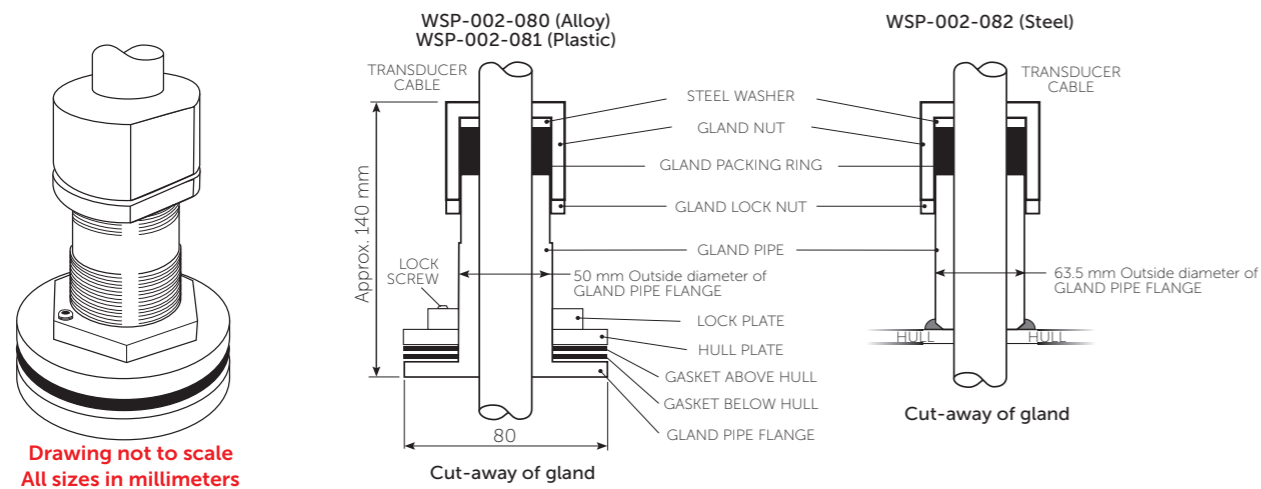

Figure 8. Alloy / Plastic Gland Assembly Outline and Dimensions

### 7.2. MOUNTING THE CABLE GLAND

Depending on the boat the transducer to be installed and the type of gland being used, there are various ways of mounting the cable gland to the hull. Adapt the following procedures to suit your installation while taking the following into consideration:

- » Use personal protection gear such as safety goggles and dust mask during installation. Make sure the work area is well ventilated when using sealant and cleaning solvent.
- » Always use a good quality marine sealant to seal across the areas that can leak (See "Figure 9. Mounting the Gland Assembly" on page 25). Before applying marine sealant to the parts, make sure they are free from oil and water. Use general cleaning solvent to remove oil or grease if needed.
- » Make sure all the gland parts are installed and are installed at the correct order.
- » When installing the gland packing ring, apply soapy water to the cable to assist installation if necessary. Clean off all the soapy water and dry all the parts before applying sealant.

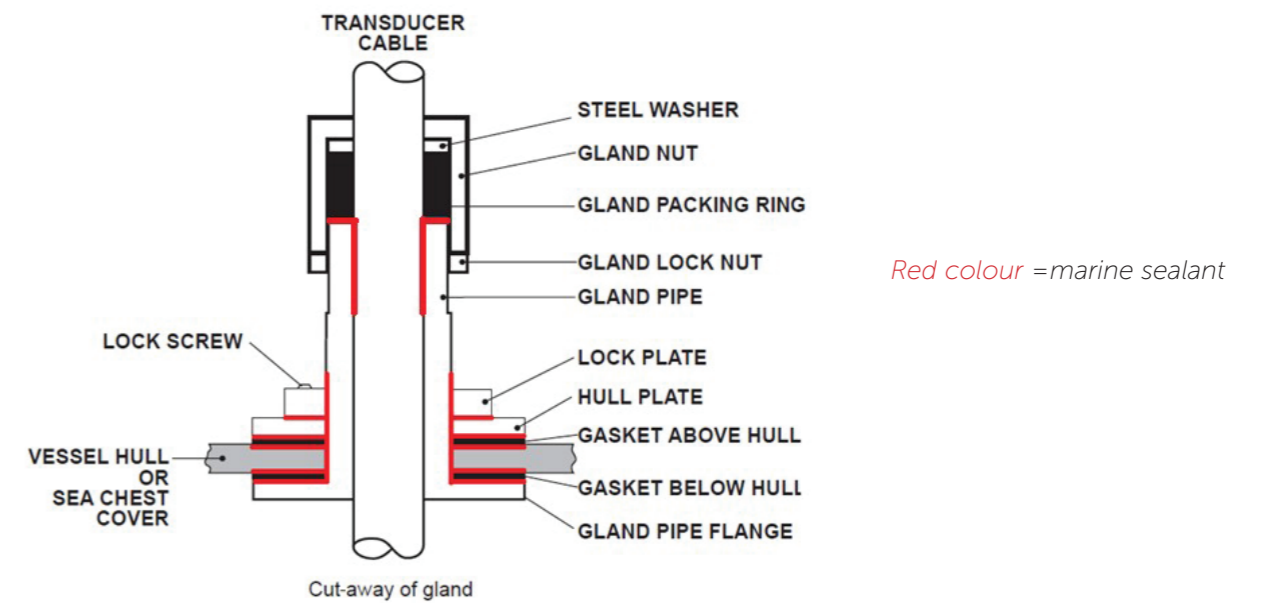

Figure 9. Mounting the Gland Assembly

<b>1</b>	Apply marine sealant to the upper side of the gland pipe flange.
<b>2</b>	Place the bottom gasket over the gland pipe. Apply marine sealant to the gasket.
<b>3</b>	Push the gland pipe into the hole in the vessel hull.
<b>4</b>	Apply marine sealant to both sides of the top gasket. Place the top gasket over the gland pipe.
<b>5</b>	Place the hull plate over the gland pipe and onto the top gasket.
<b>6</b>	Apply marine sealant around the gap between the hull plate and the gland pipe. Screw the lock plate onto the gland pipe using a spanner. Tighten the lock plate until a good joint is achieved. Clean excess marine sealant. Lock the lock plate lock screw using an allen key.
<b>7</b>	Feed the transducer cable through the gland.
<b>8</b>	Apply marine sealant between the gland pipe and the transducer cable. Push the sealant to the gap.
<b>9</b>	Install the gland packing ring.
<b>10</b>	Install the steel washer.

- 11** Install the gland lock nut.
- 12** Install the gland nut.
- 13** Tighten the gland nut by hand until the components are aligned. Use a spanner to further tighten the nut with light arm force for around 1 to 1.5 turn until an increase in resistance is felt. After that, further tighten the nut by 2 turns or tighten to 30Nm. Tighten the lock nut against the gland nut. Double check the tightening by measuring the length from the nut bottom edge to the ending edge of the nut thread on the gland body (length A) for aluminium and acetal glands (Figure 10). With steel glands, check the length from the nut bottom edge to the flat surface on the gland base (length B in Figure 11). Length A needs to be less than 20mm. Length B needs to be less than 14mm.



Figure 10. Gland nut travel measurement point for acetal and aluminium glands



Figure 11. Gland nut travel measurement point for steel glands

- 14** After the gland nut and lock nut are tightened and the marine sealant is cured, place the boat in water and carefully check the gland for leaks. If leak is observed, tighten the gland nut further by 0.25-0.5 turn. If leak continues or leak is found at the gland base, uninstall the gland, check the conditions of all the parts and repeat the installation procedures immediately. Recheck the gland for leak 6 hours after the boat is in water.

### 7.3. TRANSDUCER CABLE

The transducer cable consists of seven CAT-5 cables and one screened pair for the transmit connection.

To fit the RJ-45 connectors and cable through the gland, no special preparation is required.

The WASSP transceiver cable end has the RJ-45 connectors fitted with "staggered" cable lengths. This allows each RJ-45 connector and its associated cable to be fed through the gland fitting easily.

Commencing with the black RJ-45 cable and black transmit cable, feed each cable in turn through the gland, finishing off with the grey RJ-45 connector and cable.

Complete fitting and tightening the gland as shown in "Figure 8. Mounting the Gland Assembly" on page 25.



**NOTE:** Colour code for transmit cable conductors: White, Black and Green.



**CAUTION:** DO NOT STRAIN THE TRANSDUCER CABLE!

Forcing the cable to bend, twist, or stretch beyond its means will damage the transducer and impair performance.

Once the transducer has been installed, ensure that the transducer cable is not under tension. Use cable ties (or similar) to secure the cable as necessary.



Figure 12. Gland Assembly - Cable Connectors

### 7.3.1. Replacing / Repairing an RJ-45 Connector

If one or more of the RJ-45 connectors gets damaged during the installation process, the connector can be easily replaced. Wiring details and colour codes used are shown below.



The CAT5E cables used in the transducer cable follow standard CAT5 colour codes but the RJ-45 plug wiring is specific to the WASSP transceiver and does NOT conform to T568A or B:

RJ-45 Plug Pin Number	CAT 5 conductor colour
1	Orange
2	Orange / White
3	Green
4	Green / White
5	Blue
6	Blue / White
7	Brown
8	Brown / White
Case	Screen / drain wire (solder)

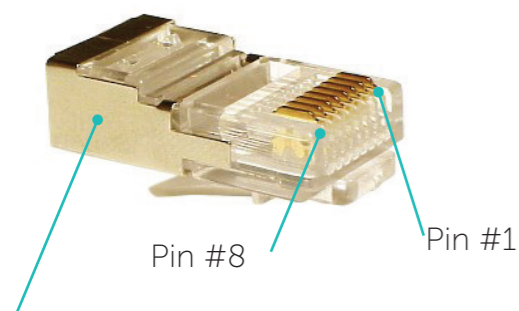

The screen / drain wire should be soldered onto the side of the RJ-45 connector. Scratch the side of the connector with something sharp before soldering to assist with the join.

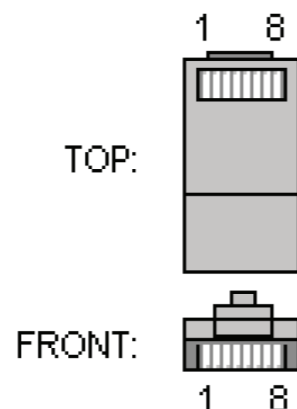

## 8 CABLE CONNECTION TO DRX

Transducer Receive Channels should be discharged prior to connection to the DRX. This should be done **every time** the DRX is connected to the transducer.

To discharge the Transducer:

1. Peel off the cover label on DRX front panel, remove the black blanking plastic on the X/TX port.
2. Plug each of the 7 Transducer Receive Cables into X/TX socket in turn.

Once discharge has been performed on every cable connect each cable to the correct receive port on the DRX. For further information on connection to the DRX see the DRX Installation Manual

If this label shown in Figure 12 is not present on delivery, then discharge is not available on this DRX. In this event you may have been supplied with an external discharge module.

If you plan to connect any transducer to a DRX and your unit does not have a built-in discharge port then we recommend you request an external discharge module to prevent damage to your DRX.

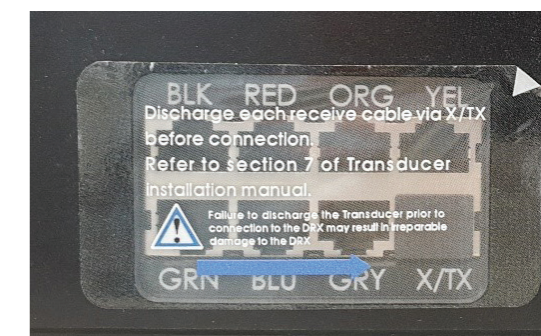

Figure 13. DRX with the Transducer Receive Discharge cover label instruction



**CAUTION:** Failure to discharge the transducer prior to connection to the DRX may result in irreparable damage to the DRX.

If you have an external discharge module follow the same procedure as above but use the external discharge module rather than the X/TX socket to discharge the individual Transducer Receive Channels each time you wish to connect the transducer to the DRX. For the 80kHz Transducer, it is important that the receive channels are discharged prior to connection to the DRX.



Figure 14. Ceramic Discharge Module

To discharge the transducer use the supplied Ceramic Discharge Module (shipped with WASSP 80kHz Transducers).



Figure 15. Discharging Transducer Channels

Connect each of the 7 Transducer Receive Cables in turn to the RJ45 socket on the Discharge Module. Connection will result in the receive ceramics discharging through the module.

This procedure should be carried out no more than 10 minutes prior to connecting cables to the DRX.

## 9 TECHNICAL SPECIFICATION

The table below gives nominal mechanical and performance specifications for WASSP Transducers.

	160KHZ TRANSDUCER	Wideband Firing Transducer 90-190kHz	80KHZ TRANSDUCER
<b>Mechanical</b>			
Weight	12 (10m cable)	14.5 (10m cable)	29 (20m cable)
Height [mm]	94	85.5	130
Width [mm]	163	166.5	336
Length [mm]	326	524	527
<b>Performance</b>			
Swath Width	120°	120°	120°
Beamwidth Fore Aft	3.2°	3.2°	3.2°
Beamwidth Port Starboard	4.4°	4.4°	4.4°
TVR	159 dB	159 dB	159 dB
RVR	-194 dB	-194 dB	-194 dB
<b>Cable Gland Assembly</b>			
Static Pressure	6bar*	6bar*	6bar*

\*Require installation as per instructions in manual

Table 1. Technical Specification

## 10 PRODUCT REGISTRATION, SUPPORT AND RESOURCES

### TECHNICAL SUPPORT

If you require maintenance and/or repair contact your local dealer. A list of WASSP dealers and distributors is available at [wassp.com](http://wassp.com).

DRX technical support is available directly through:

- » Email: [support@wassp.com](mailto:support@wassp.com)
- » Online: <http://wassp.com/support/> and click on 'Request Support'

### LATEST RESOURCES

- » For the latest version of manuals: <http://wassp.com/manuals/>
- » For software updates and release notes: <http://wassp.com/software-updates/>
- » For system drawings, mechanical drawings and declarations of conformity: <http://wassp.com/dealer-resource>



