

Installation Manual

MULTI FUNCTION DISPLAY

Model TZT9F

SAFETY INSTRUCTIONS	i
SYSTEM CONFIGURATION	ii
EQUIPMENT LISTS.....	iii
1. MOUNTING.....	1-1
1.1 Installation of Multi Function Display.....	1-1
1.2 Installation of Transducers.....	1-7
2. WIRING.....	2-1
2.1 Interface Connections (Rear of Unit)	2-1
2.2 Composite Connector	2-2
2.3 How to Secure and Waterproof Connections.....	2-2
2.4 Power Cable	2-3
2.5 MULTI Cable.....	2-3
2.6 DRS Radar Sensor Connections	2-4
2.7 Network Connector	2-4
2.8 CAN bus (NMEA2000 Connector)	2-4
2.9 Transducer (Option).....	2-9
2.10 Example TZT9F System Configurations	2-9
3. HOW TO SET UP THE EQUIPMENT	3-1
3.1 How to Set Time Zone, Time Format and Language.....	3-4
3.2 How to Set Units of Measurement	3-6
3.3 Initial Setup	3-7
3.4 How to Set Up the Radar	3-13
3.5 How to Set Up the Sounder	3-16
3.6 Wireless LAN Setting	3-20
3.7 Ferry Mode.....	3-22
PACKING LISTS	A-1
OUTLINE DRAWINGS	D-1
INTERCONNECTION DIAGRAM	S-1

**FURUNO ELECTRIC CO., LTD.**www.furuno.com

ECF

(Elemental Chlorine Free)

The paper used in this manual
is elemental chlorine free.

FURUNO ELECTRIC CO., LTD.

9-52 Ashihara-cho,
Nishinomiya, 662-8580, JAPAN

• FURUNO Authorized Distributor/Dealer

All rights reserved. Printed in Japan

Pub. No. IME-45090-B

(GREG) TZT9F

A : OCT. 2020

B : MAR. 10, 2021



0 0 0 1 9 7 9 0 7 1 1



SAFETY INSTRUCTIONS



WARNING

Indicates a potentially hazardous situation which, if not avoided, could result in death or serious injury.



CAUTION

Indicates a potentially hazardous situation which, if not avoided, may result in minor or moderate injury.

(Examples of symbols)



Warning, Caution



Prohibitive Action



Mandatory Action



WARNING



ELECTRICAL SHOCK HAZARD
Do not open the equipment unless totally familiar with electrical circuits.

Only qualified personnel should work inside the equipment.



Turn off the power at the switchboard before beginning the installation.

Fire or electrical shock can result if the power is left on.



Be sure that the power supply is compatible with the voltage rating of the equipment.

Connection of an incorrect power supply can cause fire or damage the equipment.



If your vessel is configured with an autopilot system, install an autopilot control unit (or emergency autopilot stop button) at each helm station, to allow you to disable the autopilot in an emergency.

If the autopilot cannot be disabled, accidents may result.



CAUTION



Ground the equipment to prevent electrical shock and mutual interference.



Use the proper fuse.

Use of an incorrect fuse may damage the equipment.



The front panel is made of glass. Handle it with care.

Injury can result if the glass breaks.



Observe the following compass safe distances to prevent interference to a magnetic compass:

Model	Standard compass	Steering compass
TZT9F	0.40 m	0.30 m

SYSTEM CONFIGURATION

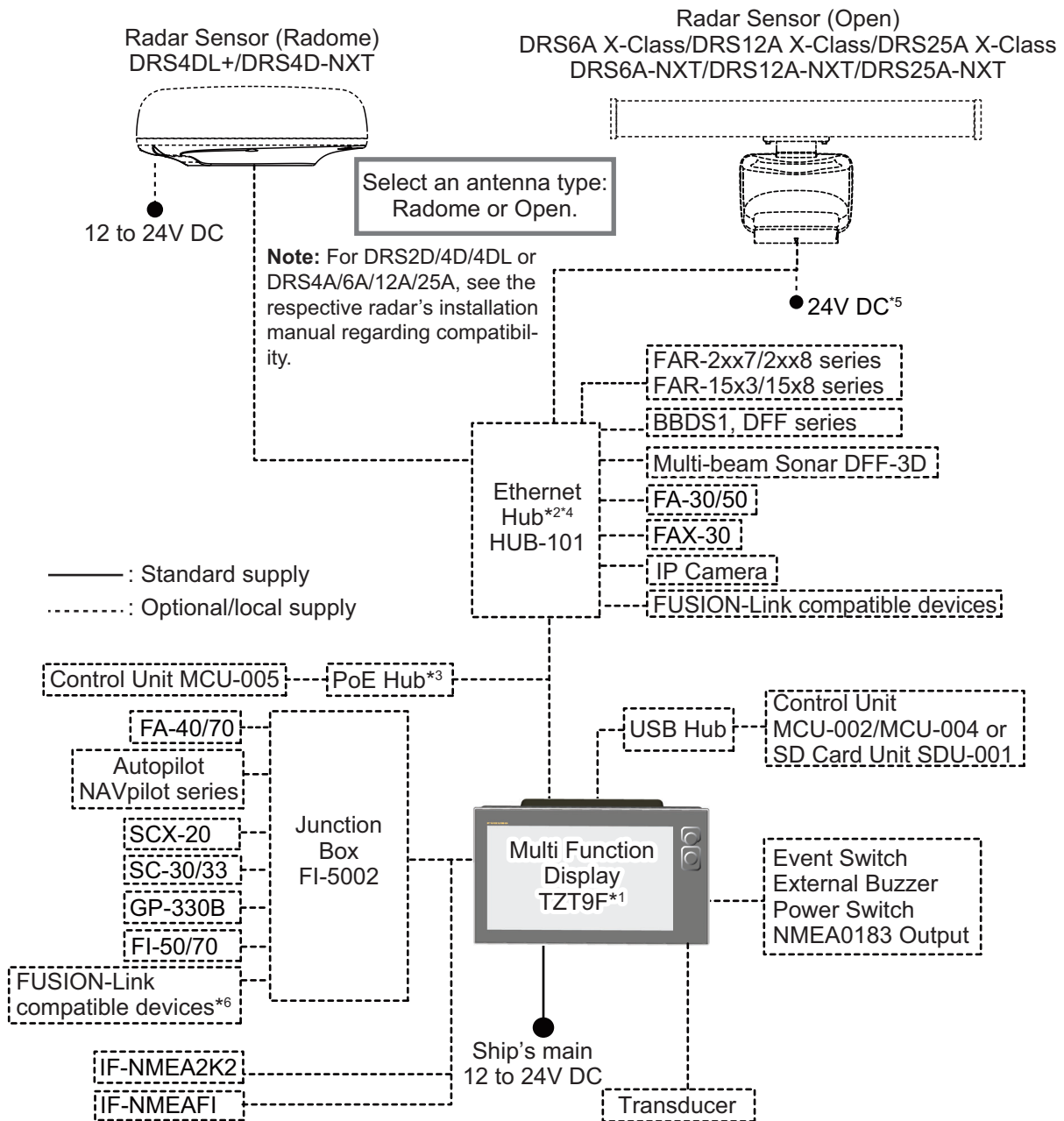

Category of units

Antenna unit: Exposed to the weather.
 Other units: Protected from the weather.

- *1: This unit has a built-in fish finder as standard.
- *2: A maximum of 6 units of NavNet TZtouch2/3 can be connected. NavNet TZouch2 requires software version 7. For configurations with TZT2BB included, a maximum of 4 NavNet TZtouch2/3 units can be connected. NavNet TZtouch cannot be connected.
- *3: Use a commercially available PoE hub. "GS108PE" of NETGEAR has tested compatible. The basic functions of the hub were verified, however the compatibility of all functions were not checked. FURUNO cannot guarantee proper operation.
- *4: FURUNO networks allow a maximum of three HUB-101 units on the same network.
- *5: DRS6A-NXT is rated for either 12 V or 24 V DC power supply.
- *6: The connected FUSION-Link device must also have CAN bus connectivity.

EQUIPMENT LISTS

Standard supply

Name	Type	Code No.	Qty	Remarks
Multi Function Display	TZT9F	-	1	
Installation Materials	CP19-02701	001-587-750	1	
	CP19-02702	001-587-760	1	
Cable Assembly	MJ-A3SPF0019-035C	000-156-058	1	
Accessories	FP26-00401	001-175-940	1	
Flush Mounting Template	C42-02003	001-197-909	1	
Operator's Guide	OSE-45120-*	000-197-102-**	1	
Installation Manual	IME-45090-*	000-197-907-**	1	
Spare Parts	SP19-01601	001-587-730	1	Replacement fuse. Type: FGB0-A 125V 5A PBF (glass tube)

*/**: Indicates minor version.

Optional supply

Name	Type	Code No.	Remarks
Front-mount Kit	OP19-25	001-568-779	(See packing list supplied with kit for contents.)
Network HUB	HUB-101	000-011-762	
NMEA Data Converter	IF-NMEA2K2	000-037-670	
Remote Control Unit	MCU-002	000-025-461	
	MCU-004	000-033-392	
	MCU-005	000-035-097	
Matching Box	MB-1100	000-027-226	Required for some transducers. See next page.
Junction Box	FI-5002	000-010-765	
Joint Box	TL-CAT-012	000-167-140	For LAN network
Network (LAN) Cable	MOD-Z072-020+	001-167-880	LAN cable, cross-pair, 2 m
	MOD-Z073-030+	000-167-171	LAN cable, straight, 2 pairs, 3 m
	MOD-Z072-050+	001-167-890	LAN cable, cross-pair, 5 m
	MOD-Z072-100+	001-167-900	LAN cable, cross-pair, 10 m
MJ Cable Assy.	MJ-A6SPF0016-005C	000-159-689	For FAX-30
CAN bus Cable Assy.	FRU-NMEA-PMMFF-010	001-533-060	1 m
	FRU-NMEA-PMMFF-020	001-533-070	2 m
	FRU-NMEA-PMMFF-060	001-533-080	6 m
	FRU-NMEA-PFF-010	001-507-010	1 m
	FRU-NMEA-PFF-020	001-507-030	2 m
	FRU-NMEA-PFF-060	001-507-040	6 m
	FRU-MM1MF1MF1001	001-507-050	
	FRU-MM1000000001	001-507-070	
FRU-MF000000001	001-507-060		
External Buzzer	OP03-136	000-086-443	Buzzer: PKB5-3A40

EQUIPMENT LISTS

Name	Type	Code No.	Remarks
Rectifier	RU-3423	000-030-443	
	PR-62	000-013-484	100 VAC
		000-013-485	110 VAC
		000-013-486	220 VAC
		000-013-487	230 VAC
RU-1746B-2	000-030-439		
Cable Assy.	FRU-F12F12-100C	001-560-390	
	FRU-F12F12-200C	001-560-400	
	FRU-F7F7-100C	001-560-420	
	FRU-F7F7-200C	001-560-430	
Transducer (for internal fish finder)	520-5PSD* ¹	000-015-204	600 W
	520-5MSD* ¹	000-015-212	
	525-5PWD* ¹	000-146-966	
	525STID-MSD* ¹	000-011-783	
	525STID-PWD* ¹	000-011-784	
	520-PLD* ¹	000-023-680	
	525T-BSD* ¹	000-023-020	
	525T-PWD* ¹	000-023-019	
	525T-LTD/12* ¹	000-023-679	
	525T-LTD/20* ¹	000-023-678	
	SS60-SLTD/12* ¹	000-023-676	
	SS60-SLTD/20* ¹	000-023-677	
	526TID-HDD* ¹	000-023-021	1 kW
	50/200-1T *10M* * ¹	000-015-170	1 kW
	50B-6 *10M*	000-015-042	Matching box MB-1100 required for installation of these transducers.
50B-6B *15M*	000-015-043		
200B-5S *10M*	000-015-029		
CHIRP Transducer (for internal fish finder)	TM150M	000-035-500	300 W
	B-75L	000-035-501	
	B-75H	000-035-502	600 W
	B-175H	000-035-504	1 kW
	B-175L	000-035-503	
Thru-Hull Pipe	TRB-1100(1)	000-027-409	
	TRB-1000(1)	000-015-215	
	TRB-1100(2)	000-015-218	
	TFB-4000(1)	000-015-205	
	TFB-5000(1)	000-015-206	
	TWB-6000(2)	000-015-207	
	TFB-7000(1)	000-022-532	
	TFB-7000(2)	000-015-209	
Extension Cable* ²	C332 10M	001-464-120	

*¹: Compatible with ACCU-FISH™, Bottom Discrimination and RezBoost™ Enhanced mode. All other listed transducers, however, are compatible with RezBoost™ Standard mode.

*²: Use of the extension cable may cause the following problems:

- Reduced detection ability
- Wrong ACCU-FISH™ information (fish length smaller than actual length, fewer fish detections, error in individual fish detection).
- Wrong speed data
- No TD-ID recognition

Other compatible transducers (local supply)

The transducers (Manufactured by AIRMAR Technology Corporation) listed in the table below are compatible with this equipment. Contact your local FURUNO dealer for purchase.

Single Frequency CHIRP (For internal fish finder)

Output power	Model					
300 W	B150M	SS75L				
600 W	B75M	B785M	SS75M	SS75H		
1 kW	B175M	B175HW	TM185M	TM185HW	B285M	B285HW

This page is intentionally left blank.

1. MOUNTING

1.1 Installation of Multi Function Display

The TZT9F is designed to be mounted in a console or panel, or mounted on a desktop.

The installer of this equipment must read and follow the descriptions in this manual. Wrong installation or maintenance can void the warranty.

Mounting considerations

When selecting a mounting location for your TZT9F, keep the following in mind:

- The temperature at the mounting location shall be between -15°C and +55°C.
- The humidity at the mounting location shall be 93% or less at 40°C.
- Locate the unit away from exhaust pipes and ventilators.
- The mounting location should be well ventilated.
- Mount the unit where shock and vibration are minimal (compliant with IEC 60945 Ed.4).
- Keep the unit away from electromagnetic field generating equipment such as motors and generators.
- For maintenance and checking purposes, leave sufficient space around the unit and leave slack in cables. Minimum recommended space is shown in the outline drawing for the display units.
- Do not mount the unit on an overhead beam/bulkhead.
- A magnetic compass will be affected if the equipment is placed too close to it. Observe the compass safe distances shown in the SAFETY INSTRUCTIONS to prevent disturbance to the magnetic compass.
- You can install multiple TZtouch3 units side-by-side when flush mounting. Keep a minimum of 29 mm between each cutout for access to fixtures and wing-bolts.

1. MOUNTING

1.1.1 Desktop mounting

Your TZT9F is shipped with a bracket for desktop mounting. The following procedure shows how to install the unit on a desktop.

1. Place the unit face-down on a soft/clean surface, then unfasten the knob bolts on either side of the unit.

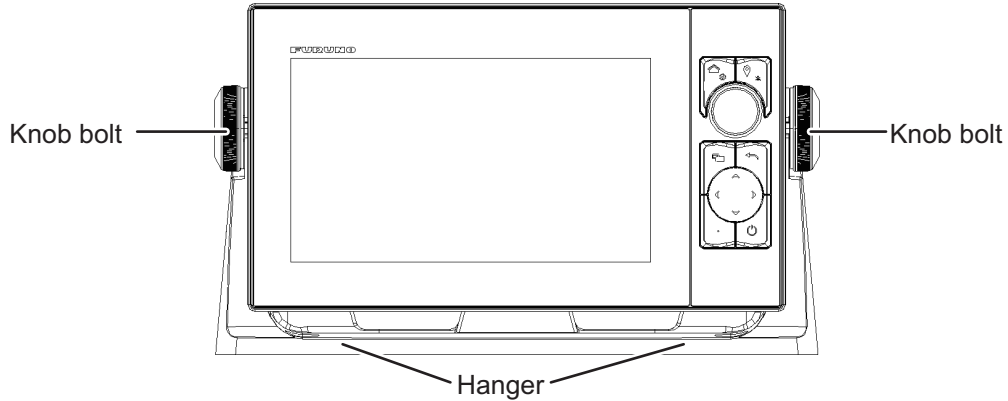

2. Separate the hanger from the unit. If the hanger does not release easily, gently move the arms of the hanger outwards as you separate it from the unit.
3. Fix the hanger to the installation location by using the supplied self-tapping screws (5×20 SUS304). The screw locations are indicated in the figure below.

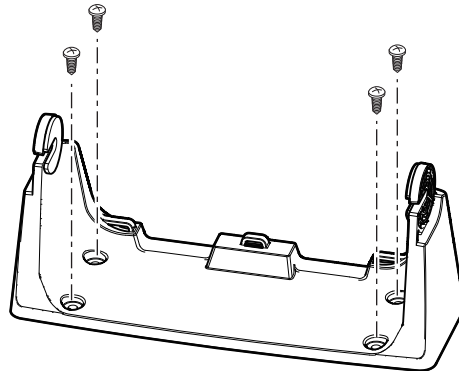

4. Fit the knob bolts as shown in the figure below, leaving a gap of 10 to 13 mm.

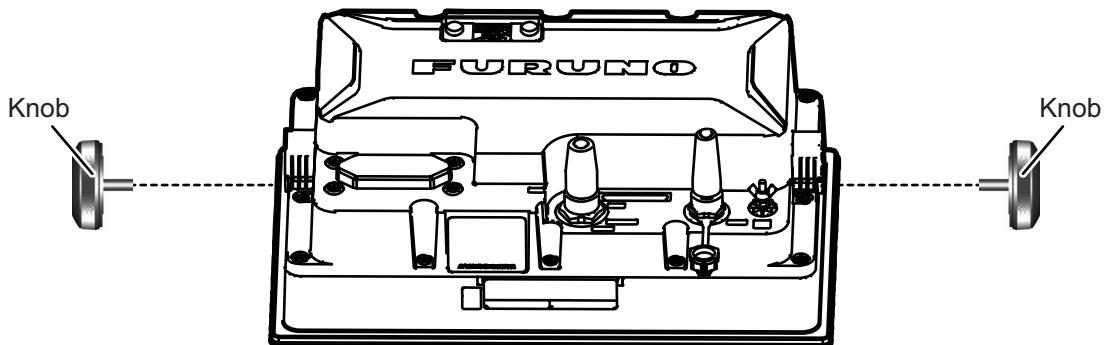

5. Set the TZT9F unit to the hanger and tighten the knob bolts.

1.1.2 Flush mounting

Referring to the figure below, select a flat mounting location. Read the installation instructions before starting. Pay particular attention to the notes; failure to follow these instructions may cause damage to the unit.

Note: Ensure the mounting location is flat, with no indents or protrusions, to allow a secure fit.

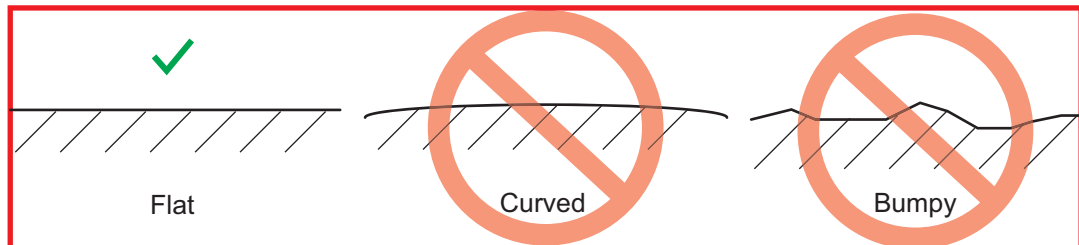

1. Place the unit face-down on a soft/clean surface, then unfasten the knob bolts on either side of the unit.

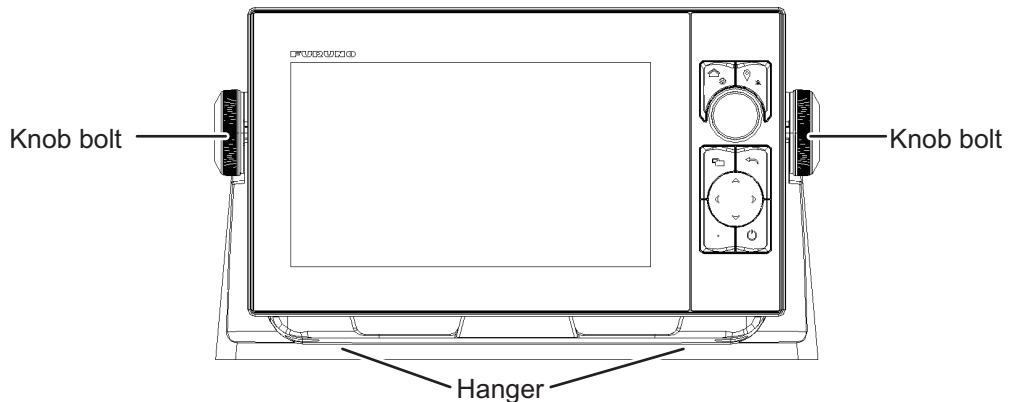

2. Separate the hanger from the unit. If the hanger does not release easily, gently move the arms of the hanger outwards as you separate it from the unit.
3. Prepare a cutout in the mounting location using the template (supplied) for the TZT9F.
4. Fasten the wing bolts and the wing nuts of the flush mount fixture so that the protector for screw moves to the flush mount fixture.

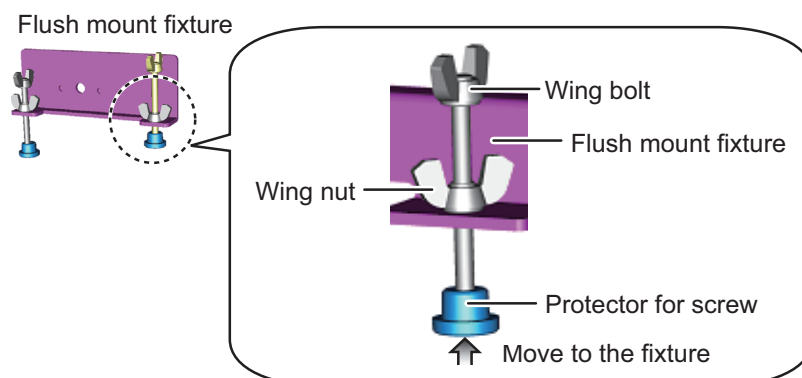

Note: Slowly fasten the four wing bolts evenly with your hand. Do not use a tool to fasten the wing bolts. A tool can be used to fasten the wing nuts; use caution so as not to damage the wings or thread.

1. MOUNTING

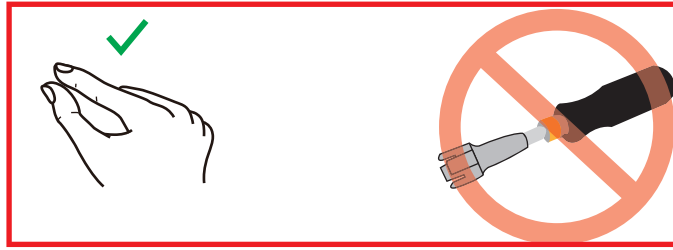

- 5. Connect all cables at the back of the TZT9F. (See section 2.1)
- 6. Attach flush mount sponges to the bezel of TZT9F.

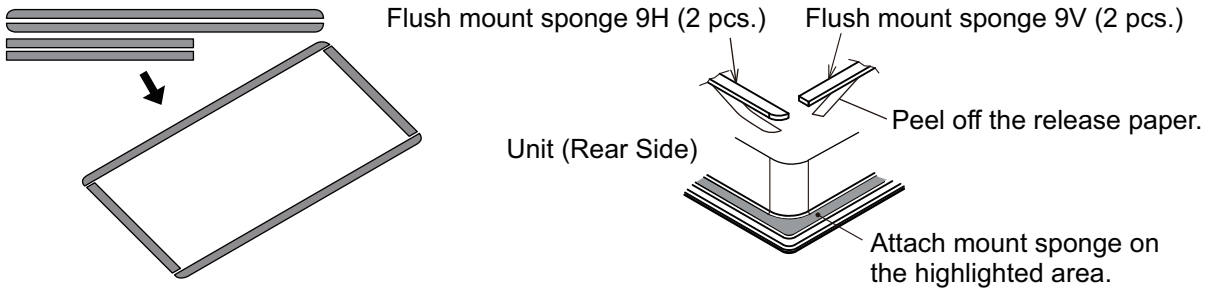

- 7. Set TZT9F to the cutout made at step 3.

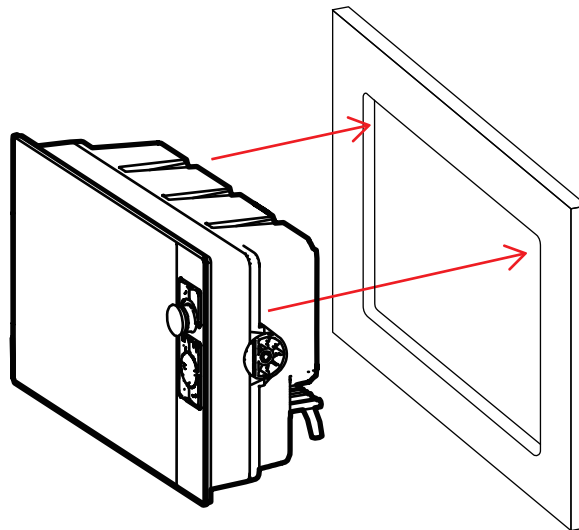

- 8. Attach the flush mount fixture to the TZT9F with hex bolts.

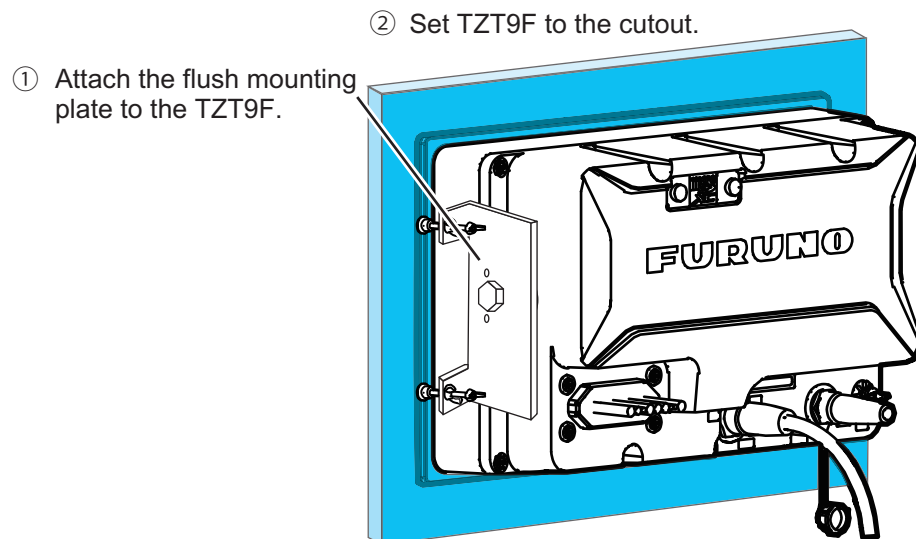

9. Fasten each wing bolt (4 pcs.) so that the protector for screw touches the mounting panel.
10. Fasten the wing nuts tightly.

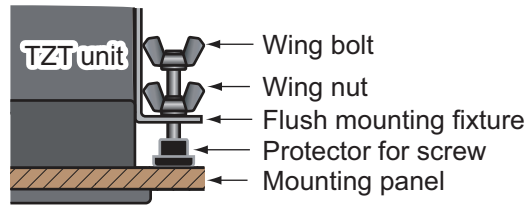

Note: Use of excessive torque when fastening the wing bolts can cause the flush mount fixture to tilt or warp. Check that the flush mount fixtures and wing bolts are not tilted or warped, referring to the following examples.

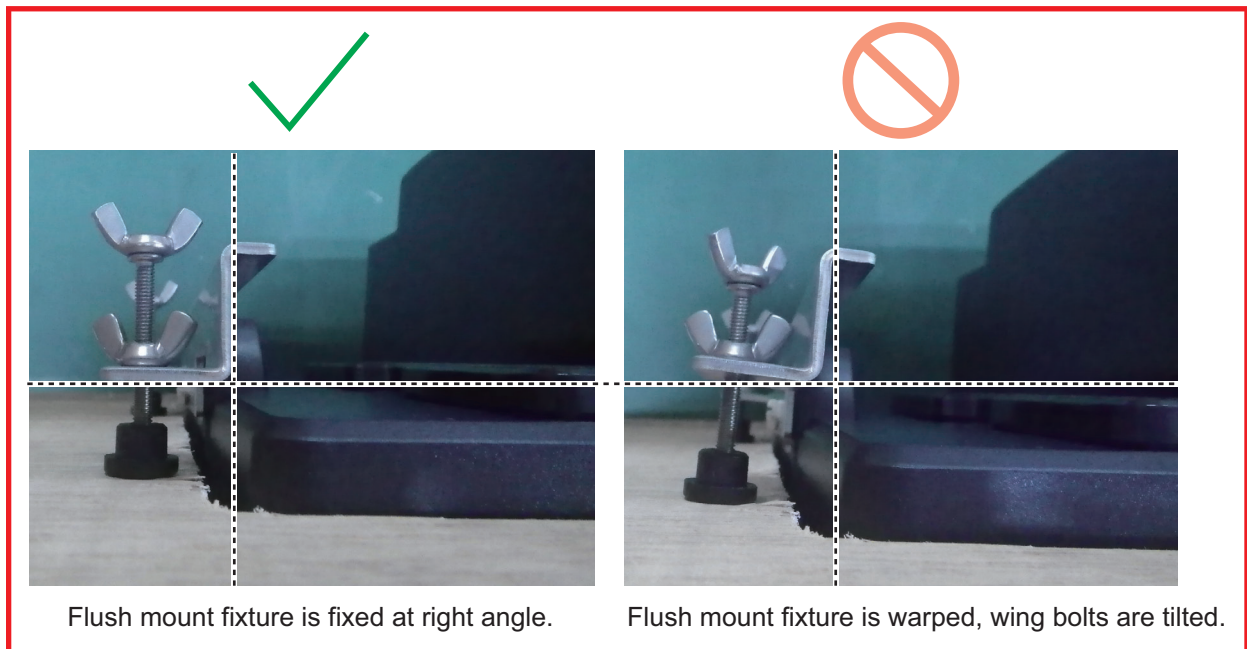

1.1.3 Retrofit Kit for TZT9F (option)

When upgrading to the TZT9F, use the Front Fixing Panel Kit (OP19-25).

Type: OP19-25 Code No. 001-587-790

Name	Type	Code No.	Qty
F Mount Panel 9	19-034-1081-1	100-435-771	1
Self-tapping screw	5×20 SUS304	000-160-609	4

1. Prepare a cutout in the mounting location using the template (supplied) for the TZT9F.
2. Place the TZT9F unit face-down on a soft, clean surface.

1. MOUNTING

3. Set the F Mount Panel to the TZT9F unit, then using the hex bolts attached to TZT9F, fix the F Mount Panel to the unit.

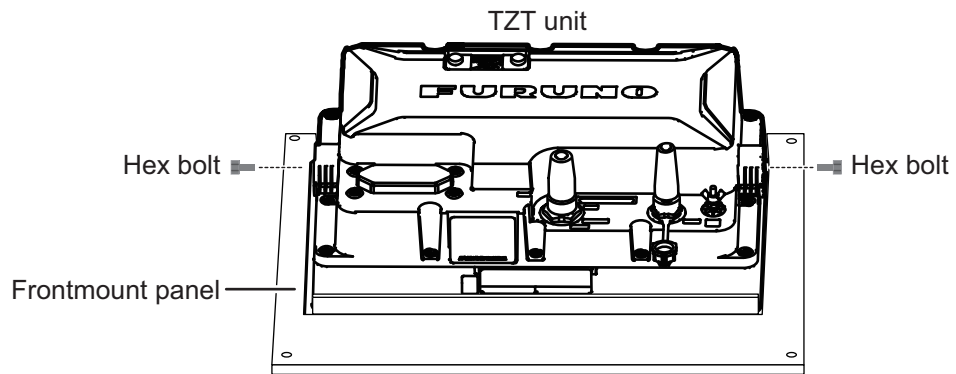

4. Connect necessary cable, referring to chapter 2.
5. Set the unit and F Mount Panel into the cutout as shown in the below figure, then use the supplied self-tapping screws (5×20 SUS304 × 4 pcs.), to fix the F Mount Panel to the console.

Note: Be careful not to pinch the cables connected at step 4.

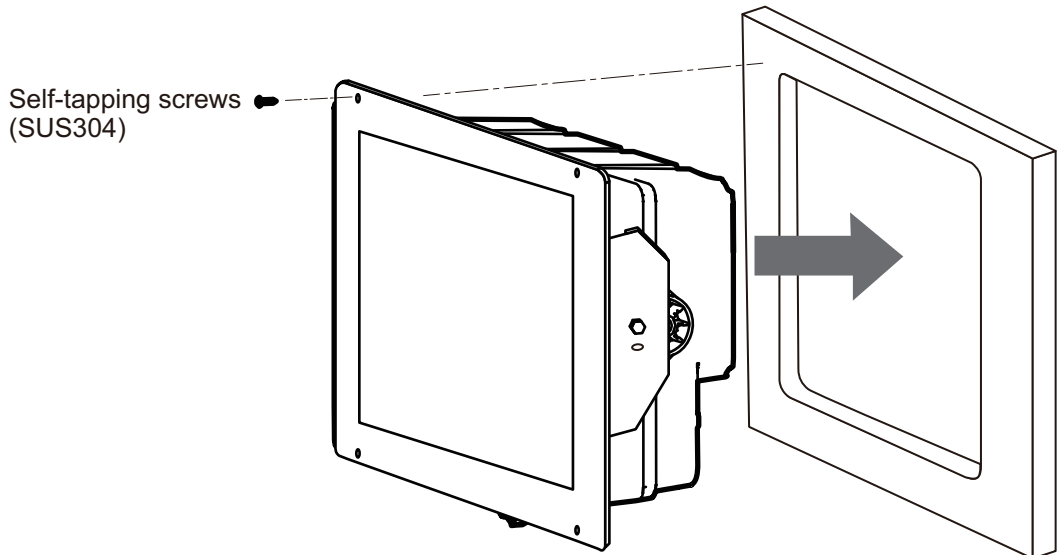

Note: Where the mounting location may be exposed to water (spray or splash), apply a bead of marine sealant around the rear of the F Mount Panel, for waterproofing, before setting the F Mount Panel and unit into the cutout. Wipe the area clean to remove any marine sealant residue and allow time for the marine sealant to dry.

1.2 Installation of Transducers

⚠ CAUTION



Do not cover the transducer with FRP resin.

The heat generated when the resin hardens may damage the transducer. CHIRP transducers are especially vulnerable to heat.

Note: For instructions regarding installation of network fish finder transducers, see the respective manual.

There are three methods for installing the transducer on the ship (thru-hull mount, inside the hull and transom mount) and one of those methods is to be selected according to the structure of the ship. The procedure which follows below shows how to install a small transducer (520-5PSD/5MSD) as the representative example of installation.

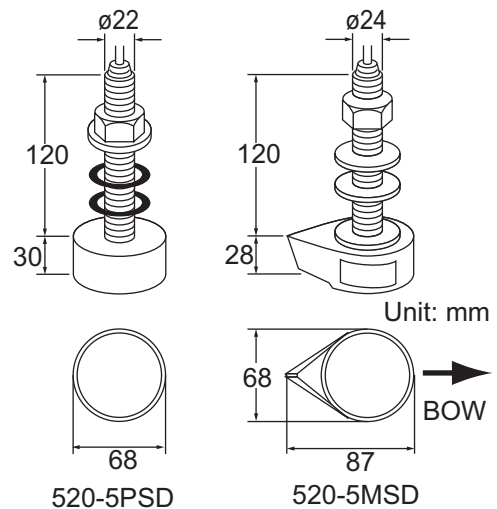

1.2.1 How to mount a transducer through the hull

Transducer mounting location

The thru-hull mount transducer provides the best performance of all, since the transducer protrudes from the hull and the effect of air bubbles and turbulence near the hull skin is reduced. If your boat has a keel, the transducer should be at least 30 cm away from it.

The performance of this fish finder is directly related to the mounting location of the transducer, especially for high-speed cruising. The installation should be planned in advance, keeping the length of the transducer cable and the following factors in mind:

- Air bubbles and turbulence caused by movement of the boat seriously degrade the sounding capability of the transducer. The transducer should, therefore, be located in a position where water flow is the smoothest. Noise from the propellers also adversely affects performance and the transducer should not be mounted nearby. The lifting strakes are notorious for creating acoustic noise, and these must be avoided by keeping the transducer inboard of them.

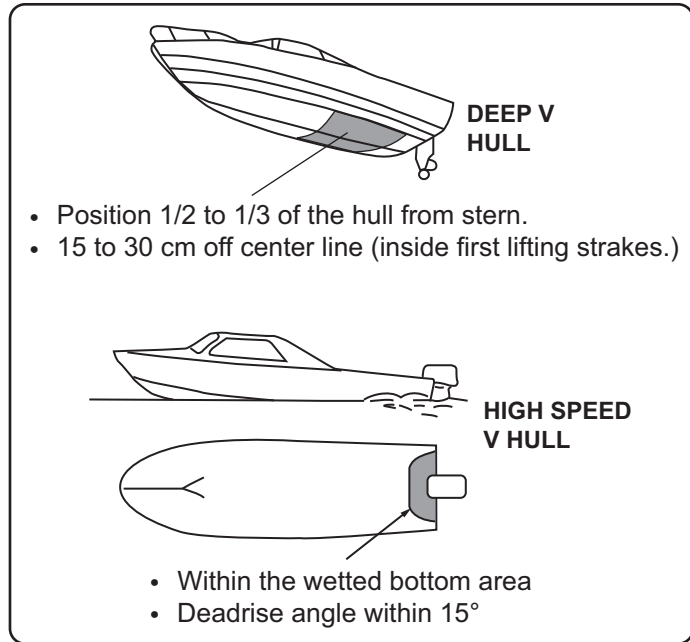

- The transducer must always remain submerged, even when the boat is rolling, pitching or up on a plane at high speed.
- A practical choice would be somewhere between 1/3 and 1/2 of your boat's length from the stern. For planing hulls, a practical location is generally rather far astern, so that the transducer is always in water regardless of the planing attitude.

Installation procedure

1. With the boat hauled out of the water, mark the location chosen for mounting the transducer on the bottom of the hull.
2. If the hull is not level within 15° in any direction, fairing blocks made out of teak should be used between the transducer and hull, both inside and outside, to keep the transducer face parallel with the water line. Fabricate the fairing block as shown below and make the entire surface as smooth as possible to provide an undisturbed flow of water around the transducer. The fairing block should be smaller than the transducer itself to provide a channel to divert turbulent water around the sides of the transducer rather than over its face.

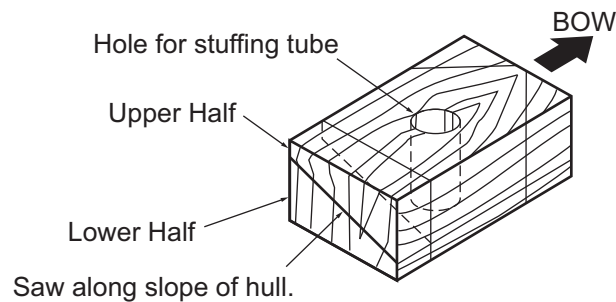

3. Drill a hole just large enough to pass the threaded stuffing tube of the transducer through the hull, making sure it is drilled vertically.
4. Apply a sufficient amount of high quality caulking compound to the top surface of the transducer, around the threads of the stuffing tube and inside the mounting hole (and fairing blocks if used) to ensure watertight mounting.
5. Mount the transducer and fairing blocks and tighten the locknut. Be sure that the transducer is properly oriented and its working face is parallel to the waterline.

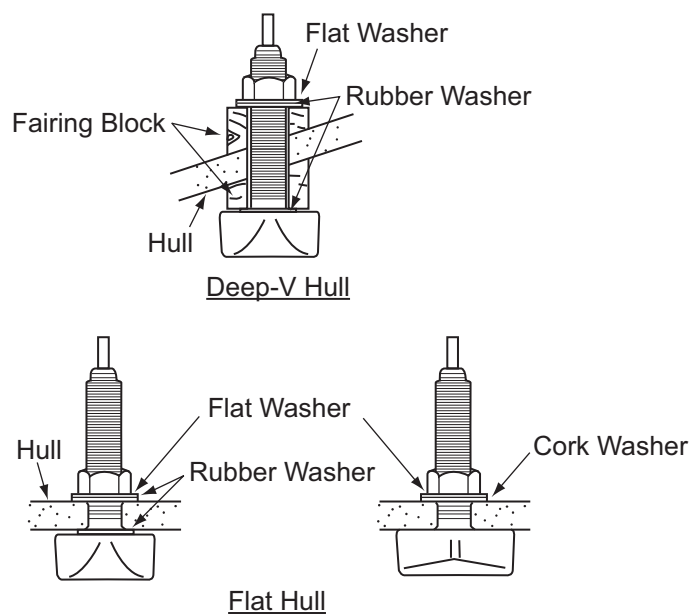

Note: Do not over-stress the stuffing tube and locknut through excessive tightening, since the wood block will swell when the boat is placed in the water. It is suggested that the nut be tightened lightly at installation and re-tightened several days after the boat has been launched.

1. MOUNTING

1.2.2 How to mount a transducer inside the hull

NOTICE

This installation method affects the ability to detect the bottom, fish and other objects because the ultrasound pulse is weakened when it passes through the hull.

Therefore, refrain from this mounting method for a transducer that supports the RezBoost™ (Enhanced Mode), ACCU-FISH™ and/or bottom discrimination display feature.

Remarks on installation

This method is useful when mounting a transducer inside the hull of FRP ship, however, it affects the ability to detect the bottom, fish and other objects.

- Do the installation with the ship moored at a dock, etc. The water depth should be 6.5 to 32 feet (2 to 10 meters).
- Turn off the engine.
- Do not power the unit with the transducer in the air, to prevent damage to the transducer.
- Do not use this method on a double layer hull.
- Before attaching the transducer to the hull, check that the site is suitable, by following steps 1 to 3 in the installation procedure below.

Necessary tools

The following tools are required:

- Sandpaper (#100)
- Marine sealant
- Water-filled plastic bag

Selecting a location to install the transducer



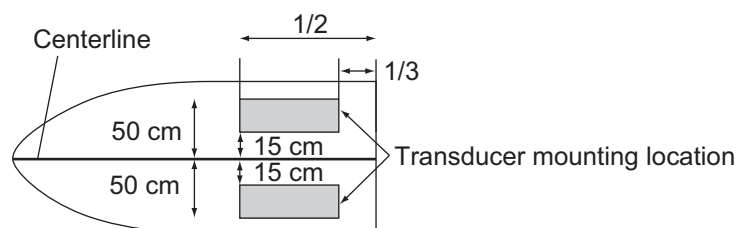

Install the transducer on the hull plate inside of the engine room. The attenuation of the ultrasound pulse varies with the thickness of the hull. Select a location where attenuation is the lowest.

Select 2-3 locations considering the four points mentioned below.

- Mount the transducer at a location $1/2$ to $1/3$ of the length of your boat from the stern.
- The mounting location is between 15 to 50 cm from the centerline of the hull.
- Do not place the transducer over hull struts or ribs which run under the hull.
- Avoid a location where the rising angle of the hull exceeds 15° , to minimize the effect of the boat's rolling.



Decide the most suitable site from the locations selected with the following procedures.

1. Connect the power cable and transducer cable to the display unit.
2. Put the transducer into a water-filled plastic bag. Press the transducer against the chosen site.
3. Tap  (power switch) to turn the power on.
4. After the startup procedure completes (approx. 90 seconds), the last used display appears. Tap the [Home] icon () to show the home screen and display mode settings. See section 3.3 for how to use the menu.
5. Scroll the menu to show [Fish Finder] in the menu, then tap [Fish Finder].
6. Scroll the [Fish Finder] menu to show the [FISH FINDER INITIAL SETUP] menu, then tap [Fish Finder Source].
7. Confirm the available fish finder from the list of available sounders, then tap the appropriate fish finder. For the purpose of this example, the default setting [TZT9F] (internal sounder) is selected as the source.
8. Tap the [<] icon to return to the [Fish Finder] menu.
9. Scroll the [Fish Finder] menu to show the [FISH FINDER INITIAL SETUP] menu, then tap [Transducer Setup].
10. Tap [Transducer Setup Type].
11. Tap [Model].
12. Tap the [<] icon to return to [Transducer Setup] menu.
13. Tap [Model Number], scroll the menu to show your transducer model, then tap the transducer model number.
14. Tap the [<] icon twice to return to the [Fish Finder] menu, then scroll the [Fish Finder] to show the [FISH FINDER INITIAL SETUP] menu.
15. At the [Transmission Power] menu item, set the transmission power to a level of [Max].
16. Scroll the menu to show [Fish Finder Transmit], then tap [Fish Finder Transmit]. Check if the bottom echo appears on the right side of the screen, in the display area.
If no bottom echo appears, repeat the procedure until a suitable location is found.
17. Turn off the power of control unit and remove the transducer from the plastic bag and wipe the face of transducer with a cloth to remove water and any foreign material.

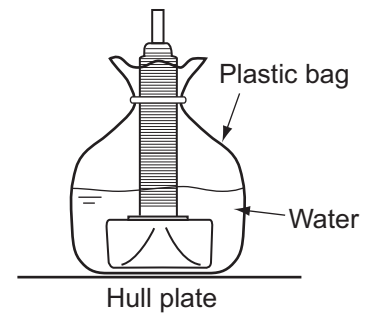

1. MOUNTING

Installation procedure

1. Lightly roughen the transducer face with #100 sandpaper. Also, use the sandpaper to roughen the inside of the hull where the transducer is to be mounted. Wipe off any sandpaper dust from the face of the transducer.
2. Dry the face of the transducer and the hull. Coat the transducer face and mounting location with marine sealant. Hardening begins in approx. 15 to 20 minutes so do this step without delay.

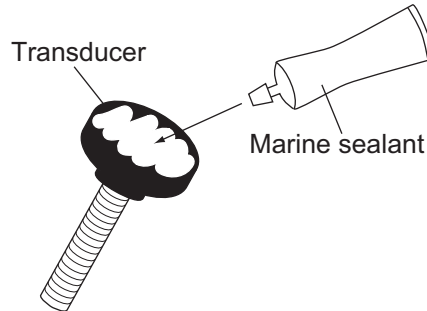

3. Attach the transducer to the hull. Press the transducer firmly down on the hull and gently twist it back and forth to remove any air which may be trapped in the marine sealant.

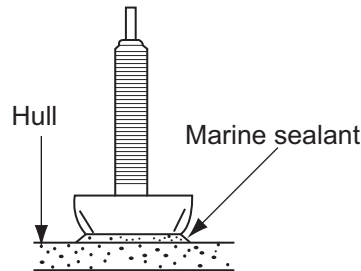

4. Support the transducer with a piece of wood to keep it in place while the sealant is drying. It takes 24 to 72 hours to harden completely.
5. Turn the power on and change the menu setting as shown below. See section 3.3 for how to use the menu.
 - 1) Tap the [Home] icon to show the home screen and display mode settings.
 - 2) Scroll the menu to show [Fish Finder] in the menu, then tap [FISH FINDER INITIAL SETUP] menu.
 - 3) At the [Transmission Power Mode] menu item, set the transmission power to a level of [Max].
 - 4) Adjust the Bottom Level and Gain Offset settings as shown in the table below.

Menu Item	Setting
Bottom Level HF	-40
Bottom Level LF	-40
Gain Offset HF	20
Gain Offset LF	20

1.2.3 How to install the transom mount transducer

The optional transom mount transducer is very commonly employed, usually on relatively small I/O or outboard boats. Do not use this method on an inboard motor boat because turbulence is created by the propeller ahead of the transducer.

DO NOT over-tighten screws, to prevent damage to the transducer.

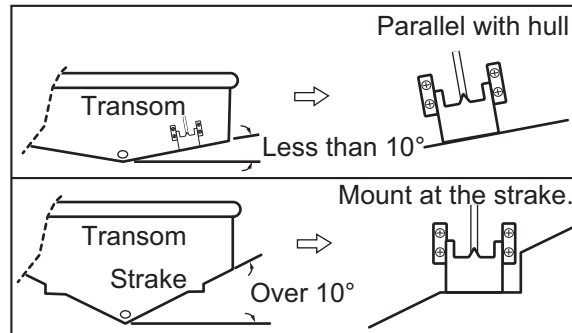

Installation procedure

A suitable mounting location is at least 50 cm away from the engine and where the water flow is smooth.

1. Drill four pilot holes for self-tapping screw (5×20) in the mounting location.
2. Coat the threads of the self-tapping screws (5×14) for the transducer with marine sealant for waterproofing. Attach the transducer to the mounting location with the self-tapping screws.
3. Adjust the transducer position so the transducer faces right to the bottom. If necessary, to improve water flow and minimize air bubbles staying on the transducer face, incline the transducer about 5° at the rear. This may require a certain amount of experimentation for fine tuning at high cruising speeds.
4. Tape the location shown in the figure below.
5. Fill the gap between the wedge front of the transducer and transom with epoxy material to eliminate any air spaces.
6. After the epoxy hardens, remove the tape.

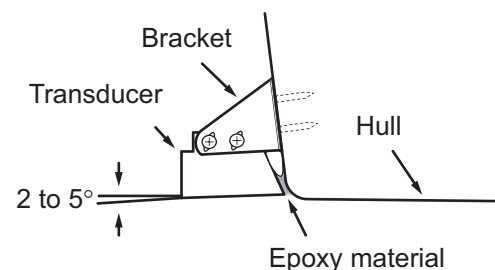
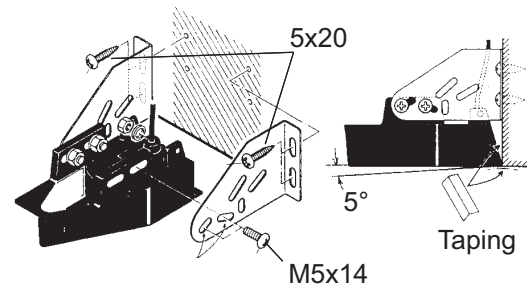

Transducer protrusion

If the hull is not level within 15° in any direction, install the transducer so that it protrudes from the hull, to keep the transducer face parallel with the water line, not with the hull.

This installation method has a merit for avoiding the bubbles by diverting turbulent water around the sides of the transducer rather than over its face. However, it may cause damage to the transducer during trailering, launching, hauling, and storage.

1. MOUNTING

Transducer preparation

Before putting your boat in water, wipe the face of the transducer thoroughly with a liquid detergent. This will lessen the time necessary for the transducer to have good contact with the water. Otherwise the time required for complete "saturation" will be lengthened and performance will be reduced.

DO NOT paint the transducer. Performance will be affected.

1.2.4 How to install a triducer

DO NOT over-tighten screws, to prevent damage to the transducer.

Tools and materials required

- Scissors
- Safety goggles
- Electric drill
- Drill bit:
For bracket holes: 4 mm, #23, or 9/64"
For fiberglass hull: chamfer bit (preferred), 6 mm, or 1/4"
For transom hole: 9 mm or 3/4" (optional)
For cable clamp holes: 3 mm or 1/8"
- Straight edge
- Pencil
- Water-based anti-fouling paint (mandatory in salt water)
- Masking tape
- Dust mask
- Screwdrivers
- Marine sealant
- Cable ties

525STID-MSD

The optional triducer 525STID-MSD is designed for thru-hull mounting. Note the following points when installing.

- Select a location where turbulence or bubbles do not occur when cruising.
- Select a location where noises from propellers and stripe lines are less.
- The transducer must always remain submerged, even when the boat is rolling, pitching or up on a plane at high speed.

525STID-PWD

The optional triducer 525STID-PWD is designed for transom mounting.

However, select the location where influences from bubbles and turbulences to ensure the best performance. Allow adequate space above the bracket for it to release and rotate the sensor upward as shown in the right illustration.

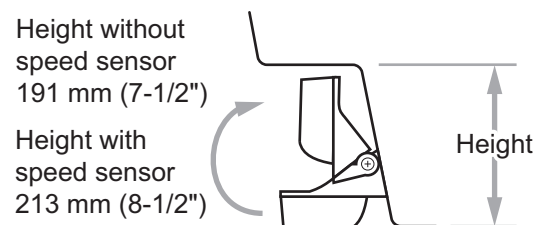
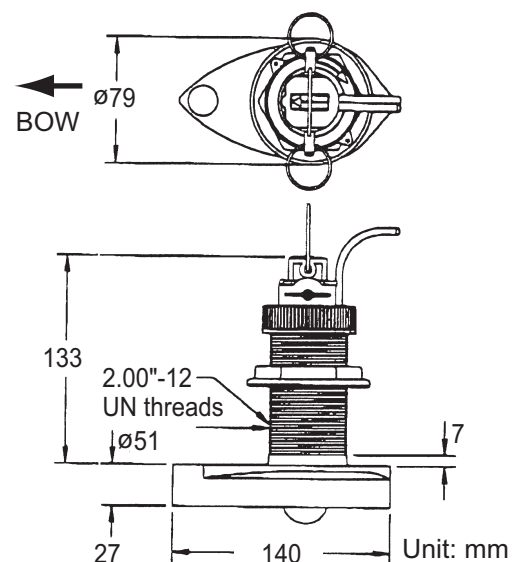

1. MOUNTING

Mount the sensor close to the centerline of your boat. On slower heavier displacement hulls, positioning it farther from the centerline is acceptable.

For single drive boat, mount on the star-board side at least 75 mm (3") beyond the swing radius of the propeller, as shown in the right figure.

For twin drive boat, mount between the drives.

Note 1: Do not mount the sensor in an area of turbulence or bubbles, near water in-take or discharge openings; behind strakes, struts, fittings, or hull irregularities; behind eroding paint (an indication of turbulence).

Note 2: Avoid mounting the sensor where the boat may be supported during trailering, launching, hauling, and storage.

Pretest for speed and temperature

Connect the sensor to the instrument and spin the paddlewheel. Check for a speed reading and the approximate air temperature. If there is no reading, return the sensor to your place of purchase.

How to install the bracket

1. Cut out the installation template (enclosed with transducer) along the dotted line.
2. At the selected location, position the template, so the arrow at the bottom is aligned with the bottom edge of the transom. Being sure the template is parallel to the waterline, tape it in place.

Warning: Always wear safety goggles and a dust mask.

3. Using a 4 mm, #23, or 9/64" bit, drill three holes 22 mm (7/8") deep at the locations indicated. To prevent drilling too deeply, wrap masking tape around the bit 22 mm (7/8") from the point.

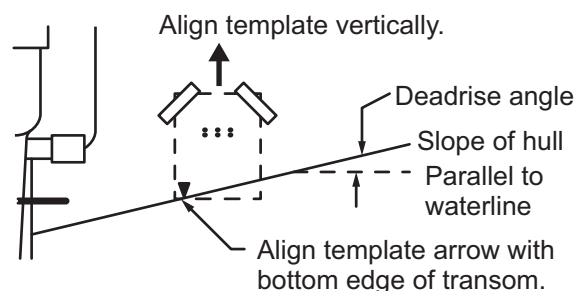

Fiberglass hull: Minimize surface cracking by chamfering the gelcoat. If a chamfer bit or countersink bit is not available, start drilling with a 6mm or 1/4" bit to a depth of 1 mm (1/16").

4. If you know your transom angle, the bracket is designed for a standard 13° transom angle.
11°-18° angle: No shim is required. Skip to step 3 in "Adjustments".
Other angles: The shim is required. Skip to step 2 of "Adjustments".
If you do not know the transom angle, temporarily attach the bracket and sensor to the transom to determine if the plastic shim is needed.
5. Using the three #10 x 1-1/4" self-tapping screws, temporarily screw the bracket to the hull. DO NOT tighten the screws completely at this time. Follow steps 1-4 in "How to attach the sensor to the bracket", before proceeding with "Adjustments".

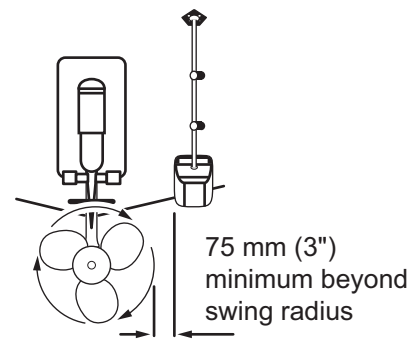

Adjustments

- Using a straight edge, sight the underside of the sensor relative to the underside of the hull. The stern of the sensor should be 1-3 mm (1/16-1/8") below the bow of the sensor or parallel to the bottom of the hull.

Note: Do not position the bow of the sensor lower than the stern because aeration will occur.

- To adjust the sensor's angle relative to the hull, use the tapered plastic shim provided. If the bracket has been temporarily fastened to the transom, remove it. Key the shim in place on the back of the bracket.

2°-10° transom angle (stepped transom and jet boats): Position the shim with the tapered end down.

19°-22° transom angle (small aluminum and fiberglass boats): Position the shim with the tapered end up.

- If the bracket has been temporarily fastened to the transom, remove it. Apply a marine sealant to the threads of the three #10x1-1/4" self-tapping screws to prevent water seeping into the transom. Screw the bracket to the hull. Do not tighten the screws completely at this time.

- Repeat step 1 to ensure that the angle of the sensor is correct.

Note: Do not position the sensor farther into the water than necessary to avoid increasing drag, spray, and water noise and reducing boat speed.

- Using the vertical adjustment space on the bracket slots, slide the sensor up or down to provide a projection of 3 mm (1/8"). Tighten the screws.

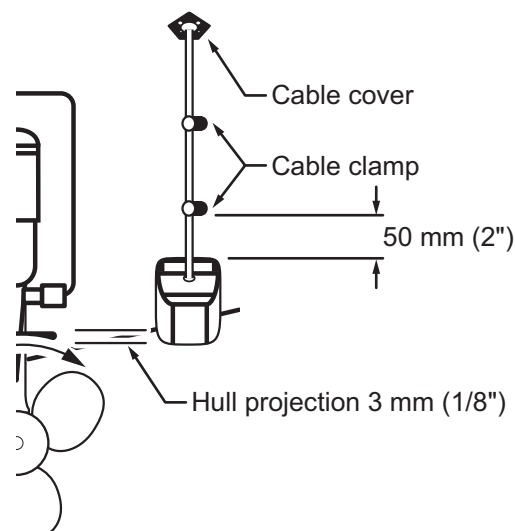
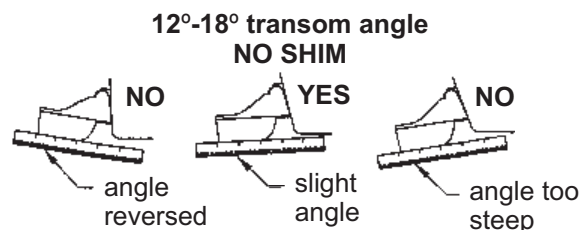
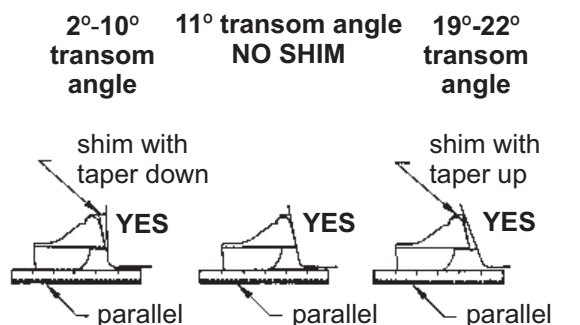

1. MOUNTING

How to attach the sensor to the bracket

1. If the retaining cover near the top of the bracket is closed, open it by depressing the latch and rotating the cover downward.
2. Insert the sensor's pivot arms into the slots near the top of the bracket.
3. Maintain pressure until the pivot arms click into place.
4. Rotate the sensor downward until the bottom snaps into the bracket.
5. Close the retaining cover to prevent the accidental release of the sensor when your boat is underway.

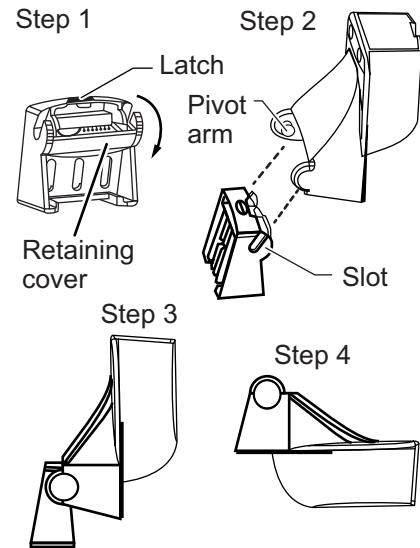

How to route the cable

Route the sensor cable over the transom, through a drain hole, or through a new hole drilled in the transom above the waterline. If a hole must be drilled, choose a location well above the waterline. Check for obstructions such as trim tabs, pumps, or wiring inside the hull. Mark the location with a pencil. Drill a hole through the transom using a 19 mm or 3/4" bit (to accommodate the connector). Always wear safety goggles and a dust mask.



1. Route the cable over or through the transom. On the outside of the hull secure the cable against the transom using the cable clamps. Position a cable clamp 50 mm (2") above the bracket and mark the mounting hole with a pencil.
2. Position the second cable clamp halfway between the first clamp and the cable hole. Mark this mounting hole.
3. If a hole has been drilled in the transom, open the appropriate slot in the transom cable cover. Position the cover over the cable where it enters the hull. Mark the two mounting holes.
4. At each of the marked locations, use a 3 mm or 1/8" bit to drill a hole 10 mm (3/8") deep. The prevent drilling too deeply, wrap masking tape around the bit 10 mm (3/8") from the point.
5. Apply marine sealant to the threads of the #6 x 1/2" self-tapping screw to prevent water from seeping into the transom. If you have drilled a hole through the transom, apply marine sealant to the space around the cable where it passes through the transom.
6. Position the two cable clamps and fasten them in place. If used, push the cable cover over the cable and screw it in place.
7. Route the cable to the display unit being careful not to tear the cable jacket when passing it through the bulkhead(s) and other parts of the boat. To reduce electrical interference, separate the sensor cable from other electrical wiring and "noise" sources. Coil any excess cable and secure it in place with zip-ties to prevent damage.

2. WIRING

2.1 Interface Connections (Rear of Unit)

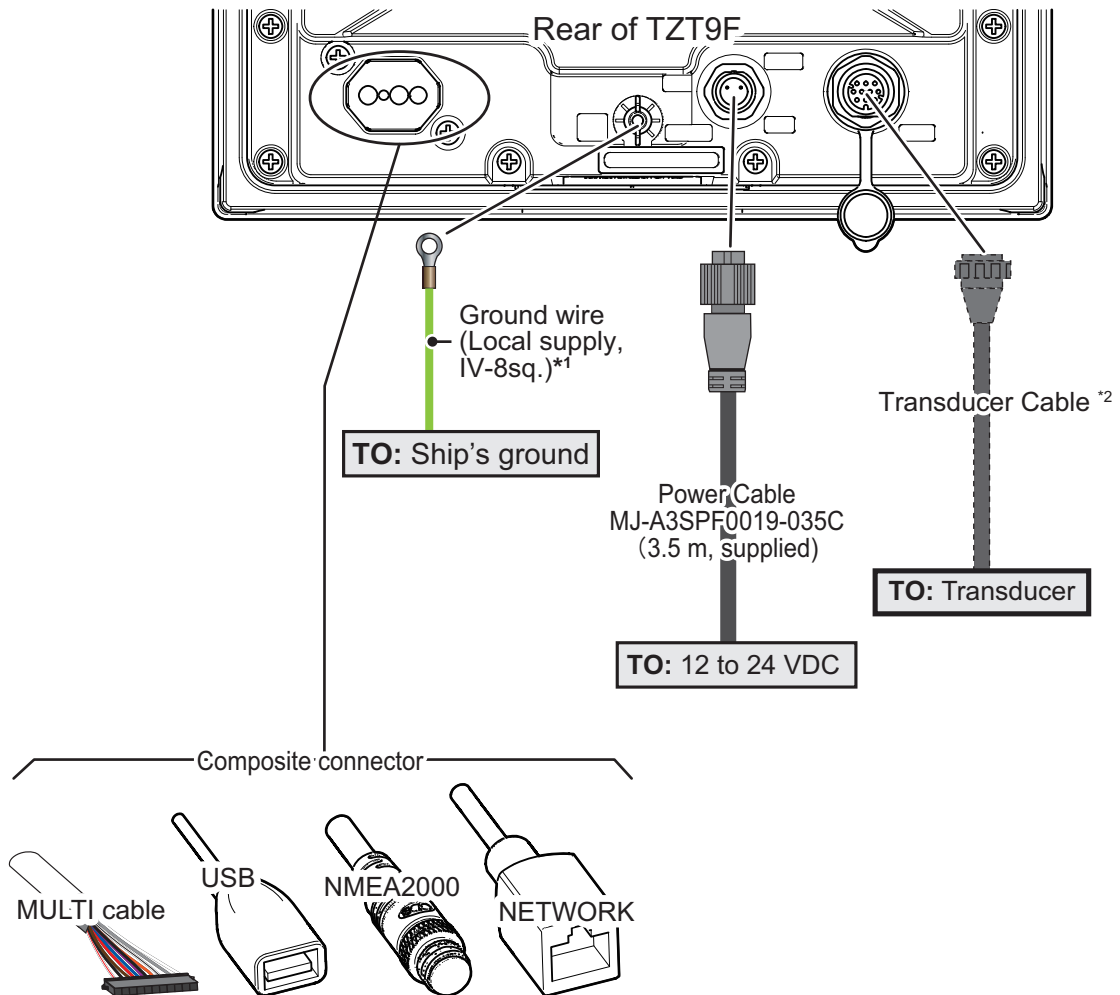

*1: Lay the ground wire away from this unit's power cable.

*2: Use of the extension cable (C332 10M) may cause the following problems:

- Reduced detection ability
- Wrong ACCU-FISH™ information (fish length smaller than actual length, fewer fish detections, error in individual fish detection).
- Wrong speed data
- No TD-ID recognition

2.2 Composite Connector

The composite connector, at the rear of the unit (See the figure on page 2-1), contains connection leads for LAN, NMEA2000, MULTI and USB.

Network

You can connect to an external network device using a LAN cable. Use HUB-101 (option) when connecting multiple devices. The MCU-005 can be also used by using a PoE hub.

NMEA2000 (CAN bus port)

TZT9F can be connected to multiple NavNet TZtouch3 using the CAN bus connector (micro type). In that case, connect them all to the same CAN bus backbone cable, See section 2.8 for details).

MULTI port

You can connect to external devices such as buzzers and event switches. See section 2.5 for details.

USB port

The TZT9F has one USB Ver. 2.0 port which can be used to connect an optional SD card unit or remote control unit, and to be operated from touch device or PC mouse.

2.3 How to Secure and Waterproof Connections

Where the unit is exposed to water spray or moisture, all the connectors and MULTI cable connections to the TZT9F must have at least IPx2 waterproof rating.

All unused cable ends should be covered for protection.

Securing and waterproofing connections

1. Wrap the connection point in vulcanizing tape, covering at approximately 30 mm of the connecting cable.
2. Wrap the vulcanizing tape with vinyl tape, covering approx. 50 mm of the connecting cable. Bind the tape ends with cable ties to prevent the tape from unraveling.

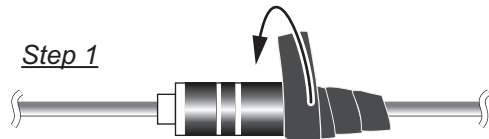

Step 1

Wrap connection in vulcanizing tape for waterproofing.



Step 2

Wrap vulcanizing tape in vinyl tape, then secure tape ends with cable ties.

Securing and protecting unused cable connectors

1. Place the cap and cover the cable connector with vinyl tape.
2. Wrap the connector, covering approx. 50 mm of the connecting cable.
3. Bind the tape end with a cable tie to prevent the tape from unraveling.

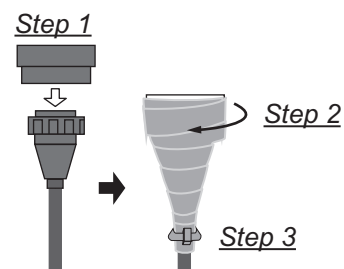

Step 1

Step 2

Step 3

2.4 Power Cable

Connect the power cable (FRU-3P-FF-A002M-000, 2m, supplied) to the connector. When connecting the power supply, connect the positive and negative terminals correctly.

Note: Turn off the power at the switchboard before beginning the connection.

Ground wire

Connect the ground wire (IV-8sq, local supply) to the ground terminal on the rear panel with the crimp terminal.



2.5 MULTI Cable

Use the MULTI cable for the NMEA0183 equipment, external buzzer, event switch and power switch. The connector has 9 wires and a connector (SMP-11V). Use the table below for reference when connecting the MULTI cable.

Wire color	Function	Pin No.	Remark (Port No.)
White	NMEA-TD-A	1	NMEA0183 Output
Blue	NMEA-TD-B	2	
Gray	EXT_BUZZER	3	External buzzer ON/OFF
Red	+12 V	4	External buzzer power (12 V)
Orange	EVENT_SW	5	Event switch (MOB, etc.)
Black	GND	6	Grounding
Purple	POWER_SW	7	Power switch
Brown	DC_N	8	
Black	DRAIN	11	Grounding

2.5.1 How to set up NMEA0183 data output

Note: To set up data input from NMEA0183 equipment, see "NMEA0183 equipment data input" on page 2-6.

1. Tap the [Home] icon () to show the home screen and display mode settings.
2. Tap [Settings], then scroll the menu to show [Initial Setup]. Tap [Initial Setup].
3. Scroll the menu to show [NMEA0183 Output], then tap [NMEA0183 Output].
4. Tap [Baud Rate] to set the output baud rate. Available options are [4,800], [9,600] and [38,400].
5. Tap the appropriate setting then tap the  icon.
6. Tap [NMEA-0183 Version] to set the version. Available options are [1.5], [2.0] and [3.0].
7. Tap the appropriate setting then tap the  icon.
8. Select the appropriate sentences to output, then tap the flipswitch to set the sentence to [ON].
9. Tap the [Close] icon at the top right of the screen to close the menus.

2.6 DRS Radar Sensor Connections

The figures below show connection examples with radar sensors which are compatible with the TZT9F.

For details regarding connection and cables required for connection with the radar sensor, see the radar sensor's installation manual.

Connection examples for radome sensors

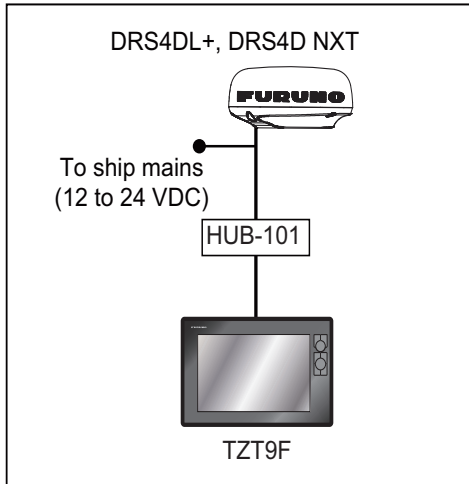

Connection examples for open-array sensors

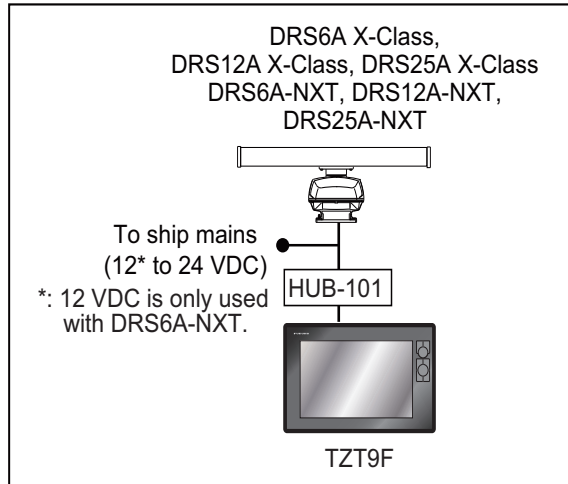

2.7 Network Connector

Like previous NavNet series equipment, the TZT9F may share radar and fish finder images, and other information, across an Ethernet connection. Up to six TZT9F units may be connected to the same network at one time. However, for configurations with one or more TZT2BB included, the maximum number of networked TZT9F units is four. TZT9F is equipped with a network connector (RJ45).

2.8 CAN bus (NMEA2000 Connector)

Every TZT9F has one CAN bus connector (micro style connector). All TZT9F must be connected to the same CAN bus backbone.

What is CAN bus?

CAN bus is a communication protocol (NMEA2000 compliant) that shares multiple data and signals through a single backbone cable. You can simply connect any CAN bus devices onto the backbone cable to expand your network on-board. With CAN bus, IDs are assigned to all the devices in the network, and the status of each sensor in the network can be detected. All the CAN bus devices can be incorporated into the NMEA2000 network. For detailed information about CAN bus wiring, see "FURUNO CAN bus Network Design Guide" (Type: TIE-00170).

2.8.1 How to connect the NavNet Tztouch3 to CAN bus equipment

Below is an example of two NavNet Tztouch3 units, connected via CAN bus to CAN bus sensors.

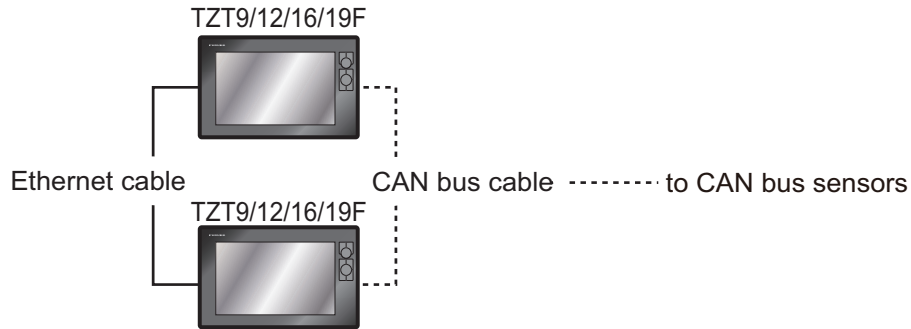

2.8.2 How to connect Yamaha engine(s)

When interfaced with Yamaha outboard engine(s) compatible with Command Link[®], Command Link Plus[®] and Helm Master[®], the TZT9F can display engine information on a dedicated Yamaha engine status display.

How to connect the engine

The TZT9F connects to the Yamaha engine network via the Yamaha Interface Unit. Arrange the Yamaha Interface Unit through a local Yamaha representative.

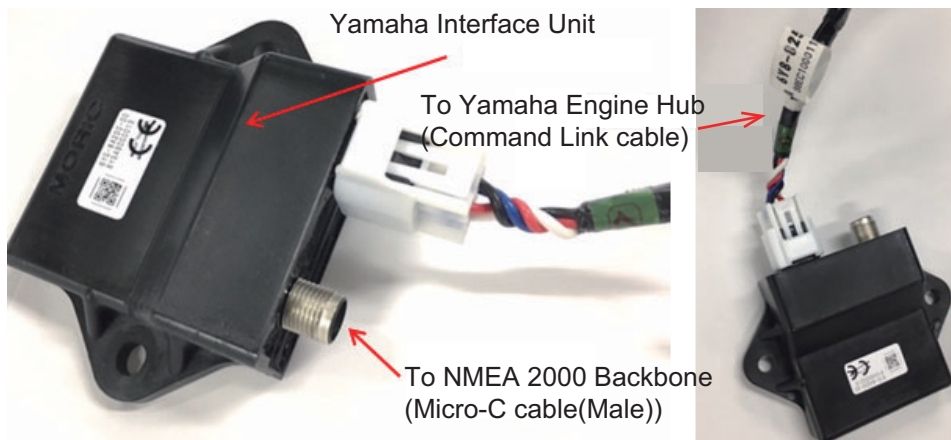

The Yamaha Engine Hub (Yamaha supply), which connects between the engine and the Yamaha Interface Unit, is also required.

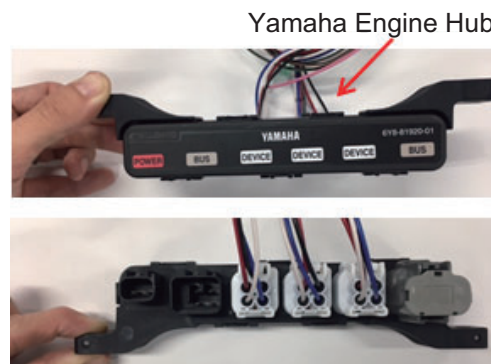

Connection to TZT9F

Connect the Yamaha Interface Unit to the Yamaha Engine Hub.

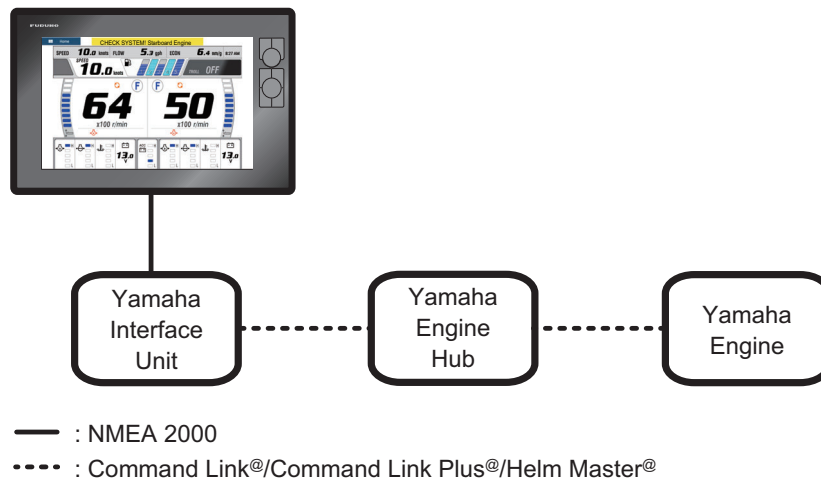

How to set up the engine display

Once the TZT9F detects the Yamaha engine network, the engine can be set up on [Settings]→[Initial Setup]→[YAMAHA ENGINE SETUP]. See section 3.3 for details.

2.8.3 NMEA0183 equipment data input

Note: To output NMEA0183 data, see paragraph 2.5.1.

To connect NMEA0183 equipment to TZT9F, use the CAN bus network via the optional NMEA data converter IF-NMEA2K2. This NMEA connection can accept a baud rate of 4800 or 38400.

Heading input to TZT9F allows functions such as Radar Overlay and course stabilization (North up, etc.) in the radar operating modes. The NMEA0183 heading refresh rate needs to be 100 ms in order for any radar function to work properly. NMEA0183 heading can be accepted on any CAN bus port at a baud rate up to 38400 bps.

Note 1: When using the ARPA function, set the heading refresh rate to 100 ms.

Note 2: For more information on connecting and wiring IF-NMEA2K2, refer to their respective installation manuals.

2.8.4 CAN bus (NMEA2000) input/output

Input PGN

PGN	Description
059392	ISO Acknowledgment
059904	ISO Request
060928	ISO Address Claim
126208	NMEA-Request Group Function
	NMEA-Command Group Function
	NMEA-Acknowledge Group Function
126992	System Time
126996	Product Information
127237	Heading/Track Control
127245	Rudder

PGN	Description
127250	Vessel Heading
127251	Rate of Turn
127257	Attitude
127258	Magnetic Variation
127488	Engine Parameters, Rapid Update
127489	Engine Parameters, Dynamic
127505	Fluid Level
128259	Speed
128267	Water Depth
129025	Position, Rapid Update
129026	COG & SOG, Rapid Update
129029	GNSS Position Data
129033	Local Time Offset
129038	AIS Class A Position Report
129039	AIS Class B Position Report
129040	AIS Class B Extended Position Report
129041	AIS Aids to Navigation (AtoN) Report
129291	Set & Drift, Rapid Update
129538	GNSS Control Status
129540	GNSS Satellites in View
129793	AIS UTC and Date Report
129794	AIS Class A Static and Voyage Related Data
129798	AIS SAR Aircraft Position Report
129801	AIS Addressed Safety Related Message
129802	AIS Safety Related Broadcast Message
129808	DSC Call Information
129809	AIS Class B "CS" Static Data Report, Part A
129810	AIS Class B "CS" Static Data Report, Part B
130306	Wind Data
130310	Environmental Parameters
130311	Environmental Parameters
130312	Temperature
130313	Humidity
130314	Actual Pressure
130316	Temperature, Extended Range
130577	Direction Data
130578	Vessel Speed Component

2. WIRING

Output PGN

The CAN bus output PGN setting (found under the [Initial Setup] menu) is global to the network. Note that only one TZT9F will output CAN bus data on the network at a time: the TZT9F which is powered ON first. If that display is turned OFF, another will take its place to output the data.

PGN	Description	Remarks	Output cycle (msec)
059392	ISO Acknowledgment	For Certification, Refusing output requirement	
059904	ISO Request	For Certification, Requiring output	
060928	ISO Address Claim	For Certification <ul style="list-style-type: none"> • Address autonomy • Receiving output requirement 	
126208	NMEA-Request group function	For Certification <ul style="list-style-type: none"> • Address autonomy • Receiving output requirement 	
	NMEA-Command group function	For Certification Changing the setting of other equipment	
	NMEA-Acknowledge group function	For Certification Sending the confirmation for NMEA-Request group function and NMEA-Command group function	
126464	PGN List-Transmit PGN's group function	For Certification Receiving output requirement	
	PGN List-Received PGN's group function	For Certification Receiving output requirement	
126992	System Time		1000
126993	Heartbeat		
126996	Product Information	For Certification Receiving output requirement	
127250	Vessel Heading		100
127251	Rate of Turn		100
127257	Attitude		1000
127258	Magnetic Variation		1000
128259	Speed		1000
128267	Water Depth		1000
128275	Distance Log		1000
129025	Position, Rapid Update		100
129026	COG & SOG, Rapid Update		250
129029	GNSS Position Data		1000
129033	Local Time Offset		1000
129283	Cross Track Error		1000
129284	Navigation Data		1000
129285	Navigation-Route/WP Information	<ul style="list-style-type: none"> • Outputs when waypoint is set/changed (own ship's position is required) • Outputs when receiving ISO request 	
130306	Wind Data		100
130310	Environmental Parameters		500
130312	Temperature		2000
130313	Humidity	Outputs when receiving the ISO request	
130314	Actual Pressure		2000
130316	Temp., Extended Range		2000

2.9 Transducer (Option)

The Matching Box MB-1100 is required when connecting a 1kW transducer to TZT9F. See the interconnection diagram for transducer connection.

All other transducers are connected to the TZT9F directly.

2.10 Example TZT9F System Configurations

Small vessels (internal GPS, internal fish finder, DRS4DL, DRS4DL+)

The example below shows a typical configuration for small vessels.

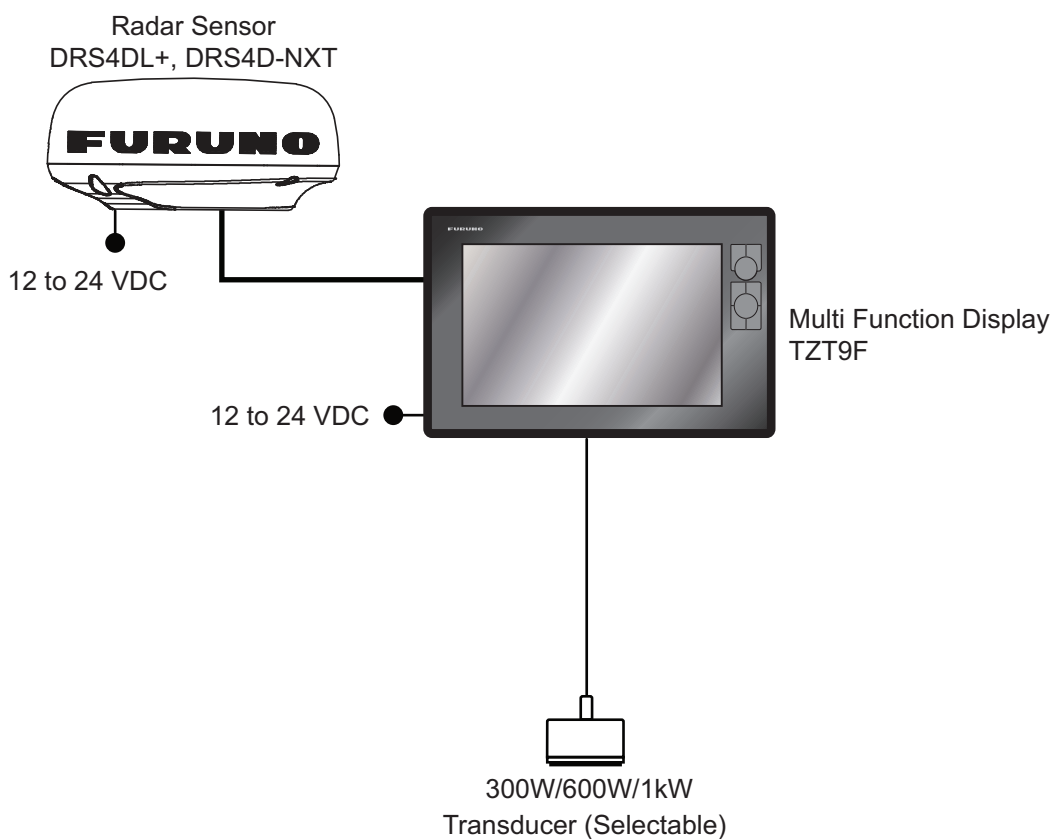

Note: Matching Box MB-1100 (optional supply) is required for some FURUNO transducers. See the INTERCONNECTION DIAGRAM at the back of this manual.

2. WIRING

Mid/Large-size vessels (external GPS, fish finder, radar)

This is a single station plotter/radar/fish finder installation.
Refer to "SYSTEM CONFIGURATION" on page ii for more details.

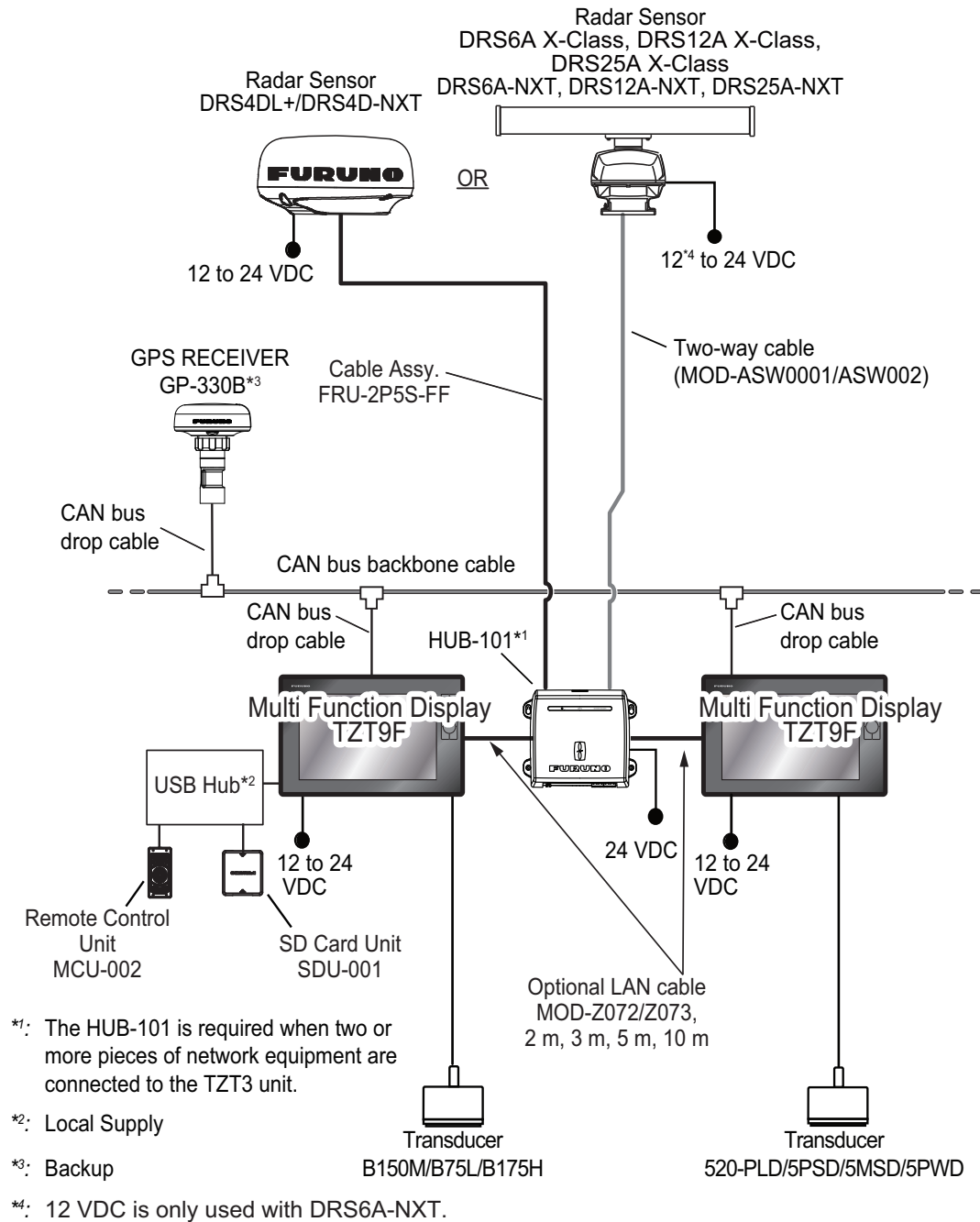



3. HOW TO SET UP THE EQUIPMENT

This chapter shows you how to set up your system according to the equipment you have connected.

Touch control description

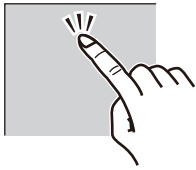
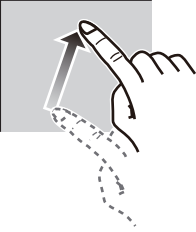
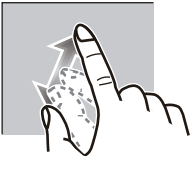
The touch control depends on the screen type. The basic operations to use during the installation setup are in the following table.

	Operating by a finger	Function
Tap		<ul style="list-style-type: none">• Select a menu item.• Select a setting option where there are multiple options.• Select an object.• Display the pop-up menu where available.
Drag		<ul style="list-style-type: none">• Scroll the menu.
Pinch	 Zoom in  Zoom out	Change the fish finder, plotter and radar range.

3. HOW TO SET UP THE EQUIPMENT

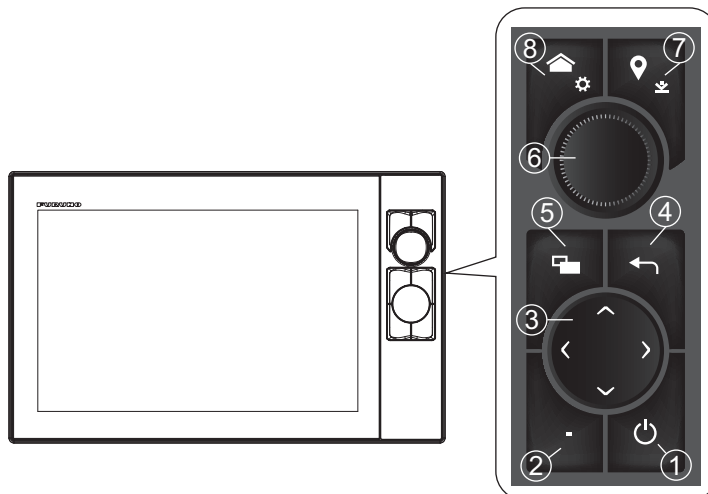

Control description



No.	Item	Function
1	✓ (Power switch)	<ul style="list-style-type: none"> • Short push: Turns the power on. With the unit powered, the [Quick Access] window appears. <u>[Quick Access] window</u> <ul style="list-style-type: none"> • Toggles radar, fish finder, multibeam sonar, NavPilot between transmit and stand-by. • Adjust the brilliance and hue of the display. • Turns the power off (device or network). • Locks, unlocks the touchscreen.
2	FUNC key	<ul style="list-style-type: none"> • Short push: Does the task assigned to the “two finger tap function” • Long push: Does the task assigned to the “two finger long tap function”
3	CursorPad	Moves the cursor.
4	Center/ESC key	<ul style="list-style-type: none"> • Centers own ship icon. • Returns to previous menu. • Undoes current operation.
5	Display Switching key	<ul style="list-style-type: none"> • Short push: Switches the active display in two-screen display. • Long push: Switches the active two-screen display into full screen display. Long push again to restore the two-screen display.
6	RotoKey™	<ul style="list-style-type: none"> • Push: Selects cursor position (pop-up menu appears). Also, confirms selected item. • Rotate: Selects the range on the fish finder, plotter and radar displays. Also, selects menu items.
7	Event/MOB key	<ul style="list-style-type: none"> • Short push: Inscribes an event mark. • Long push: Inscribes a MOB mark.
8	Home key	<ul style="list-style-type: none"> • Short push: Opens the home screen. • Long push: Opens the [Settings] menu.

How to operate the menus

The following procedure shows how to use the menu system.



1. Tap  (power switch) to turn the power on.
2. After the startup process completes, the last used display appears and a warning message is displayed. After reading the message, tap [OK].
3. Tap the [Home] icon () to show the home screen and display mode settings.

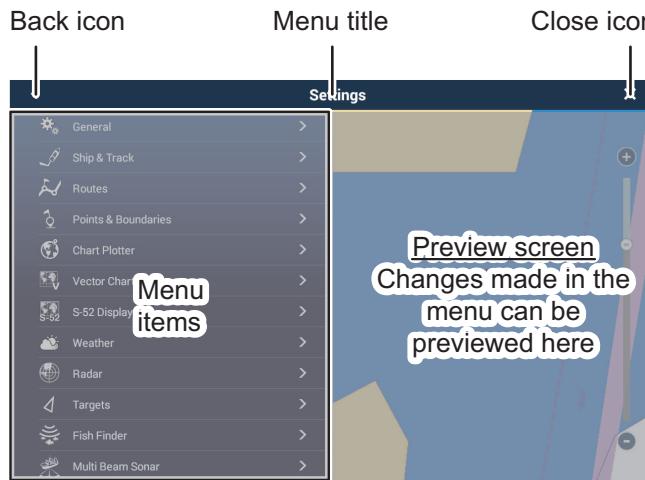

4. Tap [Settings] to open the [Settings] menu.
5. Scroll the menu to show [Initial Setup], then tap [Initial Setup].



6. Depending on the menu item selected, the following operations are available:

- ON/OFF flipswitch.  Tap to switch between [ON] and [OFF] to activate or deactivate the function.
- Slidebar and keyboard icon.  Drag the slidebar to adjust the setting. Settings may also be adjusted using the software keyboard for direct input.
- Keyboard icon.  Referring to the figure on the following page, use the software keyboard to input alphabet or numeric characters.

7. Tap [Close] (Indicated as an “X”) at the top right-hand side of the screen to exit.

3. HOW TO SET UP THE EQUIPMENT

How to use the software keyboard

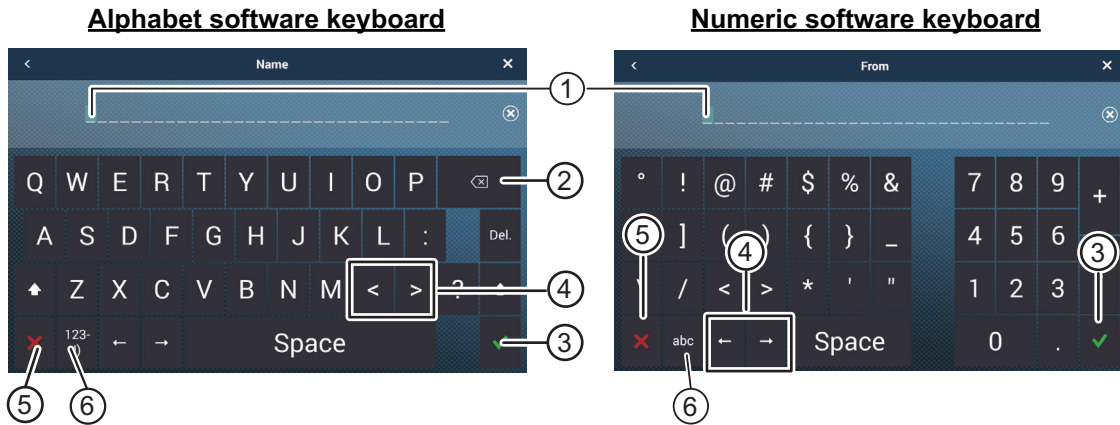

No.	Description
1	Cursor position is highlighted.
2	Backspace/Delete. Tap to erase one character at a time.
3	Enter button. Tap to complete character input and apply changes.
4	Cursor keys. Tap to move the cursor left/right.
5	Cancel button. Aborts character entry. No changes are applied.
6	Tap to switch between alphabet and numeric keyboards (where available).

3.1 How to Set Time Zone, Time Format and Language

Before setting up your equipment, select the time zone, language and units to use on your equipment as shown below.

1. Tap the [Home] icon to show the home screen and display mode settings.
2. Tap [Settings] to show the [Settings] menu.
3. Tap [General] to show the [General] menu.
4. Tap [Local Time Offset], and a numerical keyboard appears.
5. Input the time difference (using 15-minute intervals), then tap [✓].
6. Tap [Time Format] to show its option window.
7. Select how to display time, in 12- or 24-hour format. [Auto] automatically inserts AM, PM indication in 24-hour clock, when the language is English.
8. Tap the [<] at the top left of the screen to return to the [General] menu.

9. Tap [Language] to show the [Language] menu.

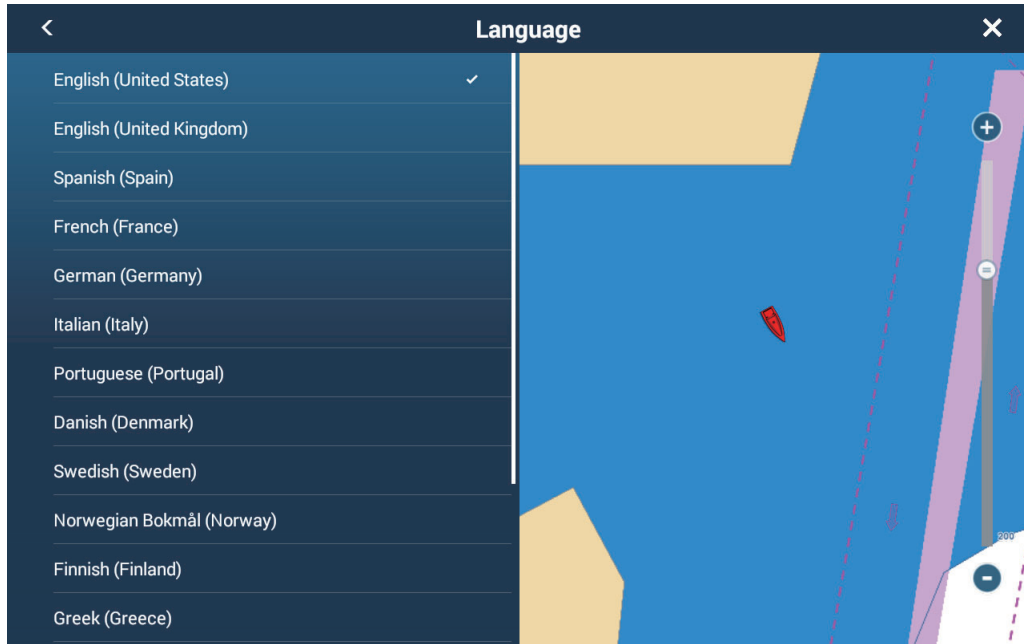

10. Tap the appropriate language to use. The unit will display a confirmation message. Tap [OK] to restart the unit and apply the new language settings. This process takes approximately five minutes to optimize the system for the new language setting. When the process is completed (five minutes later), the system restarts automatically.

3.2 How to Set Units of Measurement

1. Tap the [Home] icon to show the home screen and display mode settings.
2. Tap [Settings] to show the [Settings] menu.
3. Scroll the main menu to display [Units], then tap [Units].
4. Referring to the table below, set the units to show on the display.

Menu item	Description	Options
[Bearing Display]	Adjust the bearing display format.	[Magnetic], [True]
[True Wind Calculation Reference]	Set the reference for calculating true wind speed/angle.	[Ground], [Surface]
[Position Format]	Set the display format for position (Latitude/Longitude).	[DDD°MM.mmmm'], [DDD°MM.mmm'], [DDD°MM.mm'], [DDD°MM'SS.ss"], [DDD.dddddd°], [Loran-C], [MGRS]
[Loran C Station & GRI]	Available when [Position Format] is selected to [Loran-C].	Set Loran C station and GRI combination.
[Short/Long Change Over]	Set the distance at which to change between short and long range.	[0.0] to [2.0] (NM)
[Range (Long)]	Set the unit of measurement for long distances.	[Nautical Mile], [Kilometer], [Mile]
[Range (Short)]	Set the unit of measurement for short distances.	[Foot], [Meter], [Yard]
[Depth]	Set the unit of measurement for depth.	[Foot], [Meter], [Fathom], [Passi Braza]
[Height/Length]	Set the unit of measurement for height and length.	[Foot], [Meter]
[Fish Size]	Set the unit of measurement for fish sizes.	[Inch], [Centimeter]
[Temperature]	Set the unit of measurement for temperature.	[Fahrenheit Degree], [Celsius Degree]
[Boat Speed]	Set the unit of measurement for boat speed.	[Knot], [Kilometer per Hour], [Mile per Hour], [Meter per Second]
[Wind Speed]	Set the unit of measurement for wind speed.	[Knot], [Kilometer per Hour], [Mile per Hour], [Meter per Second]
[Atmospheric Pressure]	Set the unit of measurement for atmospheric pressure.	[HectoPascal], [Millibar], [Millimeter of Mercury], [Inch of Mercury]
[Oil Pressure]	Set the unit of measurement for oil pressure.	[KiloPascal], [Bar], [Pound per Square Inch]
[Volume]	Set the unit of measurement for tank volume.	[Gallon] (Gallon & Gallon/hour), [Litre] (Litre & Litre/hour)
[Reset Default Settings]	Restore default unit settings.	[OK], [Cancel]

3.3 Initial Setup

This section shows you how to set your system according to the sensors you have connected.

Note: Some units are set to metric in this section, actual setting ranges vary depending on the unit of measurement set in the [Units] menu.

1. Tap the [Home] icon to show the home screen and display mode settings.
2. Tap [Settings] to show the [Settings] menu.
3. Scroll the main menu, then tap [Initial Setup] to show the [Initial Setup] menu.
4. Referring to the tables on the following pages, set your equipment.

[Initial Setup] menu - [GPS POSITION]

Menu item	Description	Options (setting range)
[Longitudinal (from bow)]	Referring to the figure on the right, enter the GPS antenna positioning bow-stern (Longitudinal) and port-starboard (Lateral) position from the origin.	0 (m) to 999 (m)
[Lateral (-Port)]		-99 (m) to +99 (m) Port-side is negative, Starboard-side is positive.



Menu item	Description	Options (setting range)
[Boat Length]	Set the length of your boat.	0 (m) to 999 (m)
[Own Ship MMSI]	Set the MMSI for your boat (used for fleet tracking function only).	
[Own Ship Name]	Set the name for your boat (used for fleet tracking function only).	
[Size of Static Icon]	Set the size of static (such as own ship) icons.	50 to 150
[Depth Display]	Select the start point for depth measurement.	[Under Keel], [Under Sea Level]
[External Transducer Draft]	Set the draft of external transducer. See the instructions below for how to set the draft of other types of transducers. For internal/network transducers , set the draft from Home screen→[Settings]→[Sounder]→[Transducer Draft]. For multi-beam sonars , set the draft from Home screen→[Settings]→[Multi-beam Sonar]→[Initial Setup]→[External Transducer Draft].	0.0 (m) to 99.9 (m)
[Keel Draft]	Set the keel draft.	0.0 (m) to 99.9 (m)

Engine & Tank. Instruments Setup

Menu item	Description	Options (setting range)
[Engine & Tank Automatic Setup]	See "[Initial Setup] menu - [Engine & Tank Automatic Setup]" on page 3-12.	
[Engine & Tank Manual Setup]	See "[Initial Setup] menu - [Engine & Tank Automatic Setup]" on page 3-12.	
[Graphic Instruments Setup]	See "[Initial Setup] menu - [GRAPHIC INSTRUMENTS SETUP]" on page 3-11.	

3. HOW TO SET UP THE EQUIPMENT

[HOME] Screen Setup

Menu item	Description	Options (setting range)
[Restore Default Settings]	Click [OK] to restore the [HOME] screen's default settings.	

Manual Fuel Management Setup

Menu item	Description	Options (setting range)
[Total Fuel Capacity]	Enter the total fuel capacity of your tank(s).	0 to 9,999(L).
[Manual Fuel Management]	Set to [ON] for manual fuel management. See the Operator's Manual.	[OFF], [ON].

[Initial Setup] menu - [YAMAHA ENGINE SETUP]

Menu item	Description	Options (setting range)
[Trip & Maintenance]	Reset fuel used, trip distance, engine trip and maintenance hours (trip hour, standard hour, optional hour, total hour).	[Trip Fuel & Distance]: [Fuel Used], [Trip Distance]. [Trip & Maintenance Hours]: [Port], [Starboard].
[Trim Level Calibration]	Trim all engines to fully down position (zero). If trim level is not zero, tap [SET] to set trim level to zero.	–
[Fuel Flow Calibration]	If the fuel flow indication (gph=gallons per hour) is wrong, you can calibrate the indication to show correct flow. Enter a negative value if the indication is higher than actual; a positive value if the indication is lower than actual.	-7 to +7
[Engine Interface Software Ver. & ID]	Display engine interface software version and ID.	–
[Reset Engine Interface]	Reset engine interface.	–
[Reset Engine Instance]	Reset engine instance.	–
[Reset Number of Engines]	Enter number of engines.	[1], [2], [3], [4], [4P], [4S]
[Trouble Codes]	Display trouble codes. For Yamaha engine trouble codes, see the manual for the Yamaha engine.	–

[Initial Setup] menu - [IF-NMEAFI SETUP]

Menu item	Description	Options (setting range)
[Select IF]	Select [IF-NMEAFI] to set the analog data that is input from the IF-NMEAFI. The setting is made after restarting the IF-NMEAFI.	
[Category]	Select the use (category) for this sensor.	[Wind], [ST800_850], [Fuel], [FreshWater], [WasteWater], [LiveWell], [Oil], [BlackWater]
[Resistance Full]	The resistance, in Ohms, when the tank is full.	[0] (ohm) to [500] (ohm)
[Resistance Mid]	The resistance, in Ohms, when the tank is half full.	[0] (ohm) to [500] (ohm)
[Resistance Empty]	The resistance, in Ohms, when the tank is empty.	[0] (ohm) to [500] (ohm)
[Capacity]	The capacity of the tank.	[0] (G) to [2650] (G)

Menu item	Description	Options (setting range)
[Fluid Instance]	Select the NMEA instance for the tank.	[000] to [254]
[Self test]	Test results are displayed.	
[Set Hardware to Factory Default]	Resets the converter selected at [Select IF] to factory default.	[OK], [Cancel]

[Initial Setup] menu - [DATA ACQUISITION]

Menu Item	Description	Options (setting range)
[GP330B WAAS Mode]	Select [ON] to use the WAAS mode for the corresponding GPS antenna.	[ON], [OFF]
[WS200 WAAS Mode]		
[Data Source]	Select the source for each data to input to the system. If two or more sources are connected for a data, select one using the pull-down dialog box. The FURUNO products are shown at the upper part of the list.	
[Sensor List]	Show the information for sensors connected to your equipment. Also, you can set "Nickname" for them here.	
[NMEA0183 Output] Note: If the TTM sentence is received at the same time as another sentence, the constraints to communication bandwidth may cause a decrease in the number of TTM targets.	[Port Configuration] - [Baud Rate]: Select the output baud rate.	[4,800], [9,600], [38,400]
	[Port Configuration] - [NMEA-0183 Version]: Select the NMEA0183 version for output.	[1.5], [2.0], [3.0]
	[Sentences]: Select the sentences to output.	[ON], [OFF]
[NMEA2000 PGN Output]	Select [ON] for the PGN's (Parameter Group Number, CAN bus (NMEA2000) message) to output from the CAN bus port.	
[Sky View]	Show the condition of GPS and GEO (WAAS) satellites. Number, bearing and elevation angle of all GPS and GEO satellites (if applicable) in view of your GPS receiver appear.	

[Initial Setup] menu - [NMEA2000 LOG]

Menu Item	Description	Options (setting range)
[Enable NMEA2000 Log]	Set to [ON] when using NMEA2000 log.	[ON], [OFF]
[NMEA2000 Log Storage Location]	Show the location where to store the log.	

[Initial Setup] menu - [INTERNAL GPS SETUP]

Menu Item	Description	Options (setting range)
[WAAS Mode]	Set to [ON] to use the WAAS mode.	[ON], [OFF]

[Initial Setup] menu - [SC-30 SETUP]

This menu is only available with SC-30 connection.

Menu item	Description	Options (setting range)
[WAAS Mode]	Select [ON] to use the WAAS mode.	[ON], [OFF]
[Heading Offset]	Enter the offset value for heading.	-180° to +180°
[Pitch Offset]	Enter the offset value for pitching.	-90° to +90°
[Roll Offset]	Enter the offset value for rolling.	-90° to +90°

3. HOW TO SET UP THE EQUIPMENT

[Initial Setup] menu - [NETWORK SENSOR SETUP]

The [NETWORK SENSOR SETUP] section allows you to set up compatible FURUNO NMEA2000 sensors. Calibrations and offsets applied in this menu are also applied to the sensor itself.

Tap the sensor to access its menus and settings. For details regarding the menu structure and set up of each sensor, see the operator's manual supplied with the sensor.

[Initial Setup] menu - [CALIBRATION]

Menu item	Description	Options (setting range)
[Heading]	Offset heading data.	-180.0° to +180.0°
[Speed Through Water]	Calibrate speed data. Enter amount in percentage.	-50% to +50%
[Wind Speed]	Offset wind speed data. Enter amount in percentage.	-50% to +50%
[Wind Angle]	Offset wind angle data.	-180° to +180°
[Sea Surface Temperature]	Offset sea surface temperature data.	-10°C to +10 °C

[Initial Setup] menu - [DATA DAMPING]

Menu item	Description	Options (setting range)
[COG & SOG]	Set data damping time. The lower the setting the faster the response to change.	0 to 59 (seconds)
[Heading]		
[Speed Through Water]		
[Wind Speed & Angle]		
[Rate of Turn]		

[Initial Setup] menu - [FUSION]

Menu item	Description	Options (setting range)
[Connect to Fusion]	Connects to your Fusion equipment.	
[Fusion Auto Volume]	Set to [ON] to allow the TZT9F to control the FUSION volume. Volume is adjusted according to vessel speed.	[ON], [OFF]
[Minimum Speed]	Set the minimum speed threshold. Exceeding this speed activates volume auto control.	0.0 (kn) to 98.9 (kn)
[Maximum Speed]	Set the maximum speed threshold.	0.1 (kn) to 99.0 (kn)
[Volume Increase]	Set the amount of extra volume to output when the vessel reaches the [Maximum Speed] setting.	10% to 50%

[Initial Setup] menu - [BROWSER INSTALLATION]

Menu item	Description	Option (setting range)
[FAX30 Browser]	Show the Facsimile Receiver FAX-30 display.	
[FA30 Browser]	Show the AIS Receiver FA-30 display.	
[FA50 Browser]	Show the AIS Receiver FA-50 display.	

[Initial Setup] menu (Other menu items)

Menu item	Description	Option (setting range)
[Chart Master Device]	Set to [ON] to use this unit as the master, [OFF] to use this unit as a slave.	
[System ID]	The system ID for this device within the network.	
[IP Address]	IP address for this unit within the network.	
[Quick Self Test]	Displays various details regarding the TZT9F, radar and fish finder.	
[Certification Mark]	Displays relevant certification for this equipment.	
[Service]	Requires login password. For the service technician.	
[Update Network Equipments]	For the service technician.	
[Event Input Configuration]	Set the function for the event switch.	[OFF], [Event Mark], [MOB], [Ferry]
[Remote Controller Configuration]	When there are multiple units in the NavNet network, the Remote Controller MCU-004/MCU-005 can select the display to show on the unit with MCU-004/MCU-005 connection. Further, the cycling order of displays can be set. See the Operator's Manual.	
[Sirius Radio Diagnostic]	Check the satellite radio of the FURUNO BBWX SiriusXM weather receiver for proper operation. See the Operator's Manual.	
[Sirius Weather Diagnostic]	Check the weather section of the FURUNO BBWX SiriusXM weather receiver for proper operation. See the Operator's Manual.	
[Reset Default Settings]	Reset the system to default settings.	[OK], [Cancel]

[Initial Setup] menu - [GRAPHIC INSTRUMENTS SETUP]

Menu Item	Description	Options (setting range)
[Maximum Boat Speed]	Set the transducer's maximum detectable speed.	1 (kn) to 99 (kn)
[Maximum Wind Speed]	Set the transducer's maximum detectable speed.	1 (kn) to 99 (kn)

[GRAPHIC INSTRUMENTS SETUP] - [DEPTH]

Menu Item	Description	Options (setting range)
[Minimum Depth]	Set the transducer's minimum detectable depth.	1 (m) to 1999 (m)
[Maximum Depth]	Set the transducer's maximum detectable depth.	1 (m) to 2000 (m)

[GRAPHIC INSTRUMENTS SETUP] - [SEA SURFACE TEMPERATURE]

Menu Item	Description	Options (setting range)
[Minimum Sea Surface Temperature]	Set the transducer's minimum detectable temperature.	0.00°C to 98.99°C
[Maximum Sea Surface Temperature]	Set the transducer's maximum detectable temperature.	0.01°C to 99.99°C

3. HOW TO SET UP THE EQUIPMENT

[GRAPHIC INSTRUMENT SETUP] - [PROPULSION ENGINE] or [OTHER ENGINE]

Menu Item	Description	Options (setting range)
[Max. RPM]	Set the maximum rpm of your engine to show on the RPM display.	1 (rpm) to 20,000 (rpm)
[Red Zone Oil Pressure]	Set the starting value for the red zone area of the oil pressure meter.	0 (psi) to 143 (psi)
[Max. Oil Pressure]	Set the maximum oil pressure of your engine.	1 (psi) to 144 (psi)
[Min. Temperature]	Set the minimum temperature for your engine.	0.00°C to 99.00°C
[Red Zone Temperature]	Set the starting value for the red zone area of the engine temperature indicator.	0.01°C to 999.00°C

CZone

Menu item	Description
[Add Default CZone Pages]	Create, edit CZone pages.
[CZone DIP Switch Settings]	Set this unit's DIP switches. For the serviceman. Do not change the settings.

Menu item	Description
[Reset Instrument Pages]	Resets all instrument pages to default. [OK], [Cancel]
[Reset Default Settings]	Resets applicable settings to default. [OK], [Cancel]

[Initial Setup] menu - [Engine & Tank Automatic Setup]

The TZT9F will automatically detect engines and tanks connected to the same network. This is the recommended method for setting up engines and tanks.

[Initial Setup] menu - [Engine & Tank Manual Setup]

The manual set up method should only be used if the automatic setup did not correctly detect your engines or tanks.

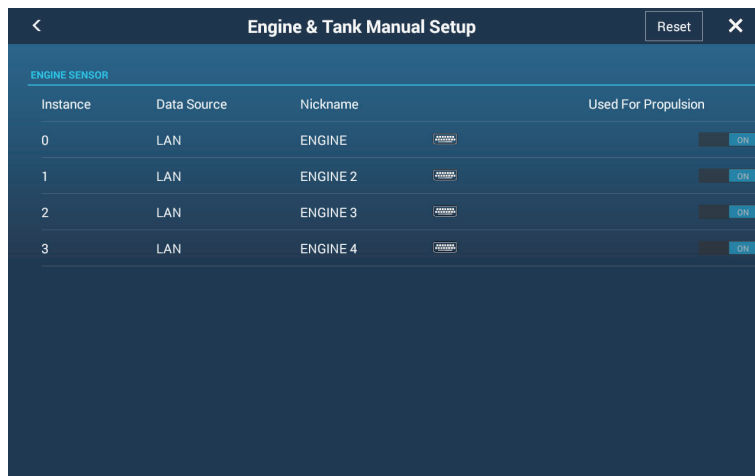

Menu Item	Description	Options (setting range)
[Nickname]	Change the nickname for the engine or tank.	
[Used For Propulsion]	Select which engine/tank is used to calculate the distance which may be traveled using the remaining fuel. [ON] uses the engine/tank for calculations, [OFF] ignores the engine/tank.	[ON], [OFF]
[Reset]	Resets the engine/tank details to default.	

3.4 How to Set Up the Radar

1. Tap the [Home] icon to show the home screen and display mode settings.
2. Tap [Radar] from the [Settings] menu.
3. Tap [Radar Source], then select the appropriate radar sensor.

Note: If a DRS sensor is connected but does not appear in the [Radar Source] list, close the list and open it again. The name of the DRS sensor should appear with a check mark, as in the example below.



4. Scroll the [Radar] menu display the menu item [Radar Initial Setup], then tap [Radar Initial Setup].
5. Referring to the tables which follow, set up the radar.

[Radar] menu - [Radar Initial Setup]

Menu item	Description	Options (setting range)
[Antenna Rotation]	Select the speed of antenna rotation. Not available (greyed out) with the radar sensor DRS4DL, DRS4DL+.	[Auto], [24 RPM]
[Antenna Heading Align]	See "How to align the antenna heading" on page 3-15.	[-179.9°] to [+180.0°]
[Main Bang Suppression]	If main bang appears at the screen center, slide the circle icon so that the main bang disappears, while watching the radar echo at the left-hand side of the display.	[0] to [100]
[Enable Sector Blanking]	Up to two sectors may be selected for blanking (no transmission). Select [ON] to enable this feature. Set the start and end angles (0° to 359°).	[ON], [OFF]
[Enable Sector 2 Blanking]		

[Radar] menu - [Antenna Position]

Menu item	Description	Options (setting range)
[Longitudinal (from bow)]	Referring to the figure on the right, enter the radar antenna positioning bow-stern (Longitudinal) and port-starboard (Lateral) position from the origin.	[0] m to [999] m
[Lateral (-Port)]		[-99] m to [+99] m Port-side is negative, Starboard-side is positive.



3. HOW TO SET UP THE EQUIPMENT

Menu item	Description	Options (setting range)
[Antenna Height]	Select the height of the antenna above the waterline. Not available (greyed out) with the radar sensor DRS4DL, DRS4DL+.	[Under 3m], [3m-10m], [Over 10m]
[Auto Tuning]	Enable/disable auto tuning for the connected radar. Not available (greyed out) with the radar sensor DRS4D-NXT.	[ON], [OFF]
[Tuning Source]	Select a display in the dual range display to manually tune. Not available (greyed out) with the radar sensor DRS4D-NXT, DRS4DL, DRS4DL+.	[Range1], [Range2]
[Manual Tuning]	Manually tune the radar. Not available when [Auto Tuning] is enabled or the radar sensor DRS4D-NXT is used.	[-50] to [50]
[Radar Monitoring]	Display various information regarding the connected radar.	
[Radar Optimization]	Automatically adjust magnetron output and tuning for the connected radar. Available when the [TX/STBY] setting is [ON]. Do not change these settings. Not available (greyed out) with the radar sensor DRS4D-NXT. Note 1: For the service technician only. Note 2: The service technician performs this whenever the magnetron is replaced.	
[ARPA Advanced Settings]	For the service technician only. Do not change these settings. This item is available when [TX/STBY] is [ON]. Not available (greyed out) with the radar sensor DRS4DL, FAR-2xx7 series radar antenna.	
[TX Channel]	Select [1], [2] or [3], the channel where the interference is smallest. See the operator's manual for details. Available with the radar sensor DRS4D-NXT.	[Auto], [1], [2], [3]
[Target Analyzer Mode]	You can emphasize rain clutter or target echoes when the target analyzer is active. Select [Rain] or [Target] as appropriate. See the operator's manual for details. Available with the radar sensor DRS4D-NXT, DRS6A-NXT and DRS12A-NXT.	[Rain], [Target]
[Auto acquire by Doppler]	When selecting [ON], approaching targets (ships, rain clutter, etc.) within 3 NM from own ship are automatically acquired by the Doppler calculated from the radar echo. See the operator's manual for details. Available with the radar sensor DRS4D-NXT, DRS6A-NXT and DRS12A-NXT.	[ON], [OFF]
[Set Hardware to Factory Default]	Resets the radar selected at [Radar Source] to factory default.	[OK], [Cancel]
[Reset Default Settings]	Resets [Radar] menu settings to default.	[OK], [Cancel]

How to align the antenna heading

You have mounted the antenna unit facing straight ahead in the direction of the bow. Therefore, a small but conspicuous target dead ahead visually should appear on the heading line (zero degrees).

In practice, you will probably observe some small bearing error on the display because of the difficulty in achieving accurate initial positioning of the antenna unit. The following adjustment will compensate for the error.

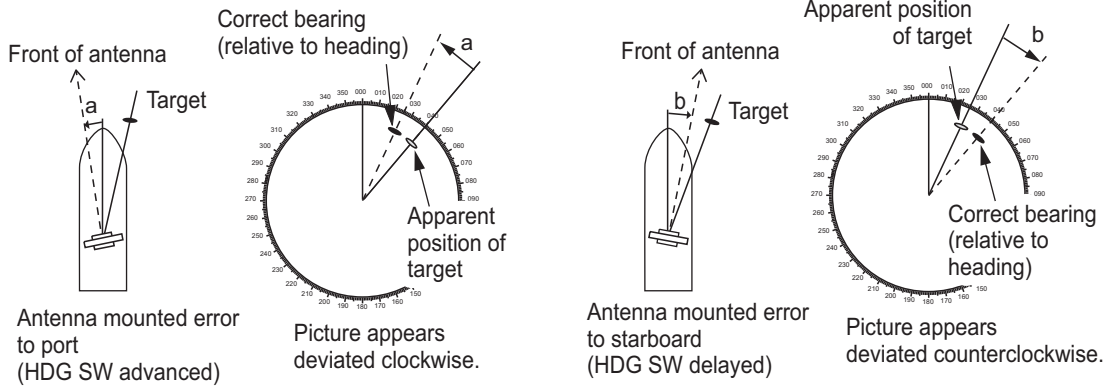

1. Set your radar with 0.125 and 0.25 nm range and the head up mode. You can select a range by using the pinch action. The range appears at the bottom right of the screen. Range may also be selected using the slide bar displayed on the right-hand side of the radar display area. Drag the bar up to zoom in, or down to zoom out.

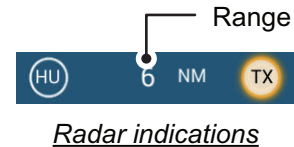
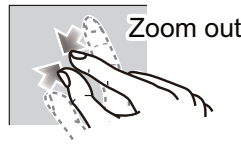
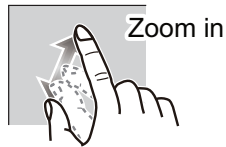

Radar indications

2. Turn the vessel's bow toward a target.
3. Tap the [Home] icon to show the home screen and display mode settings.
4. Tap [Radar] to show the [Radar] menu.
5. Tap [Antenna Heading Align].
6. Key in an offset value (setting range: -179.9° to $+180^{\circ}$) that puts the target at the very top of the screen, then tap the icon.
 - + : rotate echo in clockwise direction
 - : rotate echo in counterclockwise direction
7. Confirm that the target echo is displayed at correct bearing on the screen.

3.5 How to Set Up the Sounder

If you have an internal sounder or BBDS1 or DFF series, set up the sounder as shown in this section.

Note 1: Some menu items are restricted to certain external depth sounders and that some menu items may not be available when using the internal depth sounder.

Note 2: For DFF-3D setup instructions, see the DFF-3D operator's manual.

1. Tap the [Home] icon to show the home screen and display mode settings.
2. Tap [Settings].
3. Scroll the [Settings] menu to display [Fish Finder], then tap [Fish Finder].
4. Scroll the [Fish Finder] menu to display the [FISH FINDER INITIAL SETUP] menu.

Fish Finder Initial Setup menu

Menu item	Description	Options (setting range)
[Zero Line Rejection]	When you turn the zero line (transmission line) rejection on, the line is not shown, which allows you to see fish echoes near the surface. The width of the line changes with the transducer used and installation characteristics. If the width of the line is 1.4 m or more, select [ON]. Note: When you select [DFF3] or [DI-FFAMP] on [Fish Finder Source] menu and select [ON], adjust the width of the zero line on [Zero Line Range].	[ON], [OFF]
[Zero Line Range]	Adjust the width of the zero line. Note: DFF3 only, all other transducer models are fixed at 2.0 m.	[1.4] to [2.5]
[Transducer Draft]	Set the distance between the transducer and the draft line to show the distance from the sea surface.	[0.0m] to [99.9m]
[Salt Water]	Select [ON] if you use this equipment in salt water.	[ON], [OFF]
[Fish Finder Source]	Select the sounder used. Note: Where the TZT9F's nickname has been changed in [INITIAL SETUP] → [SENSOR LIST], the [Fish Finder Source] option reflects the name change.	[TZT9F], [DFF1/BBDS1], [DFF3], [DFF1-UHD]
[Preset Frequency Setup (DI-FFAMP)]	This menu item is available when a CHIRP compatible transducer is connected. There is a limit to the setting for each transducer. Note: The TZT9F is NOT compatible with the DI-FFAMP. However, this menu can be used when a compatible CHIRP transducer is used.	[Preset Frequency 1 Setup], [Preset Frequency 2 Setup], [Preset-Frequency 3 Setup]
[Transducer Setup]	Setup Transducer and Motion Sensor. See "Transducer Setup menu" on page 3-18.	
[Transmission Power Mode]	Set the TX power level. See the operator's manual for details. Note: For DFF1-UHD users, the settings are as follows: [Off], [Min], [Auto]. The default setting is set [Auto].	[Max], [Min]
[External KP]	Select on to synchronize with external sounder's keying pulse.	[ON], [OFF]

Menu item	Description	Options (setting range)
[Bottom Level HF] [Bottom Level LF]	The default bottom level setting (0) determines that two strong echoes received in sequence are bottom echoes. If the depth indication is not stable in the default setting, adjust the bottom level here. If vertical lines appear from the bottom echo in the bottom lock display, lower the bottom level to erase the vertical lines. If you can not identify the fish near the bottom from the bottom echo, increase the bottom level.	[-40] to [40]
[Gain Offset HF] [Gain Offset LF]	If the gain setting is wrong, or there is a difference in the gain between the low and high frequencies, you can balance the gain for the two frequencies here.	[-50] to [50]
[Auto Gain Offset HF] [Auto Gain Offset LF]	If the auto gain offset is wrong, or there is a difference in the gain between the low and high frequencies, set an offset here to balance auto gain for the two frequencies.	[-5] to [5]
[STC HF] [STC LF]	Adjust the low (LF) or high (HF) STC frequency. See the operator's manual for details. Note: This menu item is available only for DFF3 and DFF1-UHD users.	[0] to [10]
[Frequency Adjust HF] [Frequency Adjust LF]	Adjust the low (LF) or high (HF) frequency to remove interference caused by other fish finders operating on the same frequency as your fish finder. See the operator's manual for details. Note: This menu item is available only for DFF3 users.	[-50] to [50]
[TX Pulse HF] [TX Pulse LF]	The pulse length is automatically set according to range and shift, however it can also be set manually.. Use a short pulse for better resolution and a long pulse when detection range is important. To improve resolution on zoom displays, use [Short 1] or [Short 2]. <ul style="list-style-type: none"> • [Short 1] improves the detection resolution, but the detection range is shorter than with [Std] (pulse length is 1/4 of [Std]). • [Short 2] raises the detection resolution, however detection range is shorter (pulse length is about 1/2 of [Std]) than [Std]. • [Std] is the standard pulse length, and is suitable for general use. • [Long] increases the detection range but lowers the resolution (about 1/2 compared to the [Std] pulse length) Note: This menu item is available only for DFF3 users.	[Short1], [Short2], [Standard], [Long]
[RX Band HF] [RX Band LF]	Set the bandwidth for low (LF) or high (HF) frequency. The RX bandwidth is automatically set according to pulse length. To decrease noise, select [Narrow]. For better resolution, select [Wide]. Note: This menu item available only for DFF3 users.	[Narrow], [Standard], [Wide]
[Temperature Port]	Set the data source for water temperature. <ul style="list-style-type: none"> • [MJ Port]: Use the temperature/speed sensor for data. • [Low Frequency]: Use the LF sensor for data. • [High Frequency]: Use the HF sensor for data. Note: Available only for DFF3 and DFF1-UHD users.	[MJ Port], [Low Frequency], [High Frequency]

3. HOW TO SET UP THE EQUIPMENT

Menu item	Description	Options (setting range)
[Fish Finder Demo Mode]	Enable or disable the demonstration mode for the sounder. <ul style="list-style-type: none"> [OFF]: Disable the demo mode. [Shallow]: Enable shallow water demo mode. [Deep]: Enable deep water demo mode. Note: For internal fish finder users, the settings are as follows: [Off], [Demo1] to [Demo4].	[OFF], [Shallow], [Deep]
[Set Hardware to Factory Default]	Reset the external fish finder to its factory default settings.	[OK], [Cancel]
[Restore Default Settings]	Restore all menu settings to default.	[OK], [Cancel]

Transducer Setup menu

Menu item	Description	Options (setting range)
[Transducer Setup Type]	Select the type of transducer connected. When the connected sounder is a DFF1-UHD and the transducer has a compatible TDID, [TDID] is automatically selected. Note: When the transducer model is changed or TDID is detected, the frequency and bandwidth set on [Manual] is to be reset. <ul style="list-style-type: none"> [Manual]: Manually set up the transducer. [Model]: Select the appropriate transducer model (for FURUNO or AIRMAR transducers). 	[Manual], [Model]
[Model Number]	Select the appropriate model number from the list. Note: Only available when [Transducer Setup Type] is set to [Model].	
[High Frequency Min]	Display the high frequency minimum.*	
[High Frequency Max]	Display the high frequency maximum.*	
[Low Frequency Min]	Display the low frequency minimum.*	
[Low Frequency Max]	Display the low frequency maximum.*	
[Reset Default Settings]	Reset the Transducer Setup menu settings to default.	[OK], [Cancel]

*: This item is only available for DFF3 users.

When [Transducer Setup Type] is set to [Model] and connected to DFF3

Menu item	Description	Options (setting range)
[High Frequency]	Select the model and frequency (HF & LF) of the connected transducer from the appropriate drop down menu.	
[Low Frequency]		

When [Transducer Setup Type] is set to [Manual]

Menu item	Description	Options (setting range)
[High Frequency]	Set the kHz frequency for high frequency. Setting ranges vary depending on the transducer connected.	

Menu item	Description	Options (setting range)
[Transducer Power HF]	Set the transmission power for high frequency. Note 1: This menu item is available only for DFF1, DFF1-UHD, BBDS1 and internal fish finder users. Note 2: For DFF1-UHD users, when the connected transducer TDID is not supported by the DFF1-UHD, the setting is fixed as [1000].	[600], [1000]
[Band Width (HF)]	Set the bandwidth for high frequency. Note: This item is only available for DFF3 users when the Transducer type is set to [Manual].	[10] to [100]
[Low Frequency]	Set the kHz frequency for low frequency. Setting ranges vary depending on the transducer connected.	
[Transducer Power LF]	Set the transmission power for low frequency. Note 1: This menu item is available only for DFF1, DFF1-UHD, BBDS1 and internal fish finder users. Note 2: For DFF1-UHD users, when the connected transducer TDID is not supported by the DFF1-UHD, the setting is fixed as [1000].	[600], [1000]
[Band Width (LF)]	Set the bandwidth for low frequency. Note: This item is only available for DFF3 users.	[10] to [100]

Motion sensor menu

The [Motion Sensor] menu sets up the motion sensor, which provides for stable display of the seabed, schools of fish, etc. in moderate-to-rough seas.

Note 1: For connection of NMEA0183 equipment to the TZT9F, ask your FURUNO dealer to set up the motion sensor.

Note 2: To use the heaving function, the following settings are required at the satellite compass. For the setting procedure, see the operator's manual for your satellite compass. Settings for SC-30 are done from the [IF-NMEASC] menu, settings for SC-50/110 are done from the [DATA OUT] menu.

	NMEA0183	CANbus
Sentence	ATT, HVE	
Baud rate	38400BPS	
Cycle	25ms	
PGN		Heave: 65280 Attitude: 127257

The [MOTION SENSOR] menu appears in the [Transducer Setup] menu when the [Heaving Correction] is activated in the [Fish Finder] menu. If the satellite compass SC-30 or SC50/110 is connected, set the distance between the antenna unit (or sensor) of the satellite compass and transducer (high and low if connected) here.

3. HOW TO SET UP THE EQUIPMENT

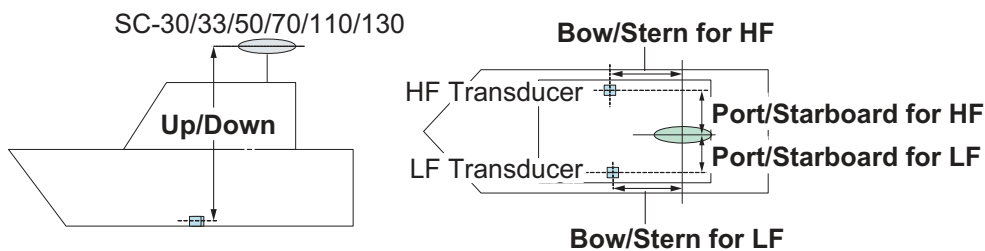

Menu item	Description	Options (setting range)
[Motion Sensor Type]	Select the sensor connected to your TZT9F unit. For all sensors other than SC-50 and SC-110, select [SC-30]. Note: This menu item is not available when [Fish Finder Source] is set to [TZT9F].	[SC30], [SC50_SC110]
[Antenna Position Bow/Stern HF (LF)]	Set the distance from the antenna unit to the transducer in the bow-stern direction. If the transducer is located on the fore side, set a positive value.	[-99.9] to [+99.9]
[Antenna Position Up/Down HF (LF)]	Set the distance from the transducer to the antenna unit in the vertical direction. If the transducer is located on the bow side, set a positive value.	[-0.00] to [+99.9]
[Antenna Port/Starboard HF (LF)]	Set the distance from the antenna unit to the transducer in the port-starboard direction. If the transducer is located on the starboard side, set a positive value.	[-99.9] to [+99.9]

3.6 Wireless LAN Setting

3.6.1 How to join an existing wireless network

By connecting to an existing network, you may download software updates and weather information from the internet.

1. Tap the **Home** icon to show the home screen and display mode settings.
2. Tap [Settings], then [General].
3. Tap [Wireless LAN Settings].
4. Tap [Wireless Mode].
5. Tap [Connect to existing LAN] to show a ✓ mark, then tap the [<] icon at the top left of the display.
6. Turn on [Wireless] in the [ENABLE WIRELESS] menu.
7. Tap [Scan] to scan the vicinity for accessible WLAN networks. Available networks are listed. To delete all WLAN networks, select [Forget All Available Networks].

8. Tap the appropriate WLAN network to show the following display.

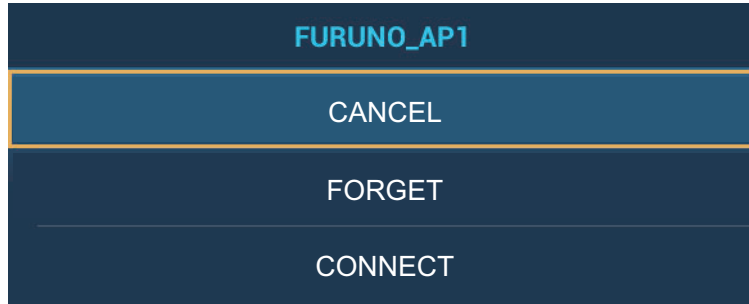

9. Tap [Connect], and the following display appears.

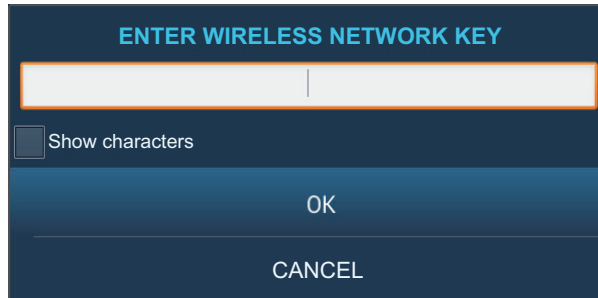

10. Use the software keyboard to enter the network key, then tap the [OK] button. To see what you have input, check [Show characters].
Note: If the network key is incorrect, an error message appears. Enter the correct key and tap [OK] again.
11. Tap [X] on the title bar to close the menu.

3.6.2 How to create a wireless LAN network

Smart devices connected to this wireless network may also connect directly to the unit, allowing use of the TZT9F applications.

1. Tap the **Home** icon () to show the home screen and display mode settings.
2. Tap [Settings] then [General].
3. Tap [Wireless LAN Settings].
4. Tap [Wireless Mode] in the [WIRELESS MODE] menu.
5. Tap [Create Local Network] to show a ✓ mark, then tap the [<] icon at the top left of the display.
6. Tap [Name] in the [LOCAL NETWORK SETTINGS] menu.
7. Using the software keyboard, name the unit, then tap the ✓ mark.
8. Tap [Password] in the [LOCAL NETWORK SETTINGS] menu.
9. Using the software keyboard, set the password, then tap the ✓ marks.
10. Tap [Local Network] in the [ENABLE LOCAL NETWORK] menu to activate the wireless network.
11. Your smart device may now be connected to the unit, through the network.
 - 1) From the smart device, select the network set at step 7.
 - 2) Input the password set at step 9.
12. Tap [X] on the title bar to close the menu.

3.7 Ferry Mode







Note: Only the SC-30, SC-33, and SCX-20 support the Ferry Mode.

Ferry mode allows the user to change the screen orientation by 180°. Note that all the above heading sensors must support heading offset command from the TZT9F. Both heading sensors and radar sensors must be powered on when the TZT9F sends the command. Both the heading sensor and radar sensor must be powered when the TZT9F sends the heading offset command to them. If the TZT9F sends the command and one of the sensors does not receive it, the heading data may be reversed. See "[Event Input Configuration]" of "[Initial Setup] menu (Other menu items)" on page 3-11.

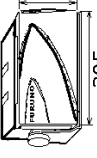
PACKING LIST TZT9F-E/-J

19BK-X-9860-1

1/1

NAME	OUTLINE	DESCRIPTION/CODE No.	Q'TY
ユニット UNIT			
マルチディスプレイ MULTI FUNCTION DISPLAY		TZT9F-* 000-037-875-00 **	1
予備品 SPARE PARTS			
予備品 SPARE PARTS		SP19-01601 001-587-730-00	1
付属品 ACCESSORIES			
付属品 ACCESSORIES		FP19-02301 001-563-920-00	1 (*1)
付属品 ACCESSORIES		FP26-00401 001-175-940-00	1 (*2)
工事材料 INSTALLATION MATERIALS			
ケーブル(クミヒン)MJ CABLE ASSEMBLY		MJ-A3SPF0019-035C 000-156-058-11	1
工事材料 INSTALLATION MATERIALS		CP19-02701 001-587-750-00	1
工事材料 INSTALLATION MATERIALS		CP19-02702 001-587-760-00	1

コード番号末尾の「**」は、選択品の代表コードを表します。

CODE NUMBER ENDING WITH " **" INDICATES THE CODE NUMBER OF REPRESENTATIVE MATERIAL.

(*1)の付属品は和文仕様専用です。

(*1) MARKED ACCESSORIES ARE FOR JAPANESE SET ONLY.

(略図の寸法は、参考値です。DIMENSIONS IN DRAWING FOR REFERENCE ONLY.)

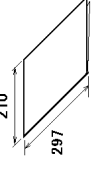
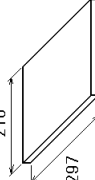
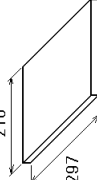
NAME	OUTLINE	DESCRIPTION/CODE No.	Q'TY
図書 DOCUMENT			
フラッシュマウント型紙 FLASH MOUNTING TEMPLATE		C42-02003-* 000-197-909-1*	1
操作要領書 OPERATOR'S GUIDE		OS*-45120-* 000-197-102-1* **	1
装備要領書 INSTALLATION MANUAL		IM*-45090-* 000-197-907-1* **	1

(*2)の付属品は英文仕様専用です。

(*2) MARKED ACCESSORIES ARE FOR ENGLISH SET ONLY.

表1 TABLE 1

寸法区分 (mm) DIMENSION	公差 (mm) TOLERANCE
L ≤ 50	±1.5
50 < L ≤ 100	±2.5
100 < L ≤ 500	±3

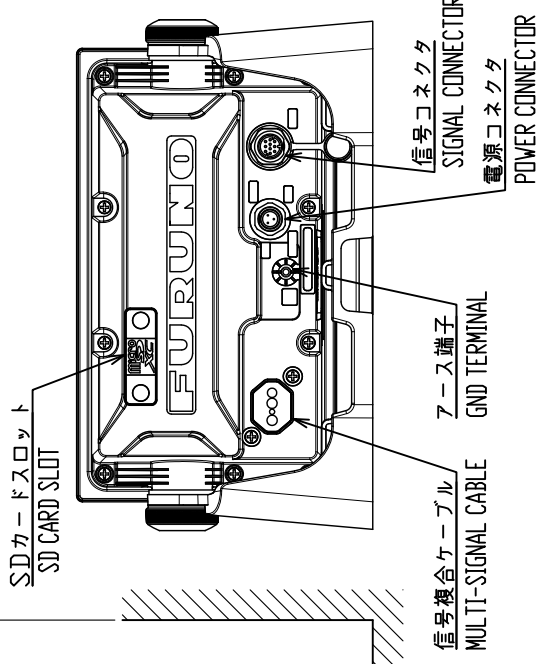
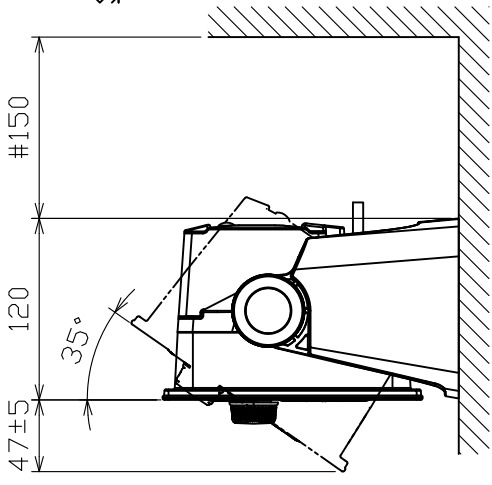
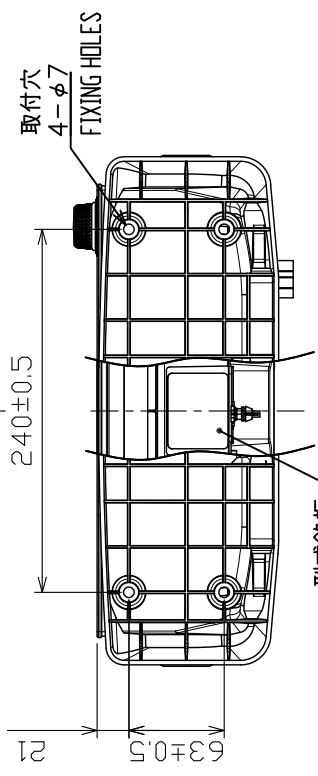
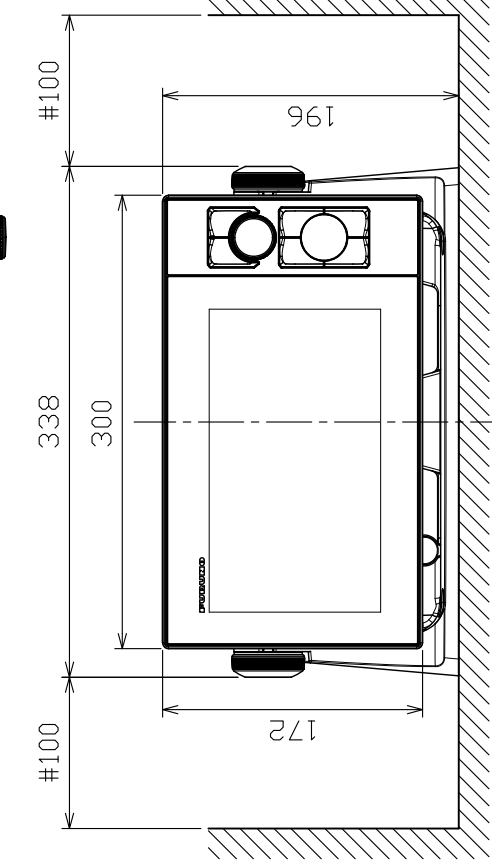
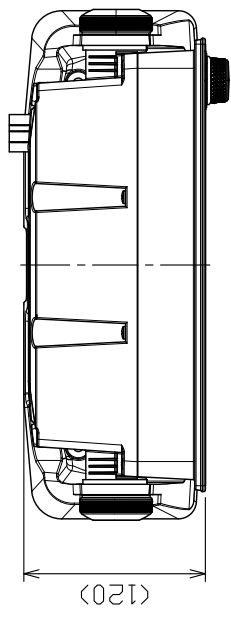

NOTE

1. TABLE 1 INDICATES TOLERANCE OF DIMENSIONS WHICH IS NOT SPECIFIED.
2. #; MINIMUM SERVICE CLEARANCE.
3. USE TAPPING SCREWS Ø5x20 FOR FIXING THE UNIT.

注記

- 1) 指定外の寸法公差は表1による。
- 2) #印寸法は最小サービスクリアランスとする。
- 3) 取付用ネジはトラスタックピンネジ呼び径5×20を使用のこと。

DRAWN	20/May/2020	I. YAMASAKI	TITLE	TZ19F
CHECKED	20/May/2020	H. MAKI	名称	マルチファンクションディスプレイ (卓上装備)
APPROVED	21/May/2020	H. MAKI	外寸図	
SCALE	1/5	MASS 3.5 SIZE 10g	質量は信号線合ケーブルを含む。 MASS INCLUDES MULTI-SIGNAL CABLE.	
JWG.No.	C4509-G02-A	REF.No.	19-034-10(G)-1	MULTI-FUNCTION DISPLAY (TABLETOP MOUNT)
				OUTLINE DRAWING

表1 TABLE 1

寸法区分 (mm) DIMENSION	公差 (mm) TOLERANCE
L ≤ 50	±1.5
50 < L ≤ 100	±2.5
100 < L ≤ 500	±3

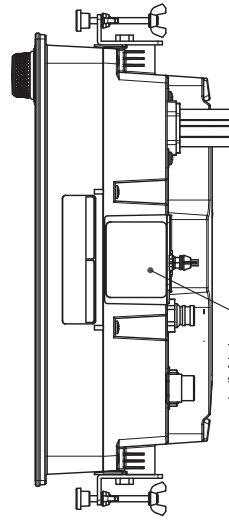
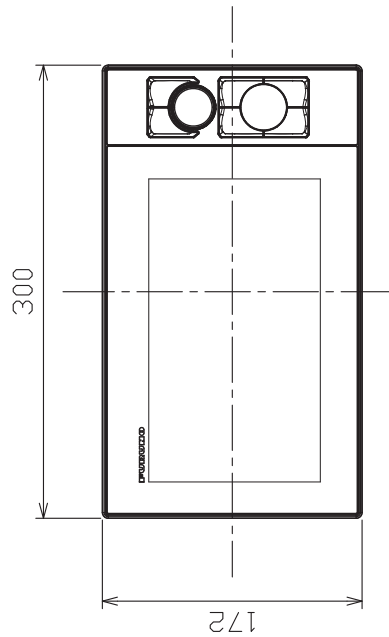
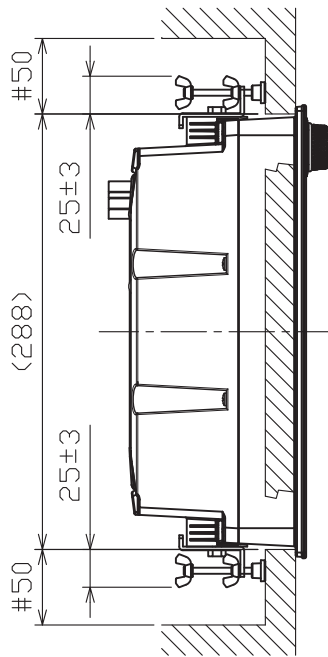

型式銘板
NAMEPLATE

注 記

- 1) 指定外の寸法公差は表1による。
- 2) #印寸法は最小サービスインスペース寸法とする。
- 3) 壁の厚さ(A)は最小5mm、最大20mmとする。

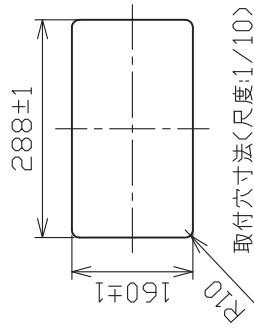

取付穴寸法(尺度:1/10)
CUTOUT DIMENSIONS (SCALE: 1/10)

2-F スポンジ9V
F-SPONGE 9V

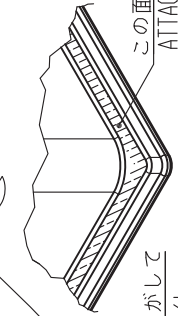

剝離紙を剥がして
本体部へ貼付
REMOVE PAPER AND ATTACH
THE SPONGES TO REAR FACE
OF BEZEL

隣接ユニットの
取付金具(近接時)
FIXING PLATE OF
NEARBY UNIT

SDカードスロット
SD CARD SLOT

23 108 #150

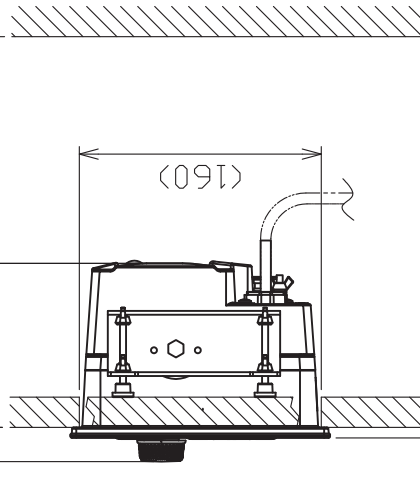

7 (A)

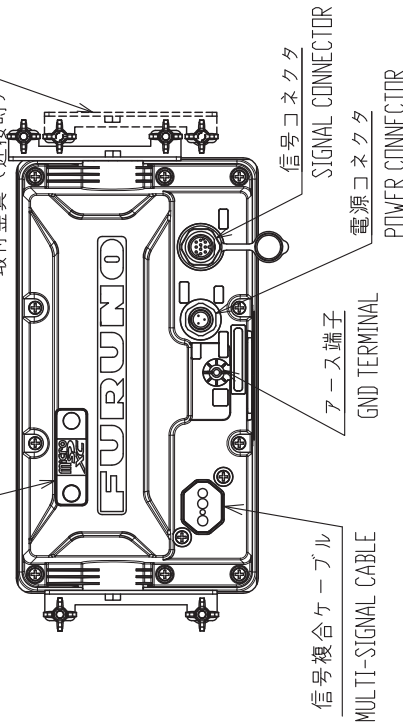

NOTE

1. TABLE 1 INDICATES TOLERANCE OF DIMENSIONS WHICH IS NOT SPECIFIED.
2. #: MINIMUM SERVICE CLEARANCE.
3. BULKHEAD THICKNESS (A): 5 ≤ A ≤ 20.

DRAWN 26/Oct/2020 I.YAMASAKI	TITLE TZT9F
CHECKED 26/Oct/2020 H.MAKI	名称 マルチファンクションディスプレイ(埋込装置S)
APPROVED 26/Oct/2020 H.MAKI	外寸図
SCALE 1/5 MASS 3.3 kg	質量は信号複合ケーブルを含む。 MASS INCLUDES MULTI-SIGNAL CABLE.
DWG.No. C4509-601-B	REF.No. 19-034-100G-3
	MULTI FUNCTION DISPLAY (FLUSH MOUNT S)
	OUTLINE DRAWING

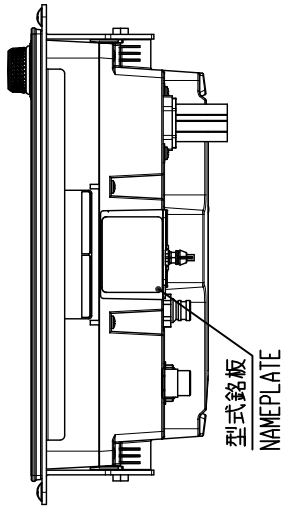
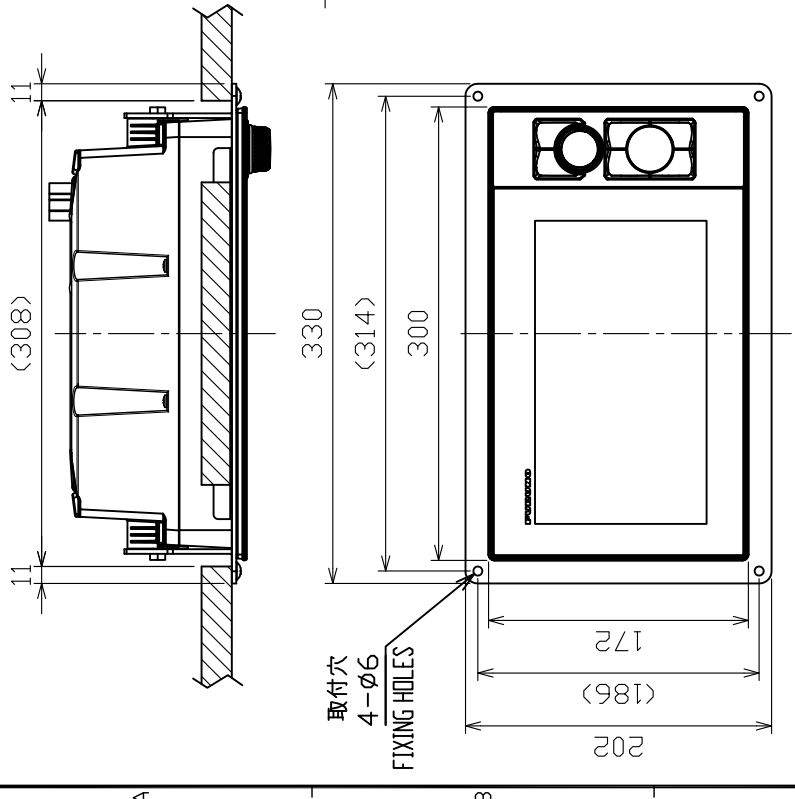
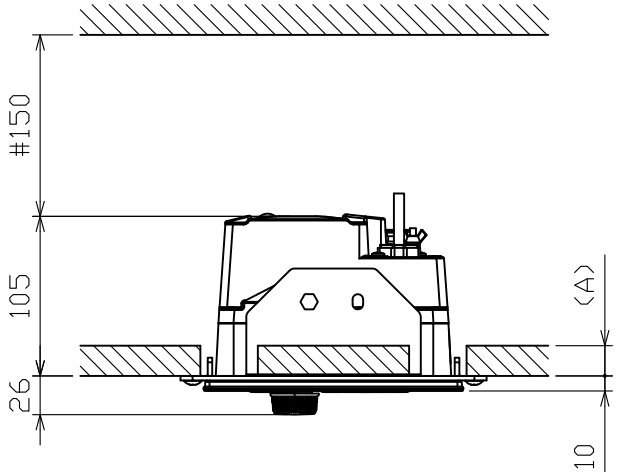
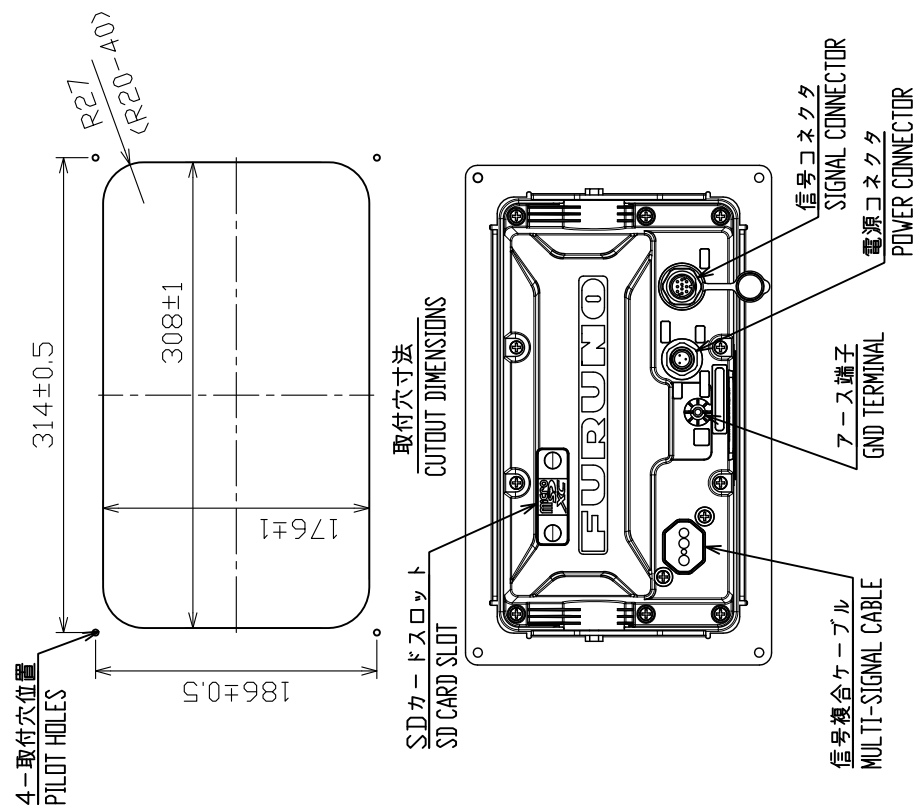

NOTE

1. TABLE 1 INDICATES TOLERANCE OF DIMENSIONS WHICH IS NOT SPECIFIED.
2. #: MINIMUM SERVICE CLEARANCE.
3. BULKHEAD THICKNESS (A): 10≦A.
4. USE TAPPING SCREWS φ5x20 FOR FIXING THE UNIT.

注 記

- 1) 指定外の寸法公差は表 1 による。
- 2) # 印寸法は最小サービスクリアランスとする。
- 3) 壁の厚さ (A) は最小 10 mm とする。
- 4) 取付用ネジはトラスタップピンネジ呼び径 5 × 2.0 を使用のこと。

DRAWN	20/May/2020	I. YAMASAKI	TITLE	TZ19F
CHECKED	20/May/2020	H. MAKI	名称	マルチファンクションディスプレイ (埋込装備F)
APPROVED	21/May/2020	H. MAKI	外形図	
SCALE	1/5	質量は信号複合ケーブルを含む。 MASS INCLUDES MULTI-SIGNAL CABLE.	NAME	MULTI-FUNCTION DISPLAY (FLUSH MOUNT F)
JWG No.	C4509-603-A	印取 LOG	REF. No.	19-034-102G-1
				OUTLINE DRAWING

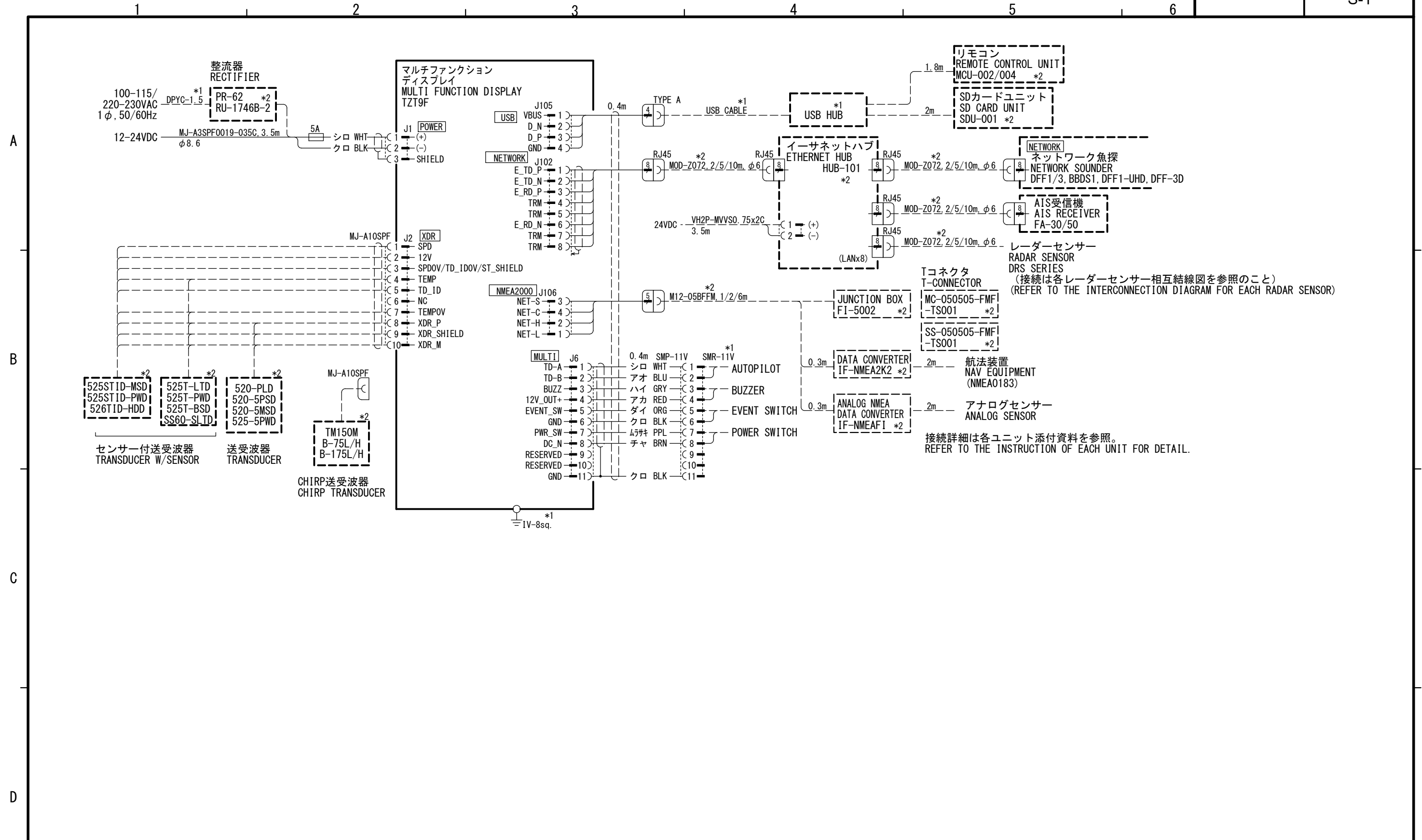

接続詳細は各ユニット添付資料を参照。
REFER TO THE INSTRUCTION OF EACH UNIT FOR DETAIL.

レーダーセンサー
RADAR SENSOR
DRS SERIES
(接続は各レーダーセンサー相互結線図を参照のこと)

注記
* 1) 造船所手配。
* 2) オプション。

NOTE
*1: SHIPYARD SUPPLY.
*2: OPTION.

DRAWN	28/Aug/2020 T. YAMASAKI	TITLE	TZT9F
CHECKED	28/Aug/2020 H. MAKI	名称	マルチファンクションディスプレイ
APPROVED	21/May/2020 H.MAKI		相互結線図
SCALE	MASS kg	NAME	MULTI FUNCTION DISPLAY
DWG No.	G4509-C01- B	REF. No.	INTERCONNECTION DIAGRAM