

Installation Manual

HALF-CIRCLE COLOR SCANNING SONAR

Model FSV-75/FSV-75-3D

SAFETY INSTRUCTIONS	i	3.11 How to Change the IP Address for the Processor Unit and Transceiver Unit ...	3-15
SYSTEM CONFIGURATION	iii	3.12 How to Set the System Time	3-16
EQUIPMENT LISTS.....	v	3.13 How to Restore Factory Default.....	3-17
 		3.14 Error Code List.....	3-17
1. MOUNTING.....	1-1	3.15 How to Register Motor Operating Times	3-18
1.1 Required Tools and Materials	1-1	3.16 How to Set the Year/Month of Oil Change	3-20
1.2 Hull Unit	1-2	3.17 [Installation Setting] Menu.....	3-21
1.3 Processor Unit	1-21	 	
1.4 Control Unit.....	1-22	APPENDIX 1 JIS CABLE GUIDE.....	AP-1
1.5 Transceiver Unit.....	1-26	APPENDIX 2 INSTALLATION CHECK LIST	AP-2
1.6 Matching Box	1-30	 	
1.7 Control Box	1-32	PACKING LISTS	A-1
1.8 Extension Box	1-33	OUTLINE DRAWINGS	D-1
1.9 How to Fill the Dome with Sonar Oil .	1-34	INTERCONNECTION DIAGRAMS	S-1
1.10 Installing to an Existing Retraction Tank.....	1-35		
2. WIRING.....	2-1		
2.1 Processor Unit	2-4		
2.2 Control Unit.....	2-10		
2.3 Transceiver Unit.....	2-11		
2.4 Control Box	2-14		
2.5 Matching Box	2-23		
2.6 Extension Box	2-24		
2.7 Input/Output Sentences (NMEA0183)	2-25		
3. ADJUSTMENTS	3-1		
3.1 DIP Switch Settings in the Processor Unit	3-1		
3.2 How to Change the Displayed Language	3-2		
3.3 How to Register the Transducer Position	3-3		
3.4 Hull Unit Checks	3-5		
3.5 How to Adjust the Heading	3-8		
3.6 How to Set the Stroke of the Hull Unit ...	3-9		
3.7 How to Configure the Own Ship Mark....	3-9		
3.8 How to Set Up a Secondary Monitor....	3-10		
3.9 How to Export/Import Backup Data...3-11			
3.10 How to Backup/Load All Settings.....	3-14		

**FURUNO ELECTRIC CO., LTD.**www.furuno.com

ECF

(Elemental Chlorine Free)

The paper used in this manual
is elemental chlorine free.

FURUNO ELECTRIC CO., LTD.

9-52 Ashihara-cho,
Nishinomiya, 662-8580, JAPAN

• FURUNO Authorized Distributor/Dealer

All rights reserved. Printed in Japan

Pub. No. IME-13630-F

(REFU) FSV-75

A : APR. 2019

F : MAR. 09, 2021





0 0 0 1 9 5 8 6 9 1 5



SAFETY INSTRUCTIONS

The installer must read the safety instructions before attempting to install the equipment.

 DANGER	Indicates a potentially hazardous situation which, if not avoided, will result in death or serious injury.
 WARNING	Indicates a potentially hazardous situation which, if not avoided, could result in death or serious injury.
 CAUTION	Indicates a potentially hazardous situation which, if not avoided, may result in minor or moderate injury.

 Warning, Caution	 Prohibitive Action	 Mandatory Action
--	--	--

 **DANGER**

 **Keep away from raise/lower shaft in hull unit when it is moving.**

Gears will cause serious injury. In case of an emergency, press the **EMERGENCY STOP** button to stop the raising or lowering of the transducer.

 **Confirm that there is no person below the transducer before raising or lowering the transducer.**

 **WARNING**

 **Be sure no water leaks in at the hull unit.**

Water leakage can sink the vessel. Also confirm that the transducer will not loosen by ship's vibration. The installer of the equipment is solely responsible for the proper installation of the equipment. FURUNO will assume no responsibility for any damage associated with improper installation.

 **WARNING**

 **Do not open the equipment unless totally familiar with electrical circuits and service manual.**

High voltage exists inside the equipment, and a residual charge remains in capacitors several minutes after the power is turned off. Improper handling can result in electrical shock.

 **Turn off the power at the mains switchboard before beginning the installation.**

Fire, electrical shock or serious injury can result if the power is left on or is applied while the equipment is being installed.

 **Do not install the equipment where it may get wet from rain or water splash.**

Water can cause fire or electrical shock, or damage the equipment.

 **If a steel tank is installed on a wooden or FRP vessel, take appropriate measures to prevent electrolytic corrosion.**

Electrolytic corrosion can damage the hull.

 **Do not remove the hull unit brake.**

There is a risk of the shaft falling out.

 **Install the specified transducer tank in accordance with the installation instructions. If a different tank is to be installed the shipyard is solely responsible for its installation, and it should be installed so the hull will not be damaged if an object strikes the tank.**

The tank or hull may be damaged if the tank strikes an object.

 **Be sure to power each unit with proper voltage.**

Connection of an improper power supply can cause fire or damage the equipment.

⚠ WARNING

! Use only the specified power and signal cable.
Fire or damage to the equipment can result if a different cable is used.

⚠ CAUTION

⚠ WORKING WITH THE SONAR OIL
Precautions

- Keep the oil away from eyes. Wear protective glasses when working with the oil. The oil can cause inflammation of the eyes.
- Do not touch the oil. Wear protective gloves when working with the oil. The oil can cause inflammation of the skin.
- Do not ingest the oil. Diarrhea or vomiting can result.
- Keep the oil out of reach of children.
- For further details, see the material safety data sheet (MSDS).

Emergency

- If the oil enters eyes, flush with clean water for about 15 min. Consult a physician.
- If the oil contacts skin, wash with soap and water.
- If the oil is ingested, see a physician immediately.
- Keep the oil out of reach of children.
- For other information, see the material safety data sheet (MSDS).

Disposal of oil and its container

- Dispose of oil and its container in accordance with local regulations. For further details, contact the place of purchase.

Storage

- Seal container to keep out foreign materials. Store in dark place.

⚠ CAUTION

! Maximum speed while the transducer is projected or being raised or lowered is as below, to prevent damage to the transducer.

Projected	Raising/ Lowering
18 kn	15 kn

⚠ Ground the equipment to prevent electrical shock and mutual interference.

! Connect the ground terminal to the ship's ground.
If the ground terminal is connected to a terminal other than the ship's ground (ex. main engine), electrolytic corrosion may occur.

⊘ Do not connect/disconnect the connector while turning the power on.
The equipment may be damaged.

! Observe the following compass safe distances to prevent magnetic compass deviation:

Unit	Standard Compass	Steering Compass
Processor Unit	2.15 m	1.35 m
Control Unit	0.30 m	0.30 m
Remote Controller	0.30 m	0.30 m
Transceiver Unit	1.85 m	1.20 m
Matching Box	1.25 m	0.80 m
Control Box	1.45 m	0.95 m
Extension Box	1.35 m	0.90 m
Motion Sensor	0.50 m	0.35 m

! If the ambient temperature around the hull unit will be below 0°C, provide the sonar compartment with a heater to keep the temperature above 0°C.
The hull unit can not work if the ambient temperature is below 0°C.

! Do not apply substances which contain organic solvents (alcohol, thinner, etc.) to the dome.
Chemical cracking may occur.

SYSTEM CONFIGURATION

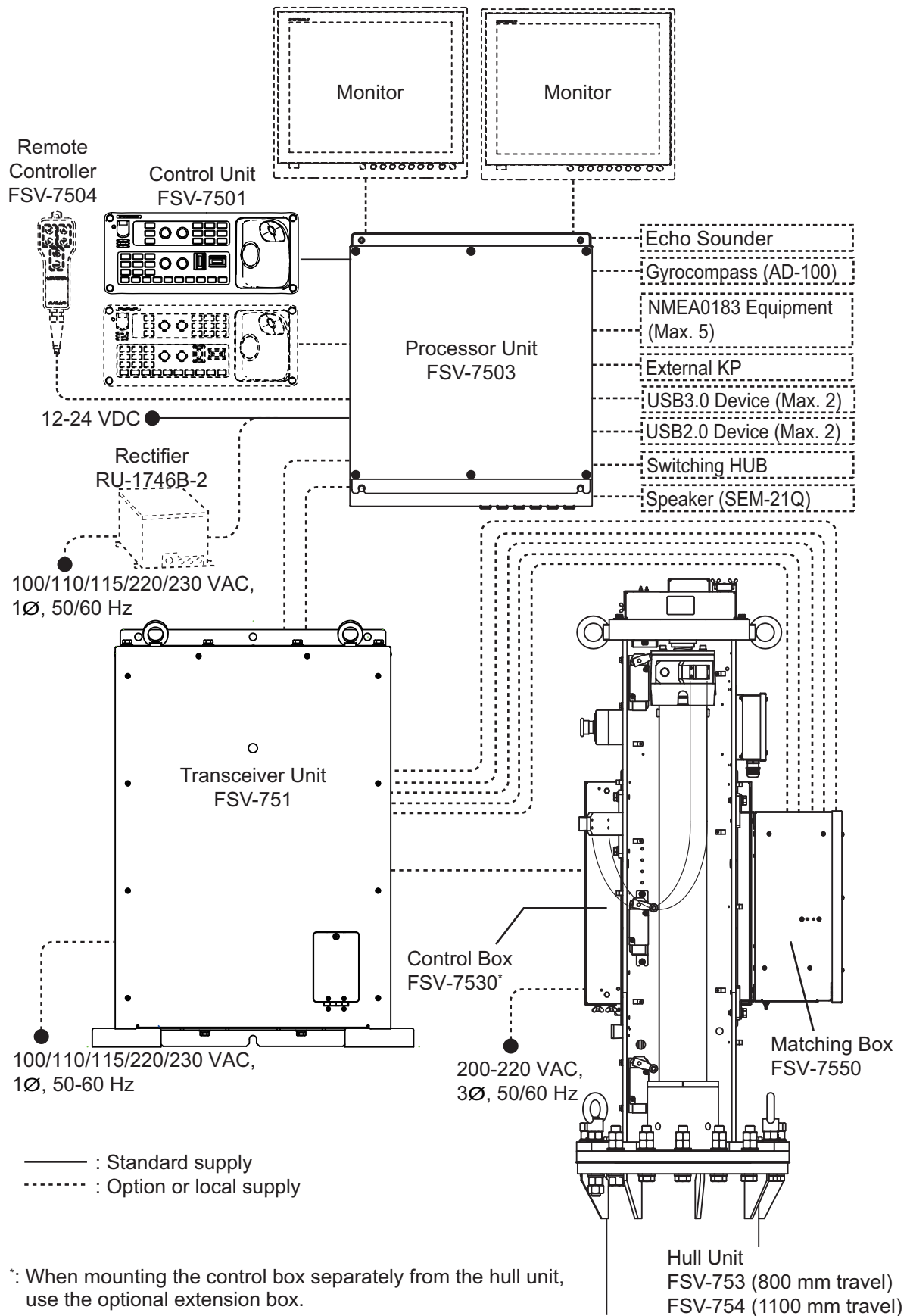

Compatible equipment

This system is compatible with the following FURUNO equipment:

Name	Model	Remarks
Monitor Unit	MU-190	Brilliance control is available with direct USB connection to the FSV-7503. The USB cable for brilliance control should be connected directly to the FSV-7503. Do not use a USB hub.
	MU-190HD	
Color LCD Sounder	FCV-1200L ^{*1}	-
	FCV-1200LM	
	FCV-1500L ^{*1}	
Fish Finder	FCV-1900 ^{*2}	
Hi-Res Fish Finder	FCV-1900B ^{*2}	
Fish Size Indicator	FCV-1900G ^{*2}	

^{*1}: Requires EXIF assembly connection (available as an optional extra) at the fish finder.

^{*2}: Connect via the FCV-1903. If a telesounder is already connected to the FCV-1900/B/G, connection between the FSV-75 and FCV-1900/B/G is not available.

EQUIPMENT LISTS

Standard supply

Name	Type	Code No.	Qty	Remarks
Control Unit	FSV-7501	-	1	With 5 m or 10 m cable
Processor Unit	FSV-7503	-	1	
Transceiver Unit	FSV-751	-	1	
Hull Unit	FSV-753	-	1	800 mm travel
	FSV-754	-		1100 mm travel
Matching Box	FSV-7550	-	1	
Installation Materials	CP10-09600	000-036-274	1	For control unit
	CP10-09700	000-036-275	1	For processor unit
	CP10-09801	001-538-860	1	For transceiver unit
	CP10-10301	001-537-600	1	For matching box
Local Assembling Parts	FSV-75-T	001-541-090	1	For hull unit with the retraction tank
	FSV-75-N	001-541-100		For hull unit without the retraction tank
Spare Parts	SP26-00301	001-080-860	1	For processor unit
	SP10-04301	001-538-850	1	For transceiver unit
	SP10-04401	001-539-770	1	For control box

Optional supply

Name	Type	Code No.	Remarks	
Control Unit	FSV-7501	-	With 5 m or 10 m cable	
Extension Box	FSV-7560	-	For separate installation of control box	
Remote Controller	FSV-7504	-	With 5 m or 10 m cable	
External Loudspeaker	SEM-21Q	-		
Interface Unit	VI-1100A	-	For connection with FCV-1200L/1500L	
Rectifier	RU-1746B-2	-		
Attachment Flange*	OP10-50	001-542-280	150 mm height raising	
	OP10-51	001-542-290	250 mm height raising	
	OP10-52	001-542-300	350 mm height raising	
	OP10-53	001-542-310	450 mm height raising	
Main Shaft Replacement Kit	OP10-54	001-544-590	For the main shaft replacement in case of marine accident	
Attachment Kit*	OP10-56	001-551-540		
Retraction Tank	OP10-57	001-551-560	For a steel vessel, 800 mm travel	
	OP10-58	001-551-620	For a steel vessel, 1100 mm travel	
Installation Materials	CP10-10100	000-036-244	LAN cable between processor unit and transceiver unit	10 m
	CP10-10110	000-036-245		15 m
	CP10-10120	000-036-246		30 m
	CP10-10130	000-036-247		40 m
	CP10-10140	000-036-248		50 m
	CP10-10150	000-036-722		100 m

EQUIPMENT LISTS

Name	Type	Code No.	Remarks	
5-pair Cable	10S2380 *10M*	001-196-330-10	Cable between processor unit and transceiver unit	10 m
	10S2380 *20M*	001-196-340-10		20 m
	10S2380 *30M*	001-196-350-10		30 m
	10S2380 *40M*	001-196-360-10		40 m
	10S2380 *50M*	001-196-370-10		50 m
	10S2380 *60M*	001-196-380-10		60 m
	10S2380 *100M*	001-196-390-10		100 m
Cable Assembly	10CA10137*5M*	001-552-210	Cable between extension box and control box (rotation motor line)	5 m
	10CA10137*10M*	001-552-220		10 m
	10CA10138*5M*	001-552-230	Cable between extension box and control box (pitch motor line)	5 m
	10CA10138*10M*	001-552-240		10 m
	10CA10139*5M*	001-552-250	Cable between extension box and control box (rotation resolver line)	5 m
	10CA10139*10M*	001-552-260		10 m
	10CA10140*5M*	001-552-270	Cable between extension box and control box (pitch resolver line)	5 m
	10CA10140*10M*	001-552-280		10 m
	10CA10110*5M*	001-552-290	Cable between transceiver unit and matching box	5 m
	10CA10110*10M*	001-552-300		10 m
	10CA10147*2M*	001-552-310	Cable between transceiver unit and control box	2 m
	10CA10147*5M*	001-552-320		5 m
	10CA10147*10M*	001-552-330		10 m
	HDMI-TO-DVI-L=5.3M	001-407-180	For connection with MU-190/MU-190HD	5.3 m
	HDMI-TO-DVI-L=10.3M	001-407-170		10.3 m

*: Required when you install the hull unit to the existing retraction tank for the CSH series.

- When tank length does not need to be extended, use the attachment kit.
- When tank length needs to be extended, use the attachment flange.

1. MOUNTING

NOTICE

Do not apply paint, anti-corrosive sealant or contact spray to coating or plastic parts of the equipment.

Those items contain organic solvents that can damage coating and plastic parts, especially plastic connectors.

1.1 Required Tools and Materials

Prepare the following tools in advance for this installation.

Name	Specification/Remarks
Hull Unit	
Wrench	Hex. size 30 mm (M20), for securing the unit
Hex Wrench	Hex. size 6 mm, for securing the dome
	Hex. size 8 mm, for fastening/unfastening the socket plug
Lithium Grease	For applying to the O-ring Recommended: Daphne Grease MP No.2 (IDEMITSU KOSAN CO., LTD.)
Ethyl Alcohol	99.5%
Waste Cloth	Whenever necessary
Hand Pump	For filling the dome with sonar oil
Bolt	M10×80, 4 pcs, used for inserting the tank guide to push the tank guide roller inwards. Note: Steel bolts are recommended to prevent scorching.
48 VDC Power Supply	Used for checking the soundome assembly Recommended: PJA300F-48 (COSEL CO., LTD.)
Power Cable	Used for checking the soundome assembly (see section 1.2.10)
Processor Unit	
Phillips-head Screwdriver	#2 for M4, used for attaching/detaching the cover
Wrench	Hex. size 10 mm (M6), for securing the unit
Shipboard Cable	TTYCSLA-1Q cable for connecting NMEA0183 equipment, external echo sounder, gyrocompass
	TTYCSLA-1 cable for external KP signal
Crimp-on Lug	FV1.25-3, for drain wire of the TTYCSLA cable
Ground Wire	IV-8sq.
Transceiver Unit	
Phillips-head Screwdriver	#2 for M4, used for attaching/detaching the cover
Wrench	Hex. size 8 mm (M4), for securing the cable clamp. Phillips-head screwdriver (#2) is also available.
	Hex. size 17 mm (M10), for securing the unit
	Hex. size 19 mm (M12), for securing the unit (deck mount only)
Power Cable	DPYCY-2.5
Crimp-on Lug	FV2-4, for DPYCY-2.5 cable

1. MOUNTING

Name	Specification/Remarks
Control Box/Matching Box/Extension Box	
Phillips-head Screwdriver	#2 for M4/M5, used for attaching/detaching the cover
Wrench	Hex. size 17 mm (M10), for securing the unit
Power Cable	TPYCY-4 cable, for control box
Crimp-on Lug	FV5.5-4, TPYCY-4 and FA-TPYCY-4 cable
	FV1.25-4, PNCTF-S 4C×0.75 cable
Control Unit	
Phillips-head Screwdriver	#2 for M5, for securing the unit
Ground Wire	IV-1.25sq.
Others	
Terminal Opener*	For wiring terminal connector
Vinyl Tape	For fabricating cables
Heat Shrinkable Tube	For drain wire of the TTYCSLA cable

*: Pre-attached inside the transceiver unit, processor unit, control box and extension box.

1.2 Hull Unit

Note: Handle the transducer carefully. Rough handling will damage its sensitive components.

1.2.1 Installation considerations

Decide the location of the hull unit through consultation with the dockyard and ship owner. When deciding the location, the following points should be taken into account.

- Select an area where propeller noise, cruising noise, air bubbles and interference from turbulence are at a minimum. Generally, the point at 1/3 to 1/2 of the ship's length from the bow on or near the keel is optimum. On-the-keel installation is advantageous for minimizing oil consumption in comparison with off-the-keel. If the hull unit can not be installed on the keel, the center of the retraction tank should be within 600 mm from the keel to prevent a rolling effect. For large ship with deep draft, the hull unit can be installed at the bow.

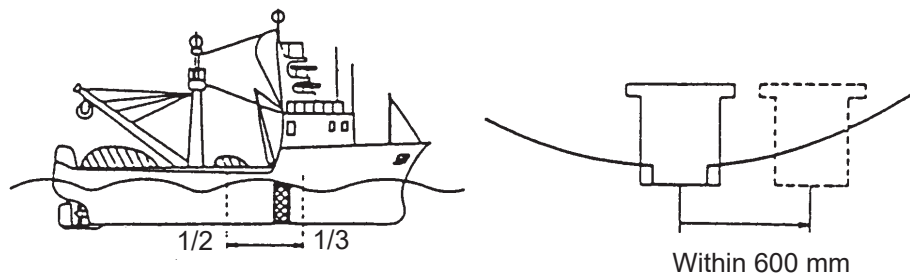

- Select a place where the hull bottom is flat and the draft is sufficiently deep. Normally, the transducer should protrude at least 500 mm beyond the keel to minimize the effect of air foam and bubbles.

- Select a place where interference from other transducers is minimal. The hull unit should be at least 2.5 m away from the transducers of other equipment.
- No obstacle should be in the fore direction since it causes a shadow zone and aeration, resulting in poor sonar performance.
- Select a mounting location, considering the ship's bottom structure and other sonar equipment. If the ship's bottom structure and transducer for other sonar equipment is projected more than the FSV-75 transducer, the FSV-75 cannot display sonar echoes correctly. Similarly, if the FSV-75 transducer blocks other sonar transducer, other sonar equipment cannot display the sonar echoes correctly.
- In the case of a bilge keel, select a location as far from the bilge as possible.
- Select a location away from indents and protrusions on the hull, especially indents, as they can create noise interference and cause poor sonar performance.
- Referring to the outline drawings at the back of this manual, allow sufficient space for maintenance and service.
- If the ambient temperature will be below 0°C, provide the sonar compartment with a heater to keep the temperature above 0°C. The hull unit can not work if the ambient temperature is below 0°C.
- Prepare a secure and firm safety fence for the hull unit, to prevent accidental injury from the moving hull unit. The safety fence should be easily removable for maintenance and allow room for the connected cables to swing freely with pitch, roll and heave. The power switch on the control box should be operable from outside the safety fence.
- After you mount the hull unit, be sure to install anti-vibration stays.

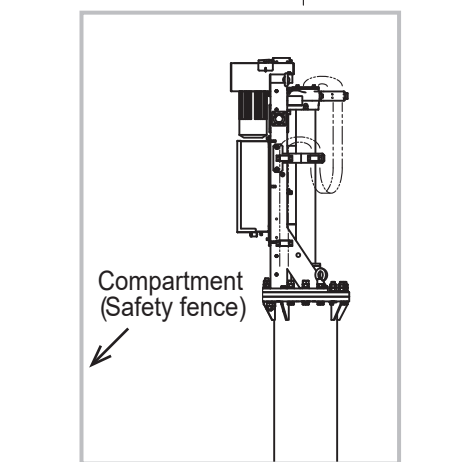
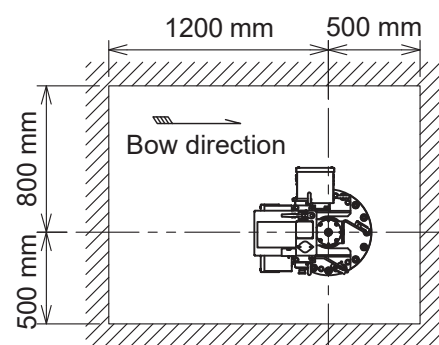

1. MOUNTING

1.2.2 Guideline for how to shorten the retraction tank

The recommended tank length for 800 mm and 1100 mm travel hull units is as follows:

- 800 mm travel: 900 mm retraction tank is recommended.
- 1100 mm travel: 1200 mm retraction tank is recommended.

Shorten the tank as necessary so that the transducer positions well below the keel when it is fully lowered. The following table provides guidelines for shortening the tank. Refer also to the retraction tank installation drawing at the back of this manual.

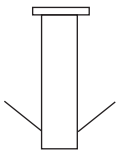
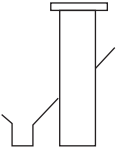
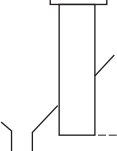
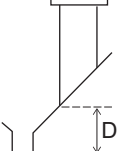
Installation Method				
Travel				
800 mm travel	Cut 0-100 mm from the end.		Cut 0-100 mm from the end. Note that the length "D" must be less than 200 mm.	
1100 mm travel	Cut 0-100 mm from the end.		Cut 0-100 mm from the end. Note that the length "D" must be less than 500 mm.	

Note 1: Adjust the position for the TX limit switch, according the retraction tank length. For how to adjust the position for the TX limit switch, see section 1.2.8.

Note 2: When maximum length is removed and "D" is at minimum, the effect of aeration is minimized because the transducer fully protrudes in water.

Guideline for the installation of the retraction tank

- If the keel plate on the inside of the hull is not adequate for installing the retraction tank, install a secondary keel plate.
- Install the retraction tank where the keel plate and hull frame intersect.
- If there is no suitable location where the hull frame and keel intersect, install suitable "T" shaped reinforcement ribs, then weld the base of the frame to the reinforcement ribs and the sides of the reinforcement ribs to the hull walls or other nearby reinforcement ribs. The reinforcement ribs should be secured in the fore, aft, port and starboard directions.
- Install the reinforcement ribs as near as possible to the top of the retraction tank, allowing 150 to 200 mm space for tightening of nuts and bolts.
- Fit a doubling plate (a plate added to another to give extra strength or stiffness) to the location where the retraction tank is welded to the hull bottom. While it is recommended that both sides attach to the hull, consult with the installer regarding length and diameter.
- The thickness for doubling plates and reinforcement ribs is 12 mm minimum.

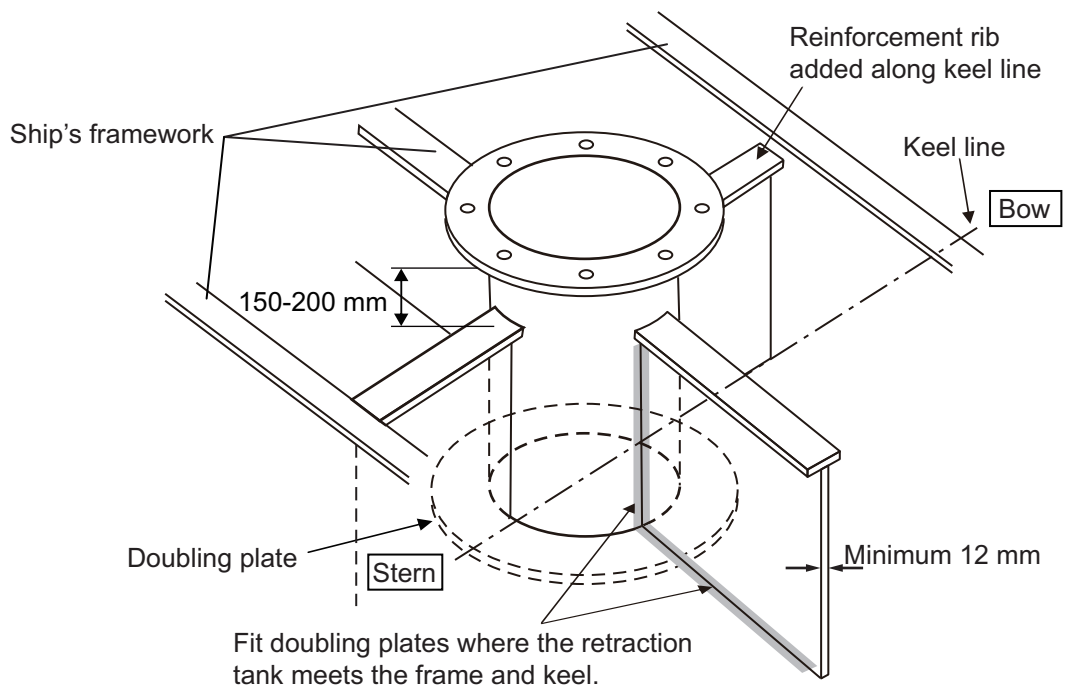

1.2.3 Preparation when a FRP retraction tank (inner diameter: 306 mm) is used

Note: The following procedure is **required only when a FRP retraction tank (inner diameter: 306 mm) is used**. If a steel retraction tank (inner diameter 316 mm) is used, skip the following procedure.

1. Unfasten the six countersunk head screws (M5×10) to remove the contact plate (four locations). Discard the removed contact plates and screws.
2. Remove the three hex socket bolts (M4×8) that secure the spring assembly (four locations).
3. Rotate the four spring assemblies by 90° in the direction of the arrow on the bottom of the spring assembly, then secure the spring assemblies using the hex socket bolts that were removed at step 2.
If you cannot rotate the spring assembly by hand, use a tool such as a wrench whose hex size is 19 mm.
4. Check that the four rollers on the side of the tank guide are pushed inwards approx. 5 mm.

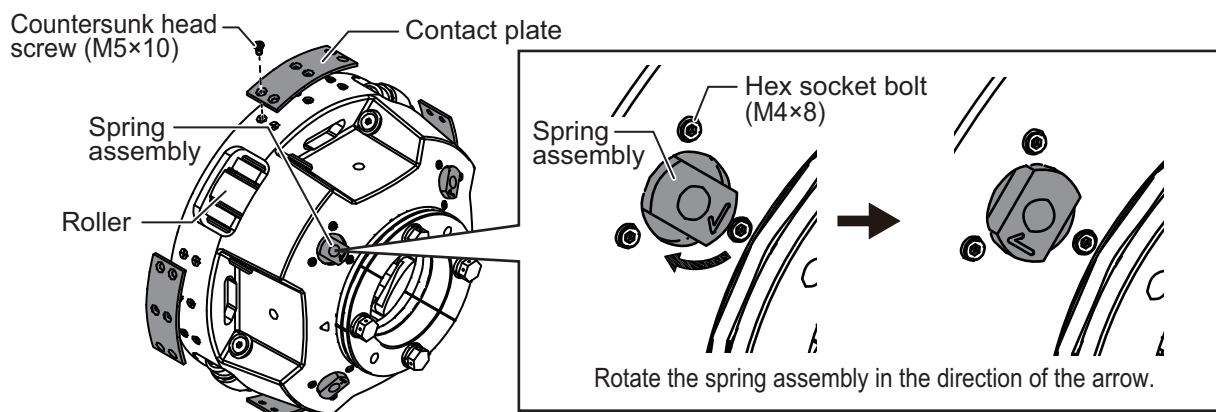

1.2.4 Preparation before installing the hull unit on the retraction tank

An anti-vibration guide is attached to the FSV-75 hull unit shaft. The rollers on the guide can prevent the hull unit from being installed into the retraction tank. For this reason, the rollers must be pushed inwards **BEFORE** installing the hull unit into the retraction tank.

Note: The following procedure is also required when you remove the hull unit from the retraction tank.

1. Unfasten the two wing bolts at the top of the hull unit, then rotate the motor cover.
2. Pull the release lever away from the holder.
3. Attach the ratchet wrench, referring to the figure at step 6.
4. Push the release lever up or down to release the motor brake, keeping a firm hold on the ratchet wrench.
5. With the motor brake released, turn the ratchet counter-clockwise to raise the shaft (tank guide).
6. While keeping a firm hold on the ratchet wrench, let go of the release lever.

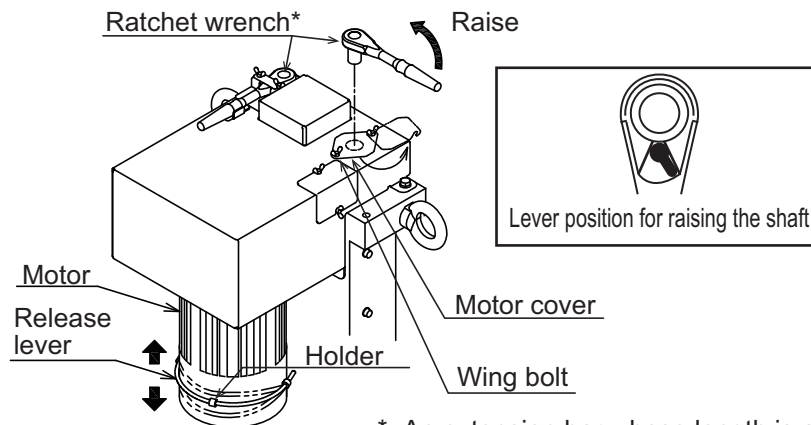
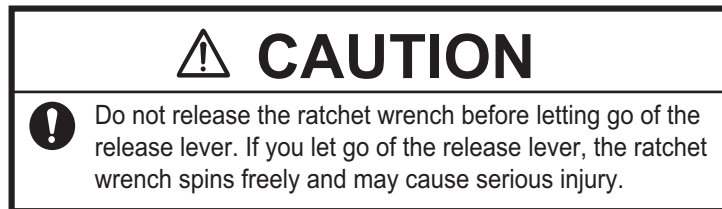

*: An extension bar whose length is approx. 40 mm may improve work efficiency.

7. Repeat step 4 to step 6 to raise the shaft (tank guide) until the gap between the tank guide and pedestal is approx. 13 mm (for the steel retraction tank (inner diameter: 316 mm)) or 8 mm (for the FRP retraction tank (inner diameter: 306 mm)). When the shaft is raised, the roller springs are forced downwards by the pedestal, pushing the rollers inwards.

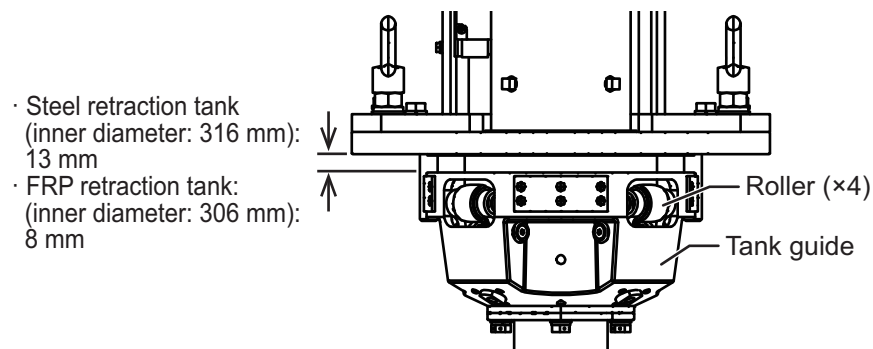

Note: Roller springs reactively push against the shaft, which can add load to the ratchet as the shaft is raised. Keep this in mind when raising the shaft and continue to raise until the gap between the pedestal and the tank guide is approximately 13 mm (for the steel retraction tank (inner diameter: 316 mm)) or 8 mm (for the FRP retraction tank (inner diameter: 306 mm)).

8. Reattach the release lever to the holder.
9. Replace the ratchet wrench and motor cover.

1.2.5 How to install the hull unit on the retraction tank

Weld the retraction tank and allow sufficient time for cooling. Install the hull unit as follows:

Note: For installation using an existing CSH series hull unit retraction tank, see section 1.10.

1. Clean the flange and O-ring groove of the retraction tank (welded to hull). Use waste cloths moistened with ethyl alcohol.
2. Coat the O-ring and O-ring groove with lithium grease, then place the O-ring in its groove on the tank flange.
3. Orient the hull unit so that the bow mark (inscribed on its flange) points toward the ship's bow.

Note: If the bow mark on the hull unit flange is not facing the ship's bow, rotate the transducer so that the bow mark on the transducer points toward the ship's bow (see section 1.2.9).

4. Confirm the following points, then place the hull unit on the retraction tank.
 - Clean the flange platform.
 - Wipe the undersurface of the hull unit flange with clean waste cloths.
 - Keep O-ring in its groove.

1. MOUNTING

- Coat the threads of the bolts with a slight amount of lithium grease to prevent scorching, then secure the hull unit to the retraction tank, referring to the following figure.

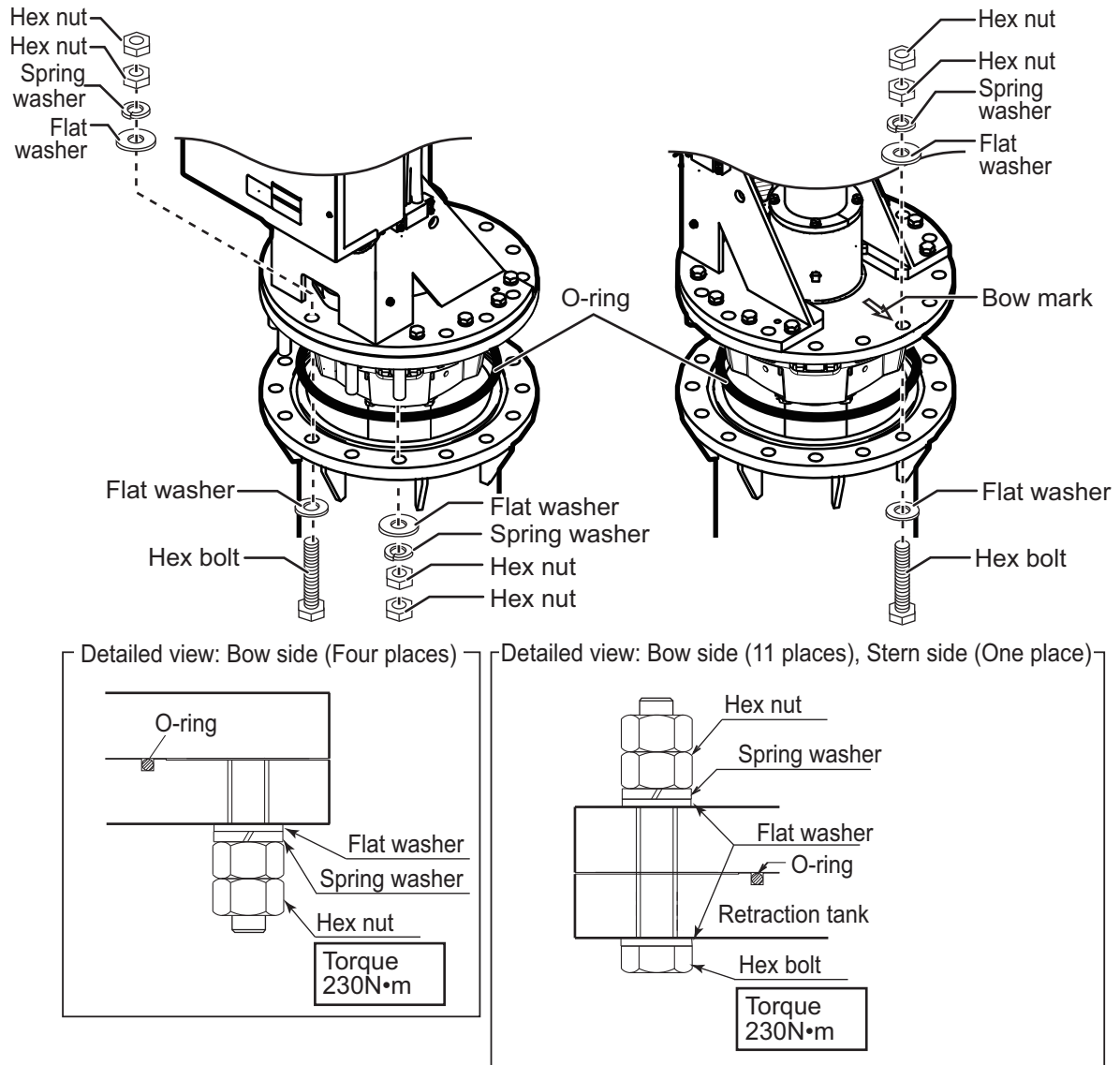

- Lower the transducer, then confirm that the rollers on the tank guide are not projected from the retraction tank.
Tank guide must be positioned 30 mm inside from the bottom of the retraction tank.

Note: The position for the lower limit switch can be raised 100 mm by using the bolt holes on the flange assembly.

1.2.6 How to remount the emergency switch

The emergency switch is attached to the starboard side of the hull unit. If the starboard side clearance is not sufficient for switch operation, the switch may be remounted on the port side.

1. Unfasten the four screws to remove the box base.
2. Unfasten the two screws to remove the box cover.

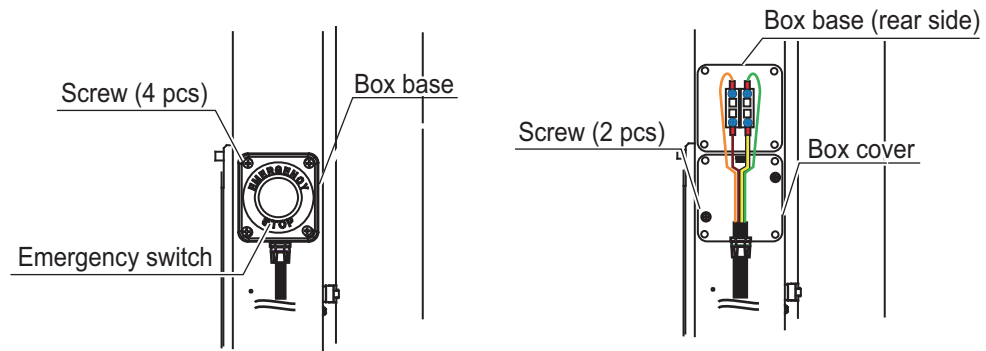

3. Remount the emergency switch to the port side.
Note: For the 800 mm travel hull unit, rotate the emergency switch by 90° so that the emergency switch cable passes through the rear side of the hull unit (see the figure at step 4).
4. Secure the emergency switch cable, using the two wiring bands. Wiring band must be secured to the hull unit, using pan head screws (M4×12).

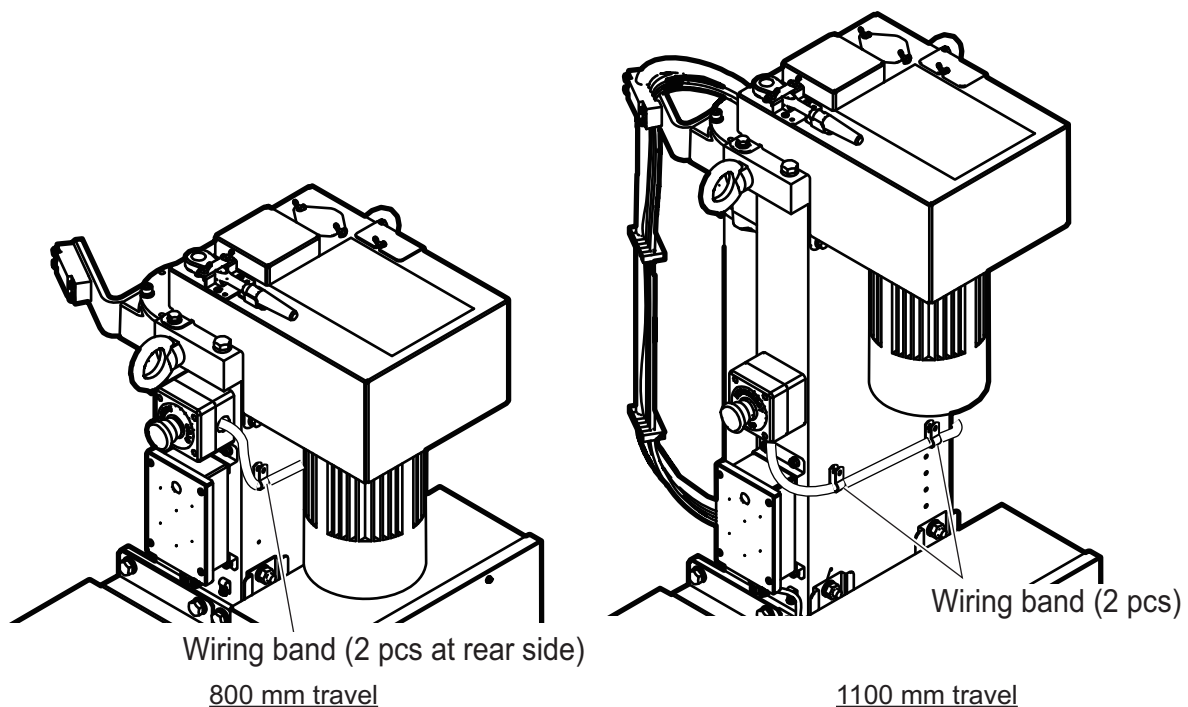

1. MOUNTING

1.2.7 How to install the stays (anti-vibration and anti-shock measures)

This measure must be done after installing the hull unit to prevent damage from vibration or impact shock to the transducer. Stays should be as sturdy as possible (75×75×9 mm minimum recommended). Install a minimum of two stays, one in the aft direction, one in the fore direction. Where possible install two more stays (one in the port and one in the starboard direction), making a total of four stays. Where the hull unit is installed off center from the bow-stern line, install the stays at right angles with the bow mark on the hull unit.

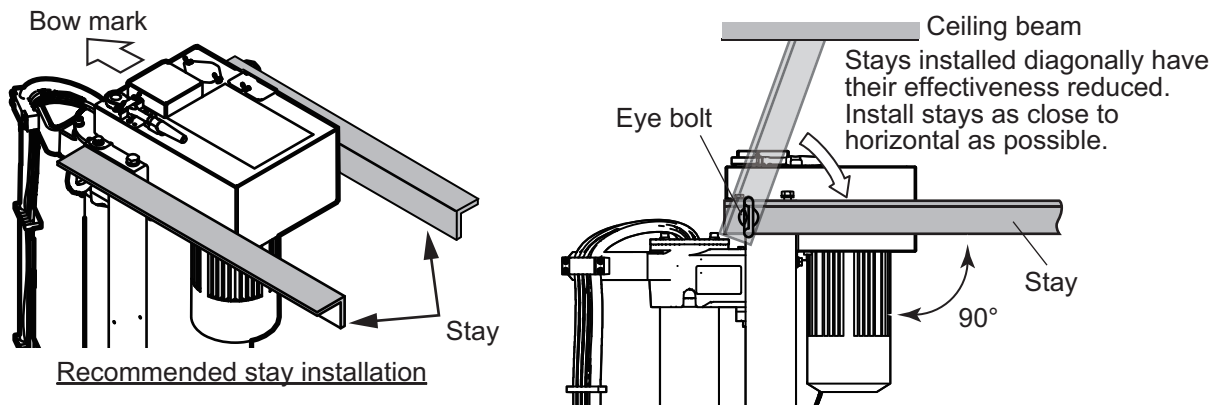

Where horizontal installation of the stays is not possible, install the stays in a diagonal manner to reduce vibration in the hull unit.

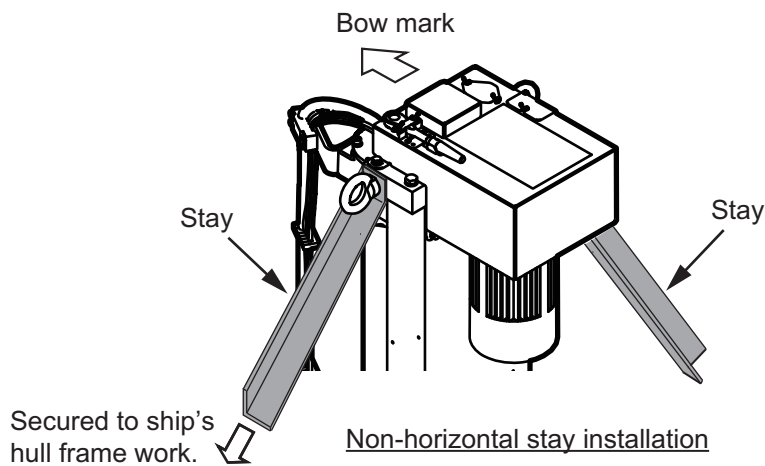

1.2.8 How to adjust the TX limit switch position

Adjust the TX limit switch position so that the switch is turned on where the transmitting face of the transducer is projected from the hull unit.

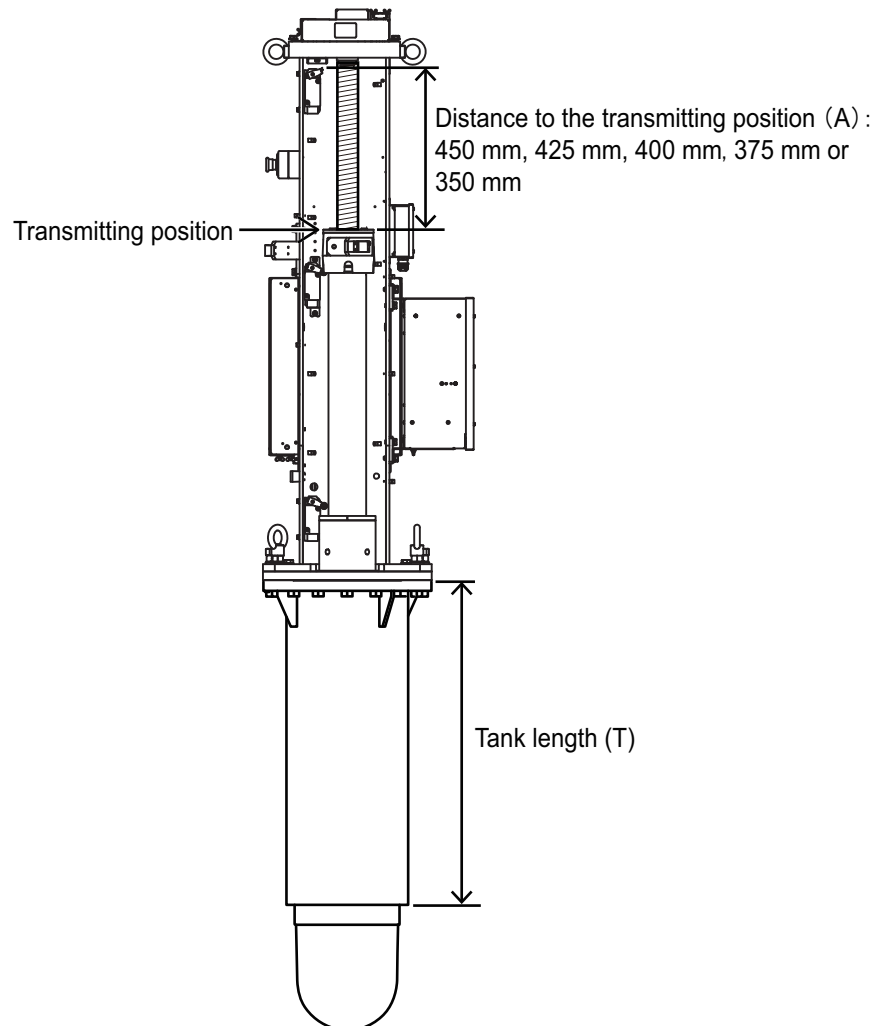

Distance to the transmitting position (A) can be selected from 450 mm, 425 mm, 400 mm, 375 mm or 350 mm. The distance to the transmitting position can be calculated with the following formula. Select the value closest to the calculation.

- 800 mm travel: $A = T - 550$ mm
- 1100 mm travel: $A = T - 850$ mm

For example, when the tank length (T) for the 800 mm travel is 920 mm, the calculated value is " $A = 920 - 550 = 370$ mm". Therefore, adjust the TX limit switch so that the distance to the transmitting position is 375 mm.

Note: The transducer can transmit when the transducer is projected 270 mm from the retraction tank.

1. MOUNTING

At factory default, the distance to the transmitting position is 450 mm (tank length: 1000 mm (800 mm travel) or 1300 mm (1100 mm travel)). To adjust the distance to the transmitting position, unfasten the two mounting screws (M6) to remount the TX limit switch.

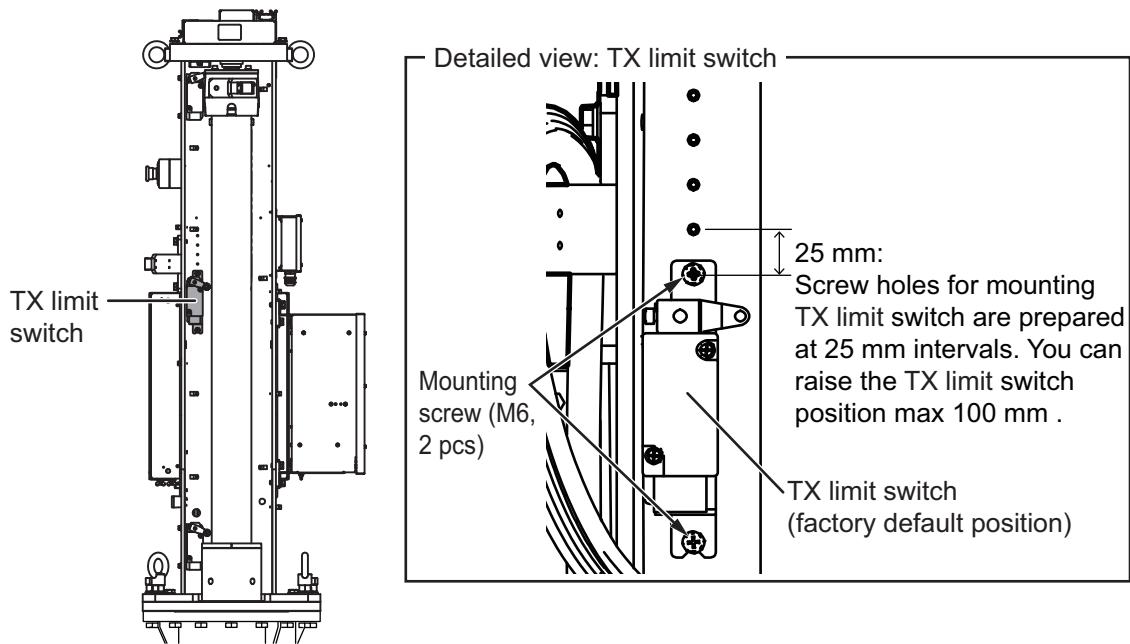

1.2.9 How to adjust the bow mark direction on the transducer

When you cannot face the bow mark on the hull unit flange to the bow direction due to installation space, rotate the transducer so that the bow mark on the transducer points toward the ship's bow.

1. Release the transducer cable from the three cable clamps.

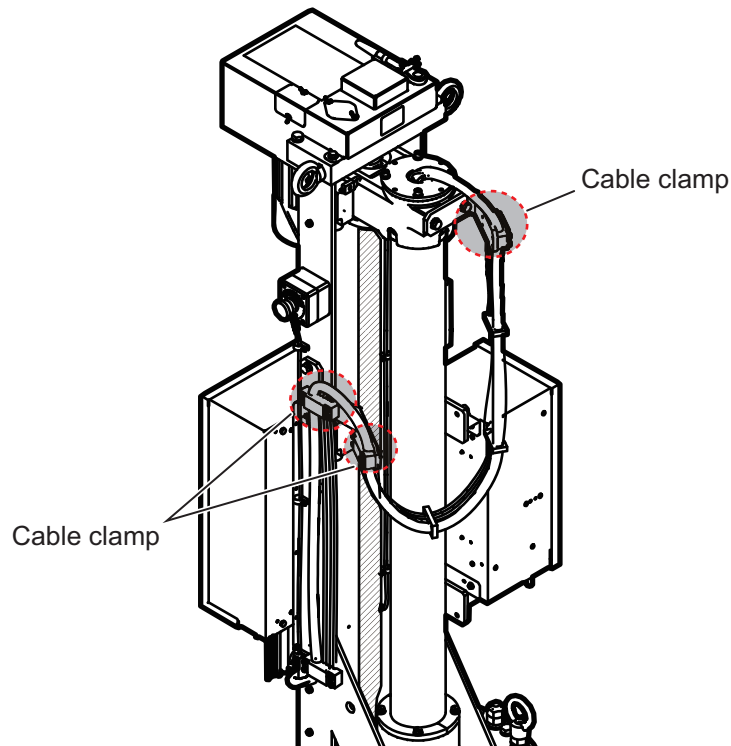

2. Lower the transducer manually.
Note: For how to lower the transducer manually, follow the procedure indicated on the label at the top of the hull unit.
3. Mount the transducer on a base to prevent the transducer from falling accidentally.

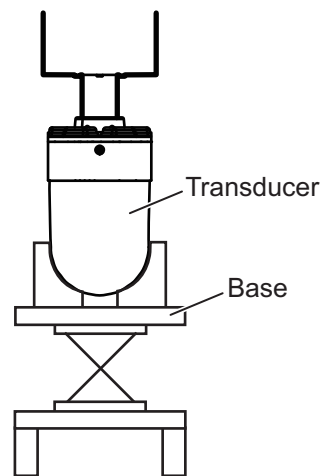

4. Insert four bolts (M10×80, supplied locally) to the hole on the bottom of the tank guide to push the tank guide rollers inwards.
Note: Steel bolts are recommended to prevent scorching.

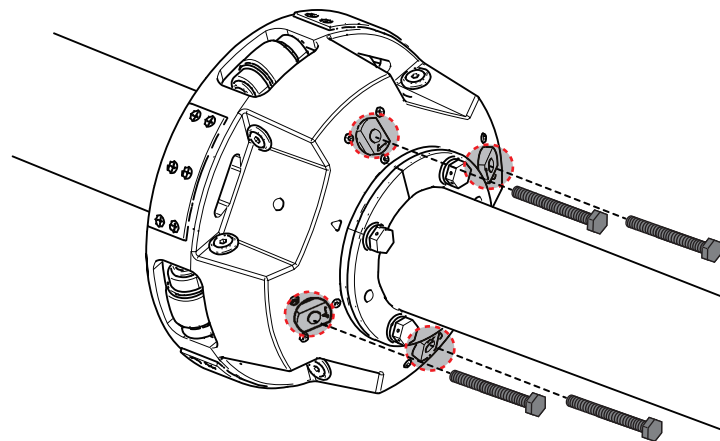

1. MOUNTING

5. Unfasten the four hex socket bolts on the top of the main shaft to disassemble the cable gasket assembly.

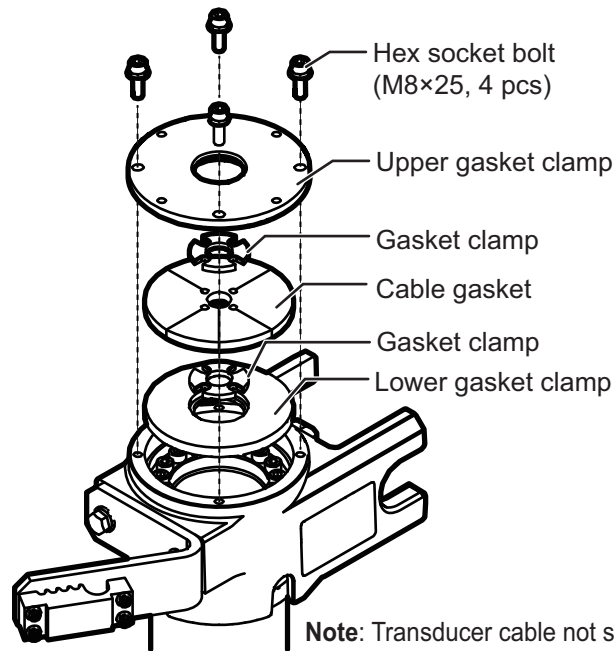

6. Unfasten the 16 hex socket bolts to remove the trunnion receptacle from the main shaft.

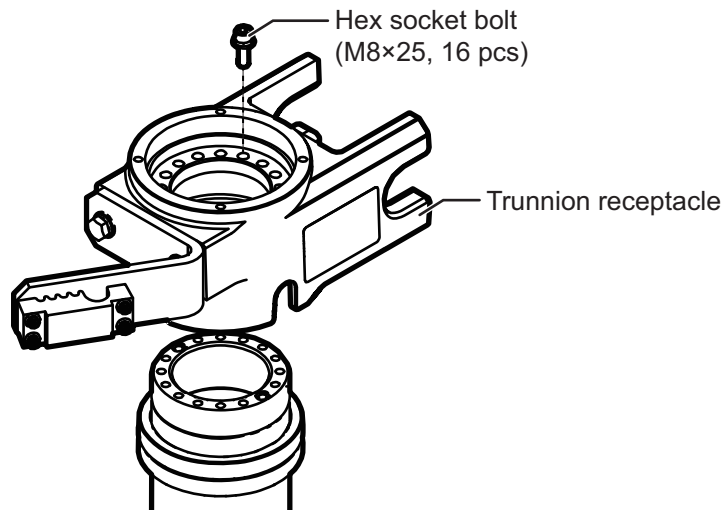

7. Rotate the transducer so that the bow mark on the transducer points toward the ship's bow.

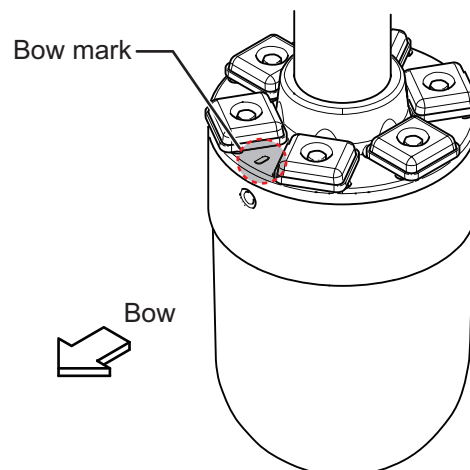

8. Reattach the trunnion receptacle.
9. Assemble the cable gasket on the top of the main shaft.
Note: The following marking appears on the cable gasket and transducer cable. Assemble the cable gasket so that each marking points toward the ship's bow.

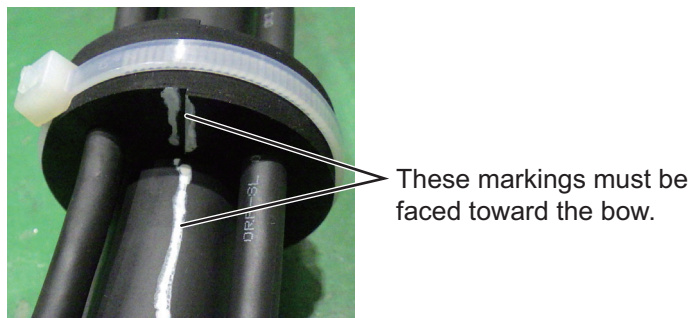

10. Remove the four bolts inserted to the tank guide at step 4.
11. Raise the transducer manually.
12. Secure the transducer cable with the three clamps indicated at step 1.
Note: For how to route the transducer cable, see page 2-3.

1.2.10 How to check the soundome assembly operation

After installing the hull unit, check the soundome assembly operation before wiring.

1. Prepare a power cable (supplied locally) to supply the power to the soundome assembly.

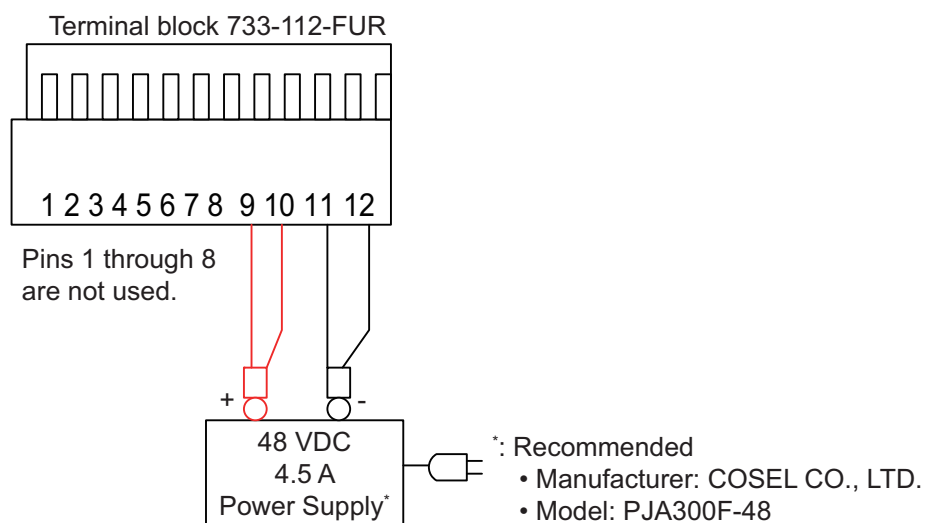

2. Turn the control box breaker off.

1. MOUNTING

3. Open the control box cover, then make connections referring to the following figure.

The operation check can be performed regardless of the settings for connectors other than the ones indicated in this procedure.

Connection with the soundome assembly

Following connectors must be connected.
The hull unit is supplied with the following connectors connected.

- TB1 (HFLT board)
- TB8
- TB10

Connection with the 48 VDC power supply

- TB2: Connect the power cable prepared at step 1.

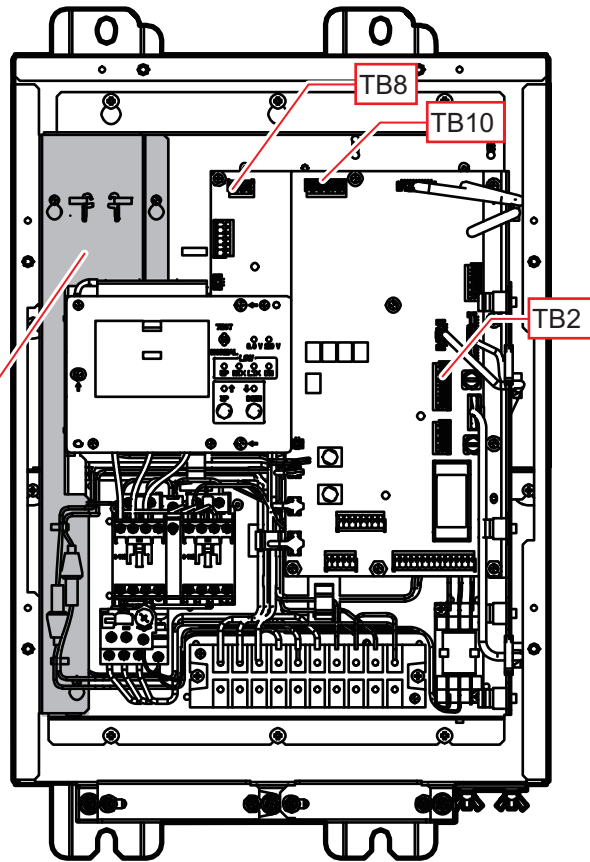
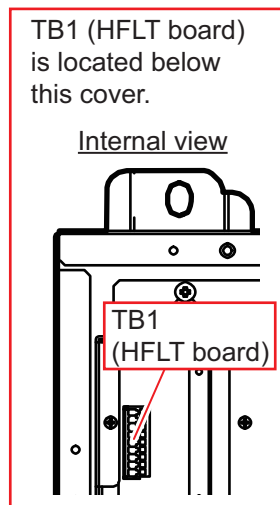

4. Turn the 48 VDC power supply on to supply the power to the soundome assembly, then confirm that the 3.3 V LED on the control box lights steadily.

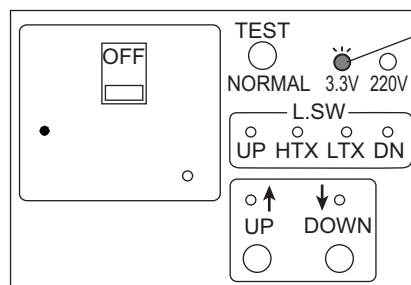

This LED lights steadily after powering the soundome assembly.

When the soundome assembly is powered correctly, an operation check is performed automatically. The decimal point on the display LED flashes during the operation check. The operation check takes approx. one minute.

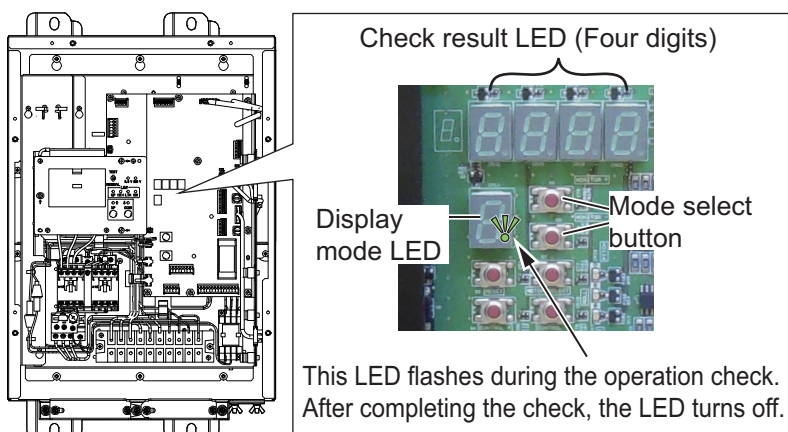

5. After completing the operation check, press the mode select button to change the display mode LED indication to "E".
When the display mode LED shows "E", when an error is detected, the error code appears on the check result LED. For details about the error codes, see "Error code" on page 1-17.
Note: If errors are detected during the operation check, the check result LED shows the error code automatically.
6. Turn the 48 VDC power supply off and disconnect the power cable from TB2.
7. Reattach the control box cover.

Error code

Error codes appear on the check result LED as alphanumeric characters.

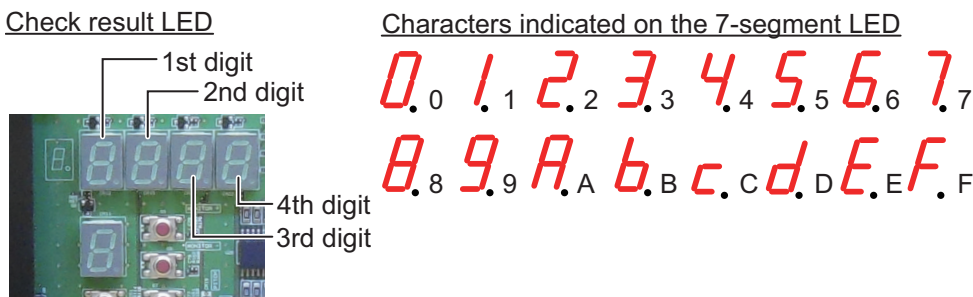

Use the following four tables to confirm the error code. For example, when the error code is "0A00", "6 HCTL Power Error" and "8 hull unit Operation Error" occur. For error details, see the table on the following page.

- Error that can be indicated by the 1st digit LED:

Error		Character on the seven-segment LED ✓: Error occurs.															
		0	1	2	3	4	5	6	7	8	9	A	B	C	D	E	F
1	Motion Sensor Connection Error or Motion Sensor ROM/RAM Error	-	✓	-	✓	-	✓	-	✓	-	✓	-	✓	-	✓	-	✓
2	Motion Sensor Self Test Error	-	-	✓	✓	-	-	✓	✓	-	-	✓	✓	-	-	✓	✓
3	Motion Sensor Power Error	-	-	-	-	✓	✓	✓	✓	-	-	-	-	✓	✓	✓	✓
4	Motion Sensor Calibration Error	-	-	-	-	-	-	-	-	✓	✓	✓	✓	✓	✓	✓	✓

1. MOUNTING

- Error that can be indicated by the 2nd digit LED:

Error		Character on the seven-segment LED ✓: Error occurs.															
		0	1	2	3	4	5	6	7	8	9	A	B	C	D	E	F
5	Resolver Driver Error (Tilt)	-	✓	-	✓	-	✓	-	✓	-	✓	-	✓	-	✓	-	✓
6	HCTL Power Error	-	-	✓	✓	-	-	✓	✓	-	-	✓	✓	-	-	✓	✓
7	Fan Rotation Error	-	-	-	-	✓	✓	✓	✓	-	-	-	-	✓	✓	✓	✓
8	Hull Unit Operation Error	-	-	-	-	-	-	-	-	✓	✓	✓	✓	✓	✓	✓	✓

- Error that can be indicated by the 3rd digit LED:

Error		Character on the seven-segment LED ✓: Error occurs.															
		0	1	2	3	4	5	6	7	8	9	A	B	C	D	E	F
9	Motor Test Error (Tilt)	-	✓	-	✓	-	✓	-	✓	-	✓	-	✓	-	✓	-	✓
10	Motor Driver Error (Rotate)	-	-	✓	✓	-	-	✓	✓	-	-	✓	✓	-	-	✓	✓
11	Motor Driver Error (Tilt)	-	-	-	-	✓	✓	✓	✓	-	-	-	-	✓	✓	✓	✓
12	Resolver Driver Error (Rotate)	-	-	-	-	-	-	-	-	✓	✓	✓	✓	✓	✓	✓	✓

- Error that can be indicated by the 4th digit LED:

Error		Character on the seven-segment LED ✓: Error occurs.															
		0	1	2	3	4	5	6	7	8	9	A	B	C	D	E	F
13	HCTL ROM/RAM Error	-	✓	-	✓	-	✓	-	✓	-	✓	-	✓	-	✓	-	✓
14	Resolver Test Error (Rotate)	-	-	✓	✓	-	-	✓	✓	-	-	✓	✓	-	-	✓	✓
15	Resolver Test Error (Tilt)	-	-	-	-	✓	✓	✓	✓	-	-	-	-	✓	✓	✓	✓
16	Motor Test Error (Rotate)	-	-	-	-	-	-	-	-	✓	✓	✓	✓	✓	✓	✓	✓

The following table provides detailed information for each error.

Error		Meaning	Possible reason(s)
1	Motion Sensor Connection Error or Motion Sensor ROM/RAM Error	There is a problem communicating with the motion sensor, or a motion sensor error was detected at startup.	<ul style="list-style-type: none"> • Motion sensor is not connected to the HCTL board. • Motion sensor cable is damaged. • HMS board error
2	Motion Sensor Self Test Error	Motion sensor self test detects one or more errors.	HMS board error
3	Motion Sensor Power Error	Motion sensor self test detects one or more errors.	HMS board error
4	Motion Sensor Calibration Error	Motion sensor calibration test detects one or more errors.	HMS board error
5	Resolver Driver Error (Tilt)	Resolver driver self test detects one or more errors.	HCTL board error
6	HCTL Power Error	Power error for the HCTL board (24 V, 12 V, 5V).	HCTL board error
7	Fan Rotation Error	Fan rotation speed is slow.	<ul style="list-style-type: none"> • Fan error • HCTL board error
8	Hull Unit Operation Error	Hull unit malfunction.	<ul style="list-style-type: none"> • Hull unit error • Raise/lower encoder error • Raise/lower motor error • Raise/lower brake error

	Error	Meaning	Possible reason(s)
9	Motor Test Error (Tilt)*	Tilt motor self test detects one or more errors.	<ul style="list-style-type: none"> • Motor error • Motor cable disconnection/shortened/not connected correctly. • Mechanical error inside the soundome assembly. • HDRV board error • HCTL board error Note: Perform a disconnection and short circuit check for the motor cable.
10	Motor Driver Error (Rotate)	Motor driver IC is overheated, or overcurrent is detected.	<ul style="list-style-type: none"> • HDRV board error • Motor short circuit • Motor cable short circuit • Fan error Note: Perform a disconnection and short circuit check for the motor cable.
11	Motor Driver Error (Tilt)		
12	Resolver Driver Error (Rotate)	Resolver driver self test detects one or more errors.	HCTL board error
13	HCTL ROM/RAM Error	HCTL board self test at CPU startup detects one or more errors.	HCTL board error
14	Resolver Test Error (Rotate)	Resolver test detects one or more errors.	<ul style="list-style-type: none"> • Resolver disconnection/short circuit • Resolver cable disconnection/short circuit • HCTL board error Note: Perform a disconnection and short circuit check for the resolver.
15	Resolver Test Error (Tilt)		
16	Motor Test Error (Rotate)*	Rotation motor self test detects one or more errors.	<ul style="list-style-type: none"> • Motor error • Motor cable disconnection/shortened/not connected correctly. • Mechanical error inside the soundome assembly. • HDRV board error • HCTL board error Note: Perform a disconnection and short circuit check for the motor cable.

*: When the resolver has one or more errors, motor test shows error. Therefore, rectify the resolver error before rectifying the motor test error.

- When “5 Resolver Driver Error (Tilt)” or “15 Resolver Test Error (Tilt)” is detected, “9 Motor Test Error (Tilt)” occurs.
- When “12 Resolver Driver Error (Rotate)” or “14 Resolver Test Error (Rotate)” is detected, “16 Motor Test Error (Rotate)” occurs.

1. MOUNTING

Disconnection/short circuit check

When one or more of the following errors occur, perform a disconnection/short circuit check for the resolver or motor.

Occurred error	Check point
9 Motor Test Error (Tilt)	Perform a disconnection/short circuit check for the motor.
10 Motor Driver Error (Rotate)	
11 Motor Driver Error (Tilt)	
16 Motor Test Error (Rotate)	
14 Resolver Test Error (Rotate)	Perform a disconnection/short circuit check for the resolver.
15 Resolver Test Error (Tilt)	

- Disconnection/short circuit check for the motor
Remove the terminal block 734-209-FUR from the TB1 (HFLT board) in the control box, then measure resistance using a multimeter.

Terminal block 734-209-FUR

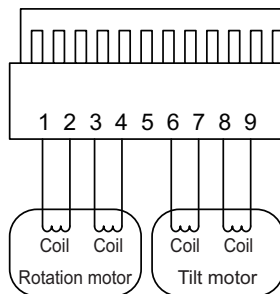

Measured point	Correct value	If the measured value is not correct value...
1-2, 3-4	10 to 30 Ω	Rotation motor or motor cable error
6-7, 8-9	10 to 30 Ω	Tilt motor or motor cable error
1-3	∞	Insulation failure in the rotation motor or motor cable.
6-8	∞	Insulation failure in the tilt motor or motor cable.
Between ground point (hull unit chassis) and pins 1 thru 4, 6 thru 9	∞	Insulation failure in the motor or motor cable.

- Disconnection/short circuit check for the resolver
Remove the terminal block 733-106-FUR and 733-110-FUR from the TB8 and TB10 in the control box, then measure resistance using a multimeter.

Terminal block 733-106-FUR

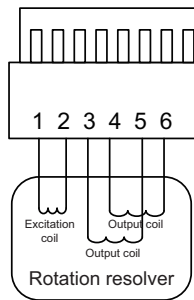

Measured point	Correct value	If the measured value is not correct value...
1-2	50 to 70Ω	Rotation resolver or resolver cable error When the extension box is used: Insulation failure in the extension box
3-5, 4-6	100 to 130Ω	
3-4	∞	
Between ground point (hull unit chassis) and pins 1 thru 6	∞	

Terminal block 733-110-FUR

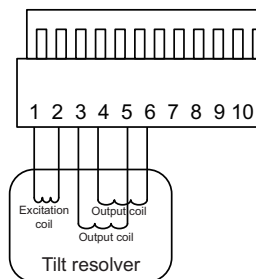

Measured point	Correct value	If the measured value is not correct value...
1-2	50 to 70 Ω	Tilt resolver or resolver cable error When the extension box is used: Insulation failure in the extension box
3-5, 4-6	100 to 130 Ω	
3-4	∞	
Between ground point (hull unit chassis) and pins 1 thru 6	∞	

1.3 Processor Unit

The processor unit can be installed on a deck or bulkhead.

Mounting considerations

Select a mounting location, keeping in mind the following points:

- Locate the unit out of direct sunlight and away from heat sources.
- Locate the unit away from places subject to water splash and rain.
- Select a mounting location considering the length of the cables to be connected to the unit.
- Select a location where shock and vibration are minimal.
- Be sure the mounting location is strong enough to support the weight of the unit.
- Referring to the outline drawings at the back of this manual, allow sufficient space for maintenance and service.
- A magnetic compass will be affected if the unit is placed too close to the magnetic compass. Observe the compass safe distances at the front of this manual to prevent interference to a magnetic compass.
- For the bulkhead installations, secure the unit so that the cable entrance faces downward.

1.3.1 Deck mount

1. Drill four pilot holes in the mounting location for mounting screws (M6 bolts or coach screws $\phi 6$), referring to the outline drawing at the back of this manual.
2. Secure the unit using the four mounting screws (supplied locally).

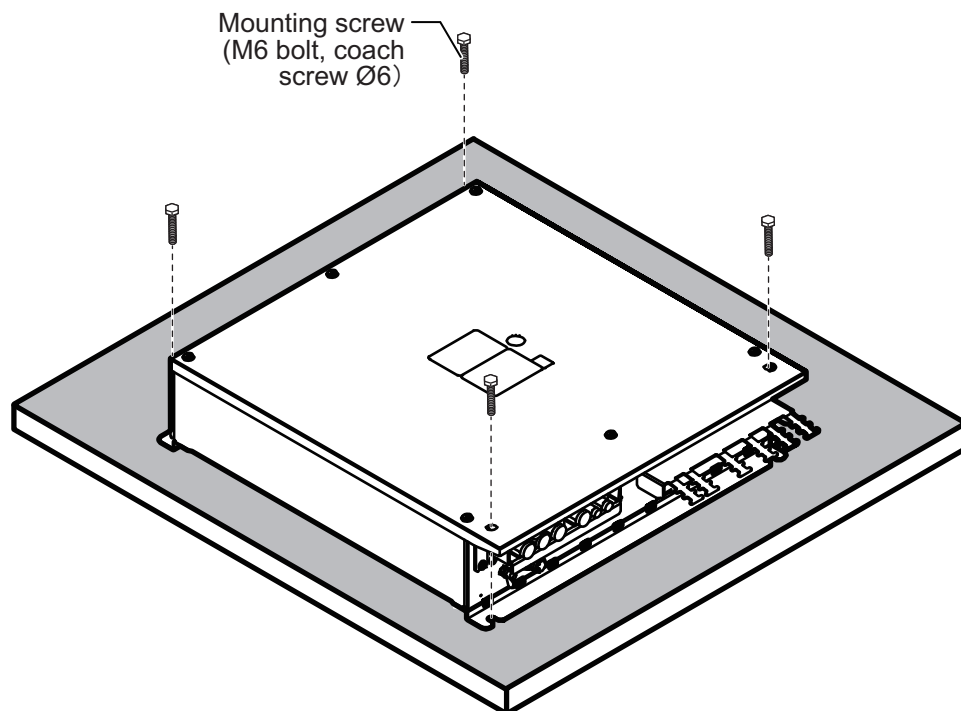

1. MOUNTING

1.3.2 Bulkhead mount

1. Drill four pilot holes in the mounting location for mounting screws (M6 bolts or coach screws $\phi 6$), referring to the outline drawing at the back of this manual.
2. Screw two mounting screws (supplied locally) into the lower pilot holes. Leave 5 mm of thread visible.
3. Set the notches of the unit onto the screws fastened at step 2.
4. Screw two mounting screws (supplied locally) into the upper fixing holes.
5. Fasten all screws tightly to secure the unit in place.

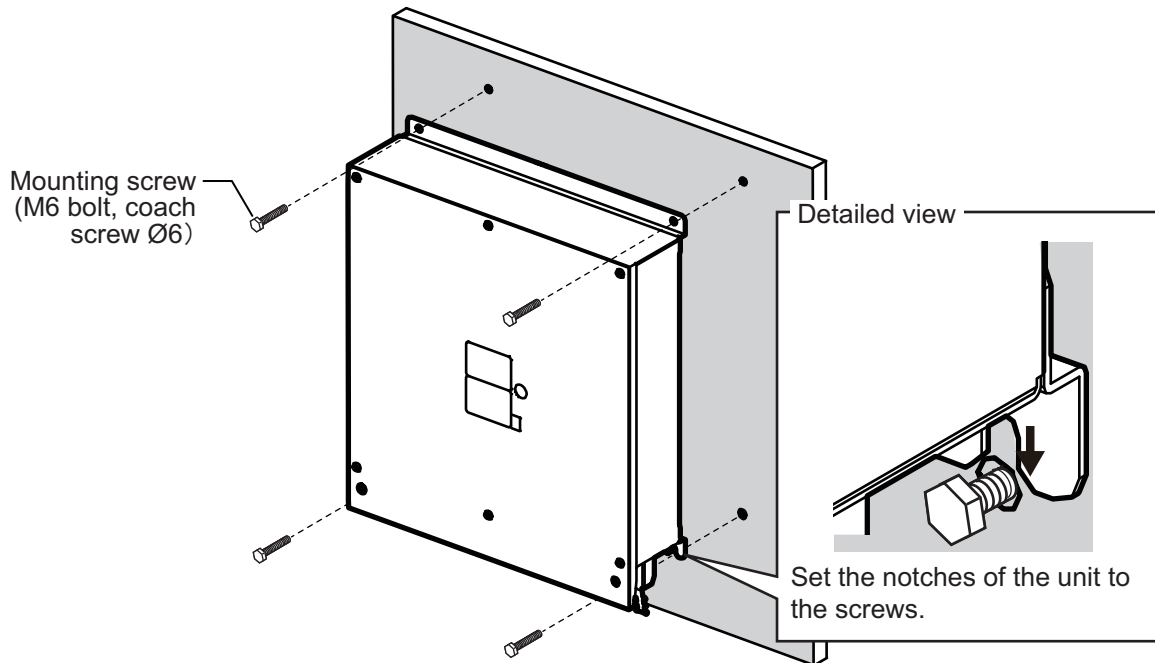

1.4 Control Unit

The control unit has following three mounting methods:

- Tabletop mounting: The unit is secured from the underside.
- Tabletop mounting with KB fixture: The unit is secured from the topside.
- Flush mounting

Mounting considerations

- Select a location where the unit can easily be operated.
- Locate the unit out of direct sunlight.
- Locate the unit away from places subject to water splash and rain.
- Select a location where shock and vibration are minimal.
- Select a mounting location considering the length of the cable.
- Referring to the outline drawings at the back of this manual, allow sufficient space for maintenance and service.
- A magnetic compass will be affected if the unit is placed too close to the magnetic compass. Observe the compass safe distances at the front of this manual to prevent interference to a magnetic compass.
- For flush installations, select a location where the surface is flat.

1.4.1 Tabletop mounting without KB fixture

1. Drill four pilot holes in the mounting location for stud bolts (M4×50), referring to the outline drawing at the back of this manual.
2. Attach a ground wire (IV-1.25sq, supplied locally) to the ground terminal at the bottom of the unit, then connect the other end of the ground wire with the ship's ground.
3. Insert four stud bolts (M4×20, supplied) to the bolt holes at the bottom of the unit.
Note: Insert the stud bolts manually. Do not use a tool to insert the bolts - the unit may become damaged.

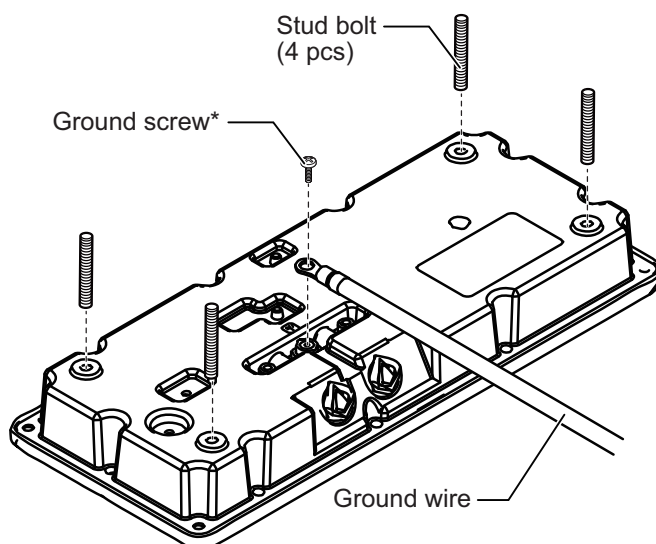

*: Use the screw that is preattached to the ground terminal.

4. Set the unit to the mounting location so that the stud bolts on the bottom of the unit are inserted to the pilot holes.
Note: Be careful to prevent the ground wire from being caught between the unit chassis and mounting surface.
5. Fasten the four wing nuts (supplied) to the stud bolts from the rear side of the mounting surface.

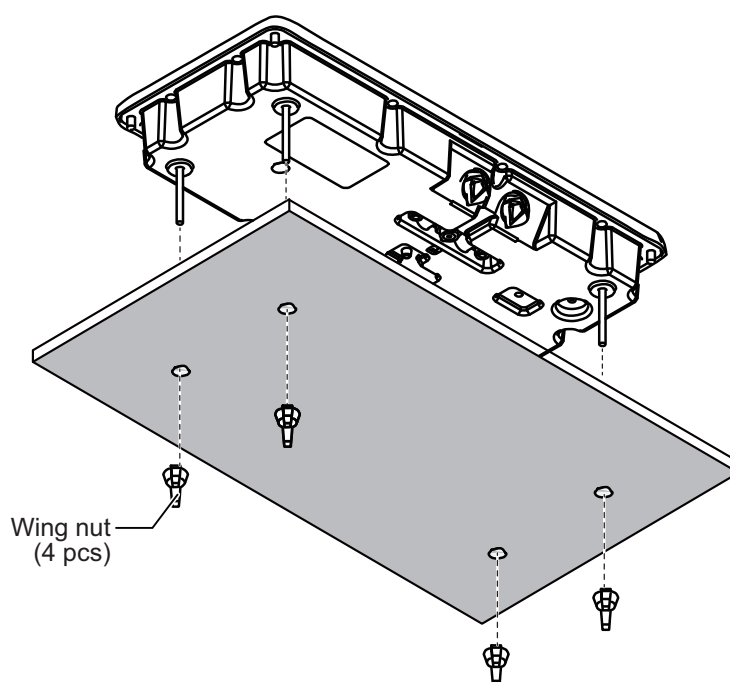

1. MOUNTING

1.4.2 Tabletop mounting with KB fixture

The control unit can be mounted with the KB fixture, which mounts the unit at an angle.

1. Drill four pilot holes in the mounting location for mounting screws, referring to the outline drawing at the back of this manual.
2. Secure the KB fixture (supplied) to the mounting location, using four self tapping screws ($\phi 5 \times 20$, supplied).

Note: Secure the KB fixture so that the cutout is located on the side farthest from the operator.

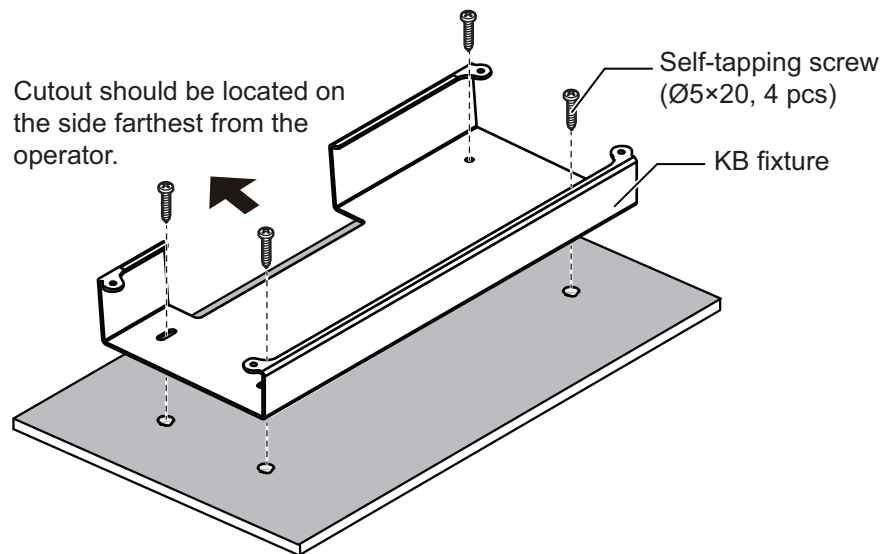

3. Attach a ground wire (IV-1.25sq, supplied locally) to the ground terminal at the bottom of the unit, then connect the other end of the ground wire with the ship's ground.

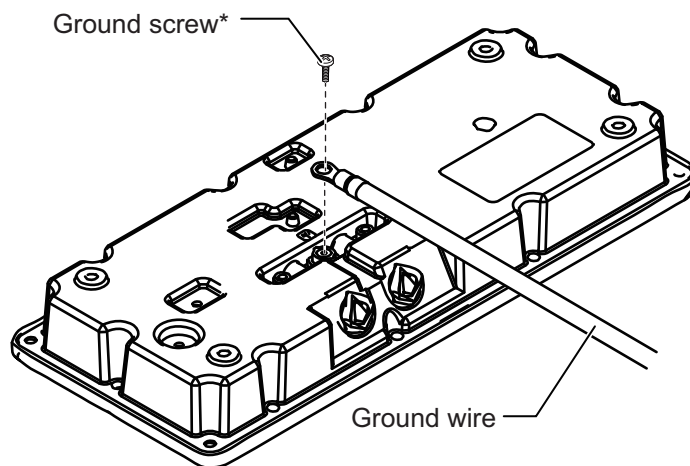

*: Use the screw that is preattached to the ground terminal.

4. Secure the control unit the KB fixture, using four binding screws (M5 \times 20, supplied).

- Attach four bolt hole caps (supplied).

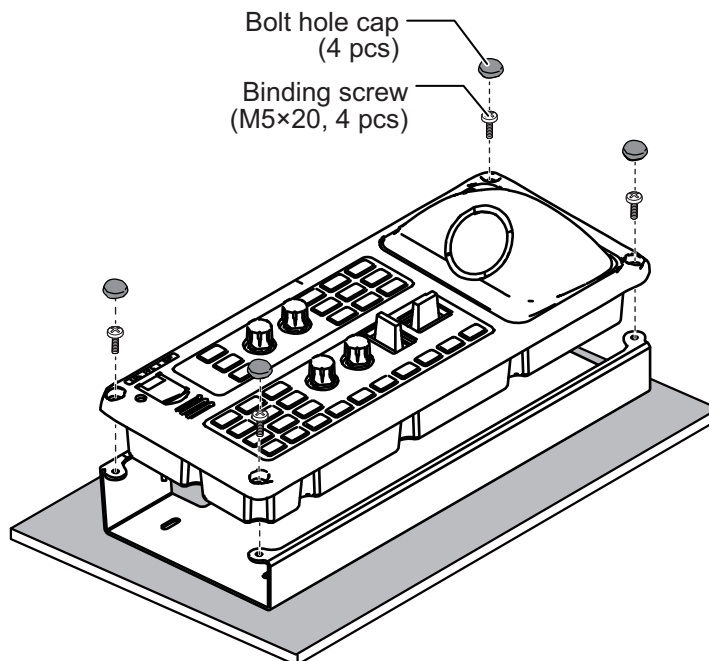

1.4.3 Flush mounting

Note: Be sure the mounting surface is flat.

- Referring to the outline drawing at the back of this manual, prepare a cutout, then drill four pilot holes in the mounting location.
- Attach a ground wire (IV-1.25sq, supplied locally) to the ground terminal at the bottom of the unit, then connect the other end of the ground wire with the ship's ground.

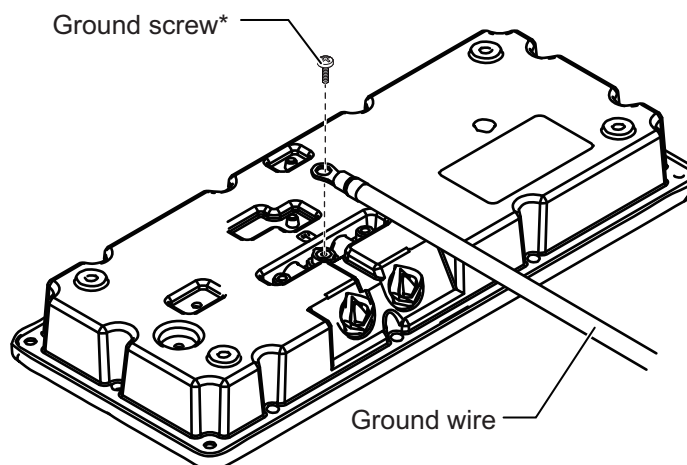

*: Use the screw that is preattached to the ground terminal.

- Set the unit to the cutout, then secure the unit with four self-tapping screws ($\phi 5 \times 20$, supplied).

1. MOUNTING

4. Attach four bolt hole caps (supplied).

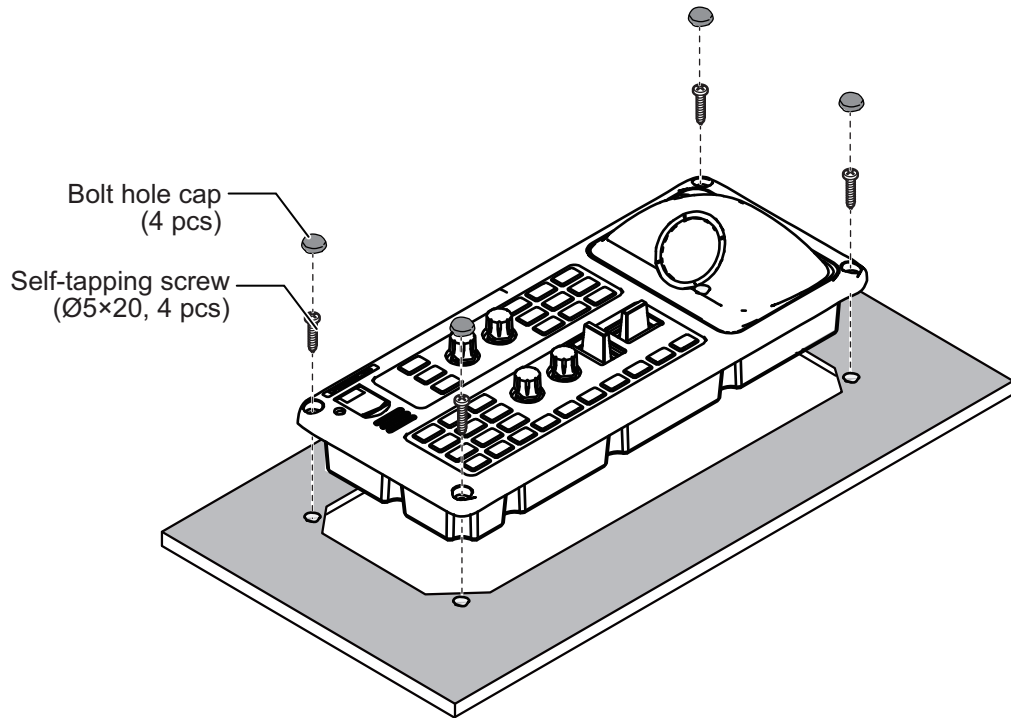

1.5 Transceiver Unit

The transceiver unit can be installed on a deck or bulkhead.

Mounting considerations

Select a mounting location, keeping in mind the following points:

- Locate the unit out of direct sunlight and away from heat sources.
- Locate the unit away from places subject to water splash and rain.
- Select a mounting location considering the length of the cables to be connected to the unit.
- Select a location where shock and vibration are minimal.
Reinforce the transceiver unit against vibration by stays extending from the eye-bolts on the top of the unit, as needed.
- Be sure the mounting location is strong enough to support the weight of the unit.
- Referring to the outline drawings at the back of this manual, allow sufficient space for maintenance and service.
- A magnetic compass will be affected if the unit is placed too close to the magnetic compass. Observe the compass safe distances at the front of this manual to prevent interference to a magnetic compass.
- For installation on a deck, use the bolt holes on the top and bottom of the unit.
If the three bolt holes on the top of the unit are not used, or mounting direction is not followed as shown in the following figure, the quality and performance may be reduced.

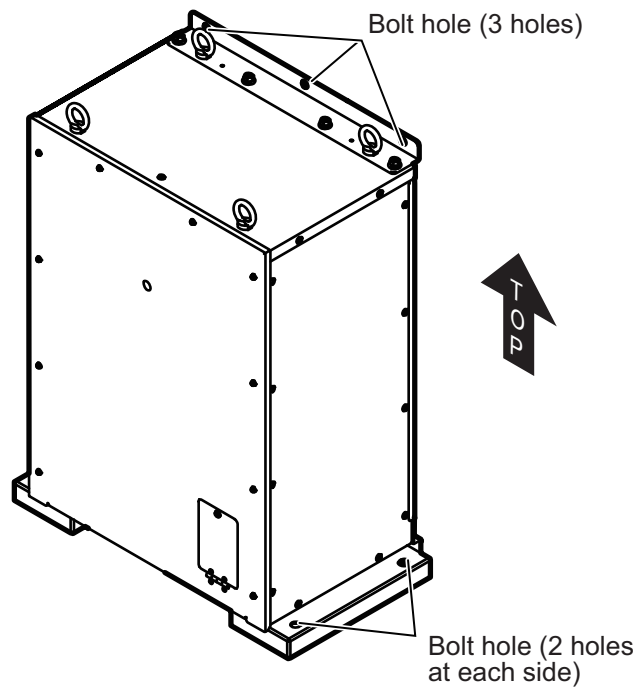

1.5.1 Deck mounting

1. Have the shipyard manufacture and fit a mounting base (SS400) at the mounting location.
2. Secure the unit to the mounting base, using four mounting bolts (M12, supplied locally).

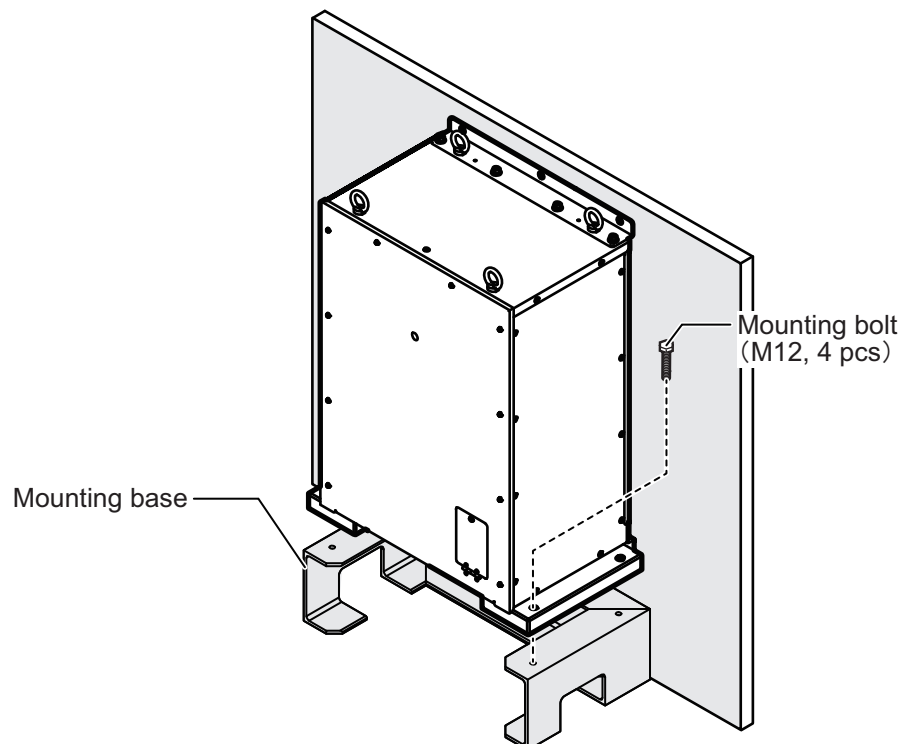

1. MOUNTING

3. Insert three mounting screws (M10 bolts or coach screw $\phi 10$, supplied locally) to the bolt holes on the top of the unit.

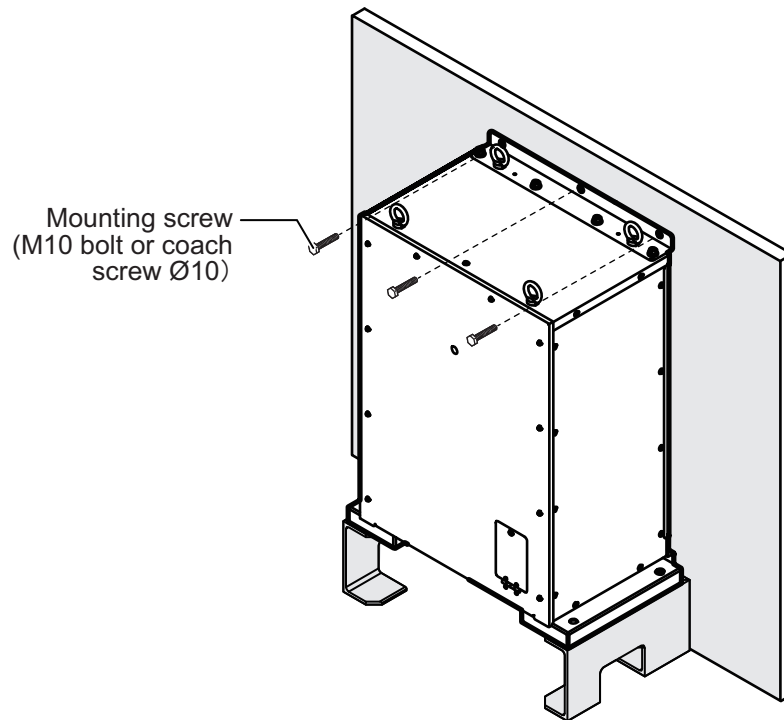

Note: Be sure to use the bolt holes on the top of the unit. When the back of the unit is not in contact with a bulkhead, prepare a stay or mounting base, referring to the following example.

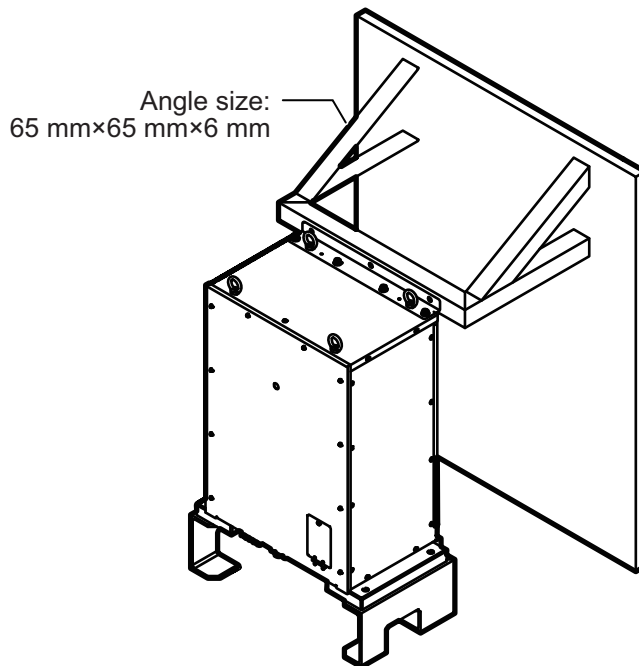

Example 1: Secure the unit with a stay

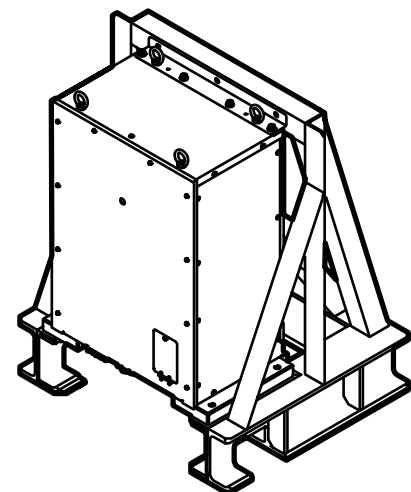

Example 2: Secure the unit on a dedicated mounting base

1.5.2 Bulkhead mounting

1. Remove the two mounting chassis on the bottom of the unit.

Note: Reattach upset screws to the bottom of the unit after removing the mounting chassis.

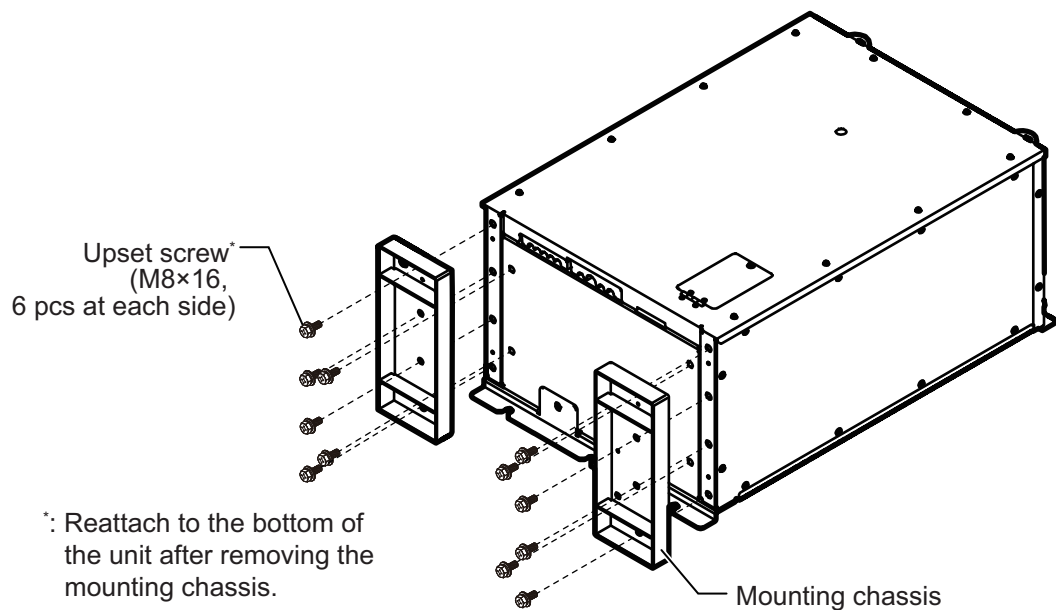

2. Drill six pilot holes in the mounting location for mounting screws (M10 bolts or coach screws $\phi 10$), referring to the outline drawing at the back of this manual.
3. Screw three mounting screws (supplied locally) into the lower pilot holes. Leave 5 mm of thread visible.
4. Set the notches of the unit onto the screws fastened at step 3.
5. Screw three mounting screws (supplied locally) into the upper fixing holes.
6. Fasten all screws tightly to secure the unit in place.

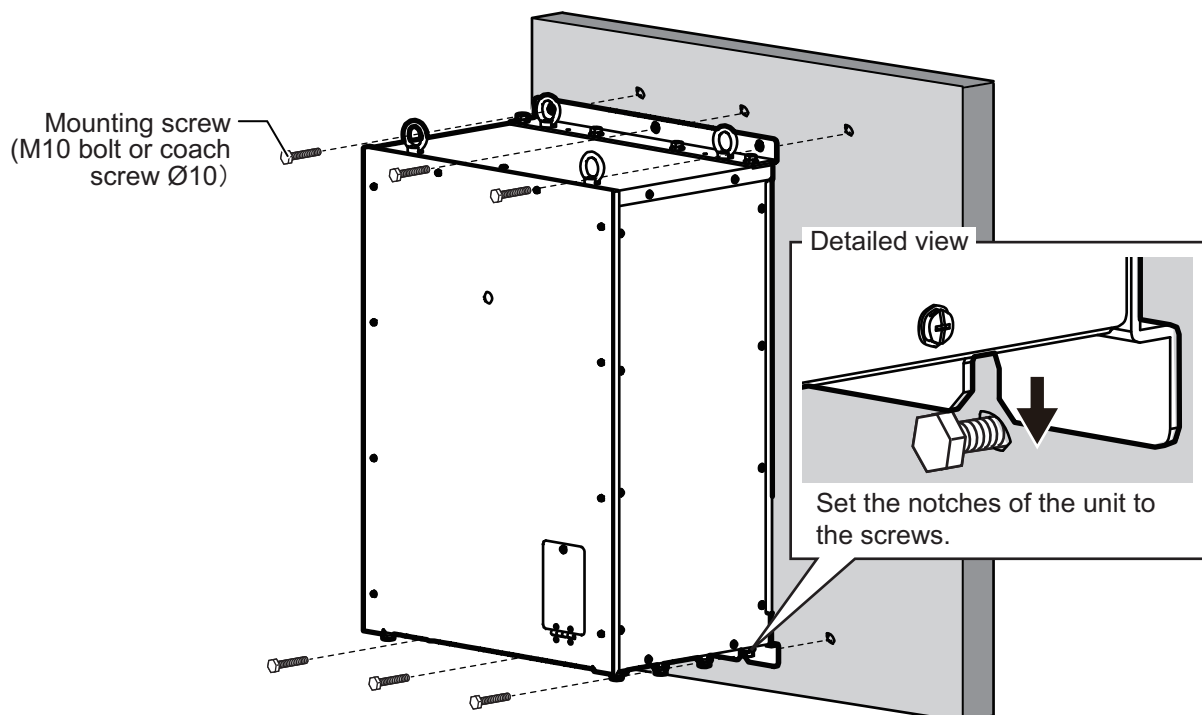

1.6 Matching Box

Install the matching box on the hull unit. The following two mounting directions are available for the matching box.

- Matching box cover faces to the port side.
- Matching box cover faces to the stern direction. This mounting direction is same as the control box.

Note: If the matching box is to be installed facing in the stern direction, change the mounting base positions.

Matching box cover facing to port

1. Screw two mounting screws (M10, supplied) into the lower fixing holes on the hull unit. Leave 5 mm of thread visible.
2. Set the notches of the unit onto the screws fastened at step 1.
3. Screw two mounting screws (M10, supplied) into the upper fixing holes.
4. Fasten all screws tightly to secure the unit in place.

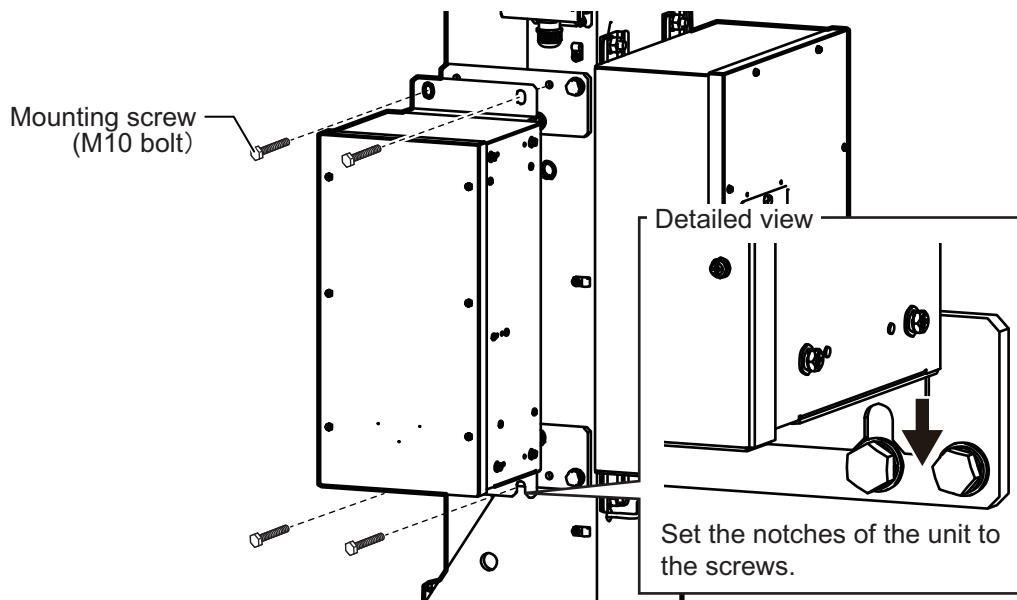

Matching box cover facing to stern

1. Unfasten the four upset screws (M5×12) to remove the two mounting bases from the bottom of the unit.

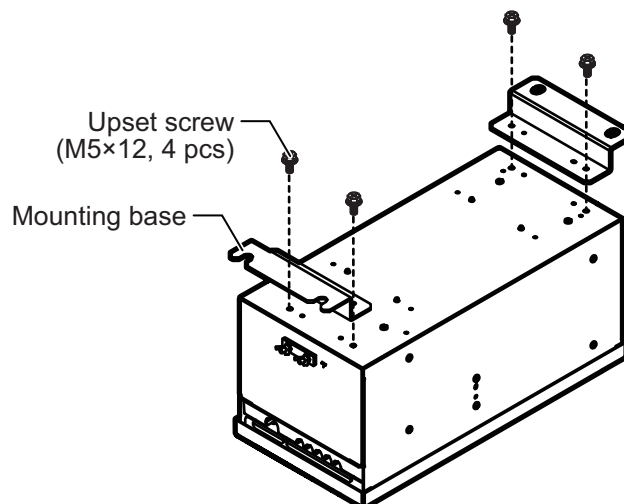

2. Remove the four binding screws (M5×12) from the right side of the unit, then insert the screws to the screw holes for the upset screws that were removed at step 1.
3. Attach the two mounting bases to the right side of the unit, using the upset screws that were removed at step 1.

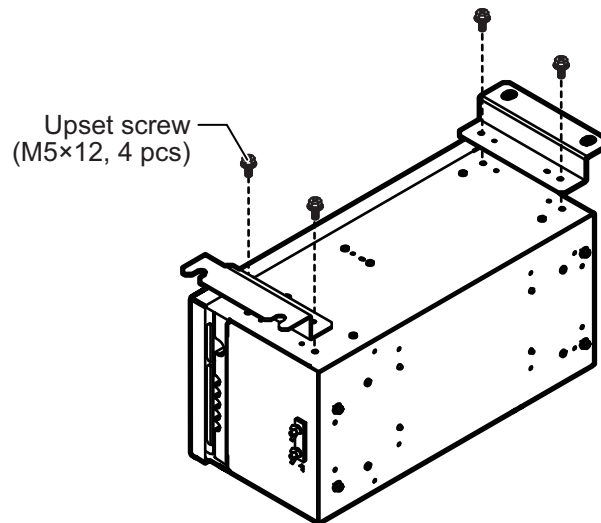

4. Screw the two mounting screws (M10, supplied) into the lower fixing holes on the hull unit. Leave 5 mm of thread visible.
5. Set the notches of the unit onto the screws fastened at step 4.
6. Screw the two mounting screws (M10, supplied) into the upper fixing holes.
7. Fasten all screws tightly to secure the unit in place.

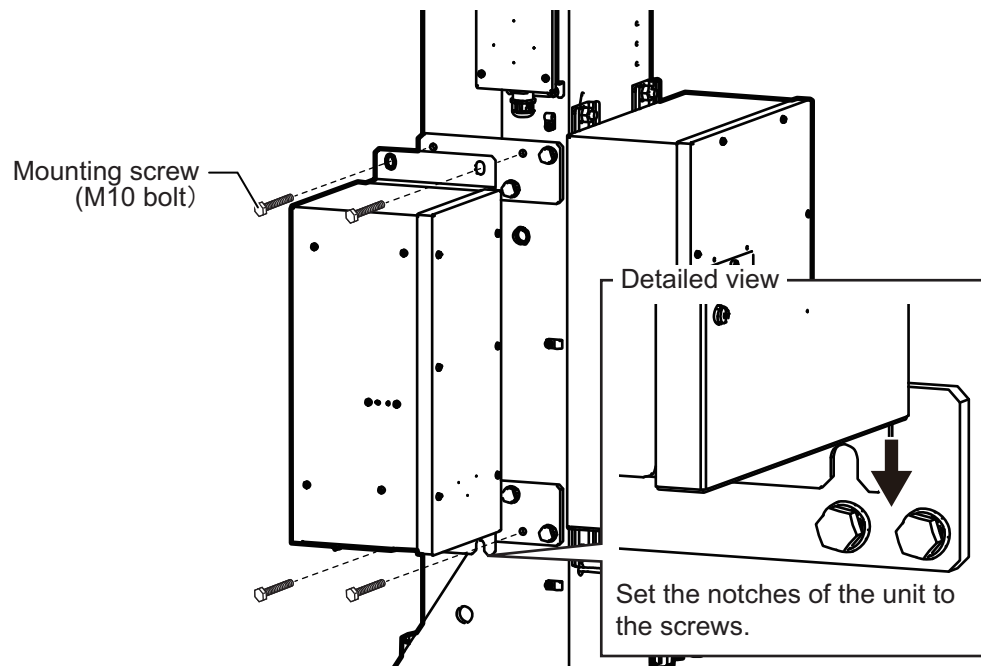

1.7 Control Box

The control box is preattached to the hull unit. When mounting the control box separately from the hull unit, use the optional extension box. The control box must be installed on a bulkhead.

Mounting considerations

Select a mounting location, keeping in mind the following points:

- Locate the unit out of direct sunlight and away from heat sources.
- Locate the unit away from places subject to water splash and rain.
- Select a mounting location considering the length of the cables to be connected to the unit.
- Select a location where shock and vibration are minimal.
- Be sure the mounting location is strong enough to support the weight of the unit.
- Referring to the outline drawings at the back of this manual, allow sufficient space for maintenance and service.
- A magnetic compass will be affected if the unit is placed too close to the magnetic compass. Observe the compass safe distances at the front of this manual to prevent interference to a magnetic compass.
- Secure the unit so that the cable entrance faces downward.

When mounting the control box separately from the hull unit

1. Unfasten the four hex nuts, spring washers and flat washers to remove the control box from the hull unit.

Note: The removed hex nuts, spring washers and flat washers are re-used when mounting the extension box to the hull unit.

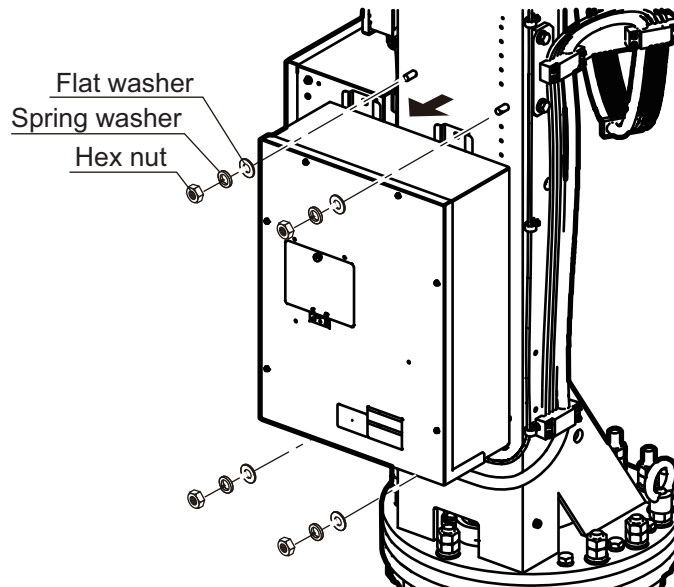

2. Drill four pilot holes in the mounting location for mounting screws (M10 bolt), referring to the outline drawing at the back of this manual.
3. Screw two mounting screws (supplied locally) into the lower pilot holes. Leave 5 mm of thread visible.
4. Set the notches of the unit onto the screws fastened at step 3.

5. Screw two mounting screws (supplied locally) into the upper fixing holes.
6. Fasten all screws tightly to secure the unit in place.

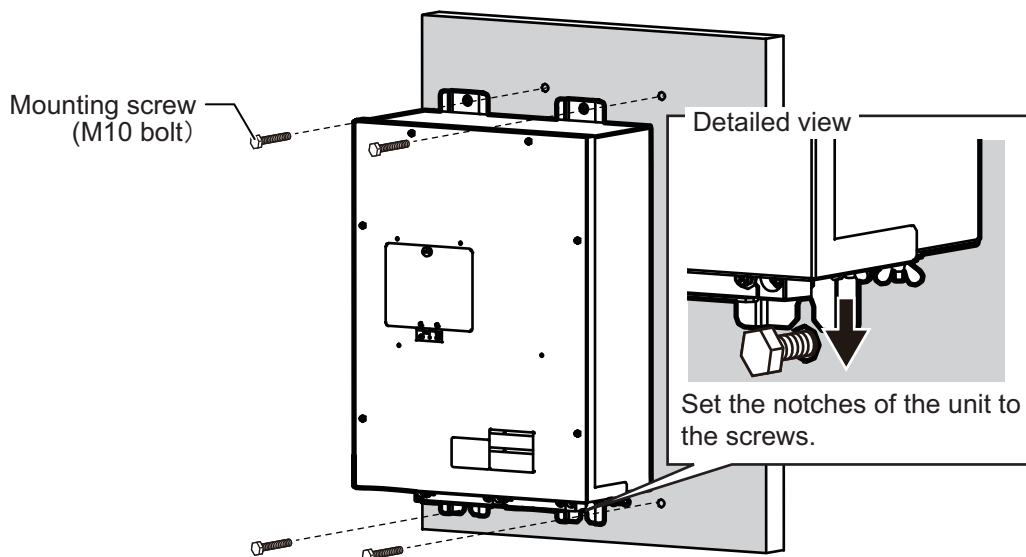

1.8 Extension Box

Install the extension box to the hull unit when mounting the control box separately from the hull unit. Remove the control box from the hull unit, then secure the extension box to the position where the control box was secured. For how to remove the control box from the hull unit, see section 1.7.

1. Set the extension box to the bolt on the rear (stern) side of the hull unit.
2. Secure the extension box to the hull unit, using four hex nuts, spring washers and flat washers.

Note: Use the hex nuts, spring washers and flat washers that were used for securing the control box.

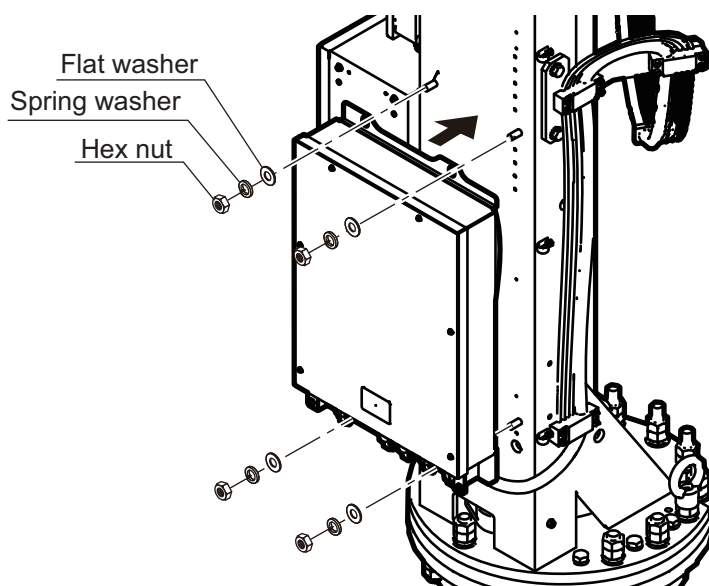

1.9 How to Fill the Dome with Sonar Oil

Fill the dome with sonar oil as shown below.

When the dome is not removed:

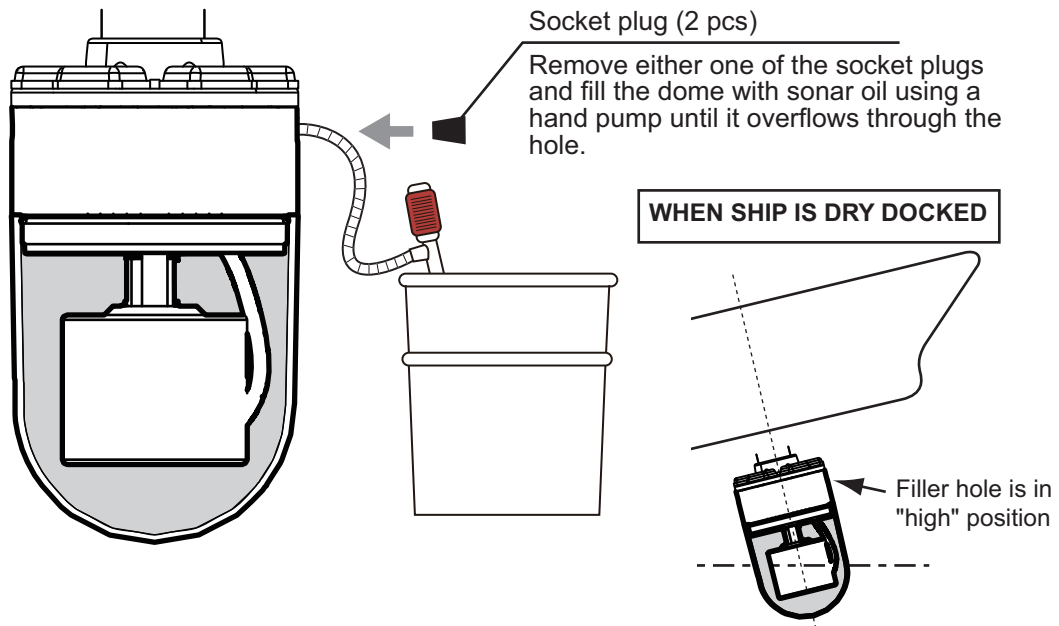

How to attach the socket plug

1. Remove the thread sealing tape from the socket plug.
2. Starting at the second thread, re-wrap three layers of sealing tape around the threads.
3. Pinch the threads between your thumb and a finger to fit the tape with the threads.
4. Reattach the socket plug.



Note: The sealing tape is not re-usable after you remove the socket plug. Always re-apply sealing tape after removing a socket plug.

When the dome is removed:

Fill the dome with sonar oil until the oil reaches the position indicated in the figure to the right.

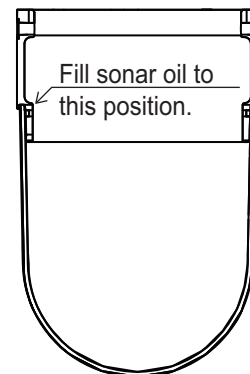

Note 1: When the ship is dry docked, drain antifreeze from dome when temperature is lower than -20°C . Failure to do so can damage the dome.

Note 2: After filling the sonar oil, record the date that you filled sonar oil, referring to section 3.16.

Note 3: If sonar oil comes into contact with the dome surface, clean the dome with a surfactant. Sonar oil can adversely affect the acoustic capabilities of the dome if left on the surface.

Note 4: When the dome is painted to keep marine life off the transducer, observe the following precautions.

- Use only anti-foulant “SEATENDER20” or SEA GRANDPRIX 660 HS (Manufacture: Chugoku Marine Paint Co. Ltd., Japan).
- Mask the metal part to prevent contact with anti-foulant. However, the underside of the metal part can be painted with anti-foulant.

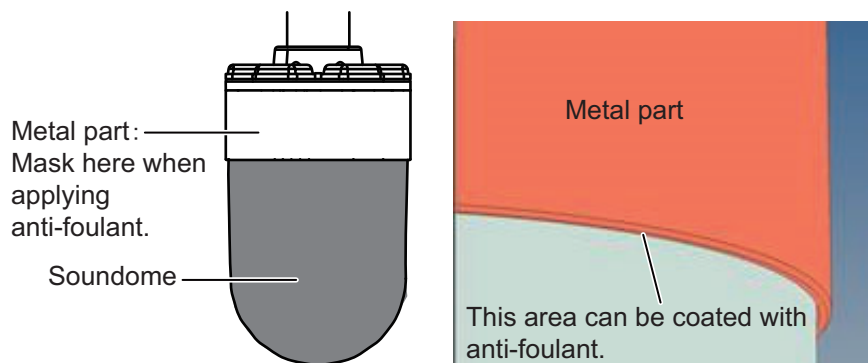

1.10 Installing to an Existing Retraction Tank

To install the hull unit to the existing retraction tank for the CSH series, use the optional attachment kit or attachment flange.

- When tank length does not need to be extended, use the attachment kit.
- When tank length needs to be extended, use the attachment flange.

1.10.1 When tank extension is not required

When the tank length does not need to be extended for installation to the existing retraction tank, use the optional attachment kit (type: OP10-56).

The items included in the attachment kit are listed in the following table.

Name	Type	Code No.	Qty	Remarks
Gasket	SHG-0003-1	100-038-571-10	1	
O-ring	CO 0117A (P355)	000-158-976-10	1	
Insulation Packing	MS-1000-68-1	100-347-611-10	16	
Stainless Steel Wire	TSW-12 *1M*	000-179-538-10	1	Used to adjust the tank guide position (see section 1.10.3).

Note: Remove marine life (barnacles, etc.) from the existing retraction tank before installing the hull unit.

1. Clean the flange and O-ring groove of the retraction tank (welded to hull). Use waste cloths moistened with ethyl alcohol.
2. Coat the O-ring and O-ring groove with lithium grease, then place the O-ring in its groove on the tank flange.
3. Lay the gasket on the top of the tank flange.

1. MOUNTING

4. Orient the hull unit so that the bow mark (inscribed) on its flange points toward the ship's bow.

Note: If the bow mark on the hull unit flange is not facing the ship's bow, rotate the transducer so that the bow mark on the transducer points toward the ship's bow (see section 1.2.9).
5. Confirm the following points and place the hull unit on the tank.
 - Clean the flange platform.
 - Wipe the undersurface of the hull unit flange with clean waste cloths.
 - Keep the O-ring in its groove.
 - Place the hull unit so that the rollers on the tank guide do not contact the weld bead on the retraction tank. If the rollers contact the weld bead, adjust the tank guide position (see section 1.10.3).
6. Coat the threads of the bolts with a slight amount of lithium grease to prevent scorching, then secure the hull unit to the retraction tank, referring to the following figure.

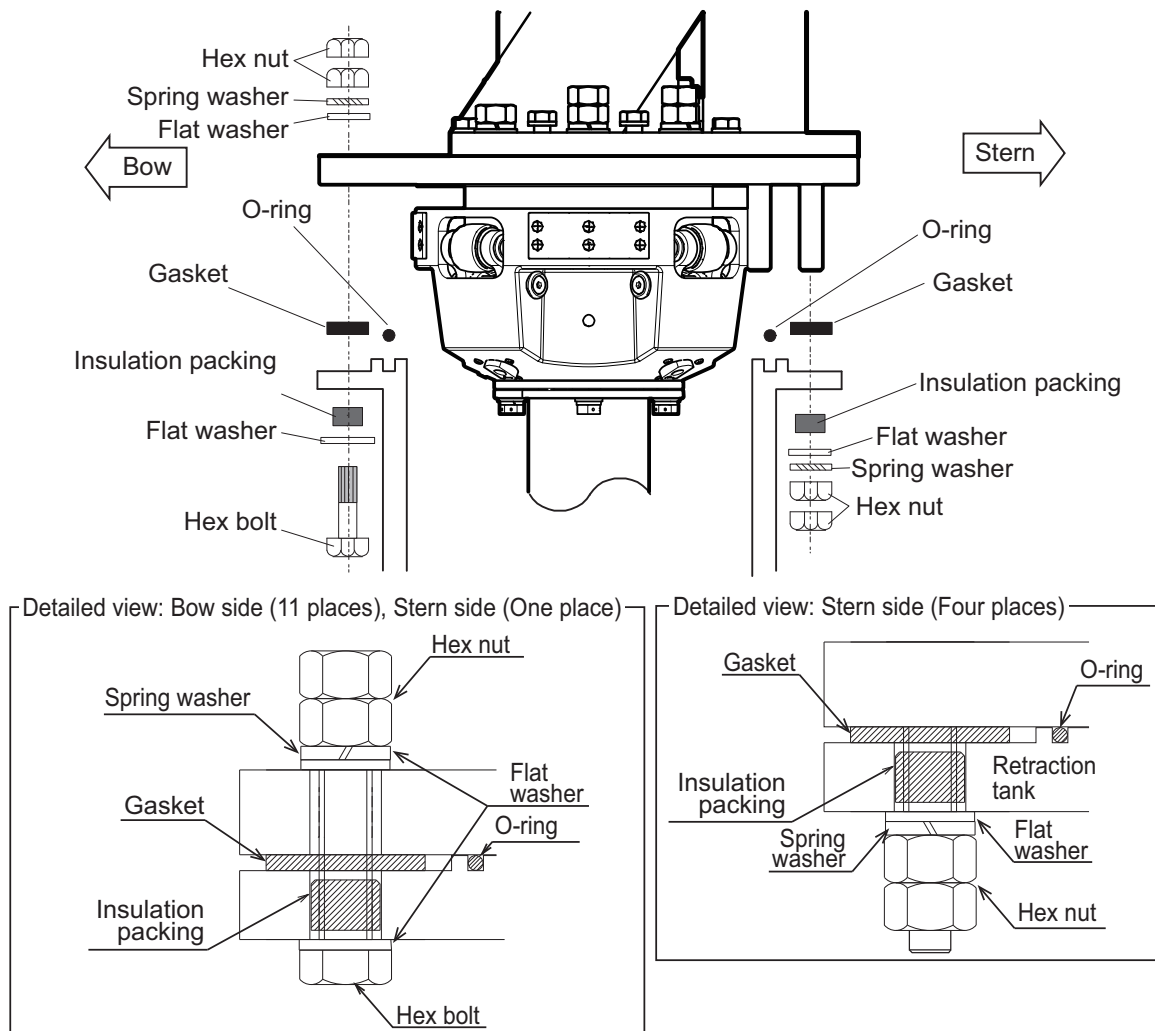

7. Lower the transducer, then confirm that the rollers on the tank guide are not projecting from the retraction tank.

Tank guide must be positioned 30 mm inside from the bottom of the retraction tank.

Note: The position for the lower limit switch can be raised 100 mm by using the bolt holes on the flange assembly.

1.10.2 When tank extension is required

If you need to extend the tank length when installing to an existing retraction tank, use the optional attachment flange. Select the correct attachment flange from the following table, using the length of the pre-installed tank to determine the raising height.

Name	Type	Raising height
Attachment Flange	OP10-50	150 mm
	OP10-51	250 mm
	OP10-52	350 mm
	OP10-53	450 mm

Note: Do not use multiple attachment flanges to a retraction tank.

The items supplied with the attachment flange are listed in the following table.

Name	Type	Code No.	Qty	Remarks
Attachment Flange	10-090-5552	100-424-770-10	1	For OP10-50
	10-090-5554	100-424-780-10		For OP10-51
	10-090-5555	100-424-790-10		For OP10-52
	10-090-5556	100-424-800-10		For OP10-53
O-ring	CO 0117A (P355)	000-158-976-10	1	
Hex Bolt	M20×120 SUS304	000-162-825-10	16	Not included for OP10-50.
Gasket	SHG-0003-1	100-038-571-10	1	
Insulation Packing	MS-1000-68-1	100-347-611-10	16	
Spring Washer	M20 SUS304	000-167-401-10	16	
Flat Washer	M20 SUS304	000-167-452-10	32*	
Hex Nut	M20 SUS304	000-167-476-10	32	
Stainless Steel Wire	TSW-12 *1M*	000-179-538-10	1	Used to adjust the tank guide position (see section 1.10.3).

*: 16 flat washers are included with OP10-50.

Note: Remove marine life (barnacles, etc.) from the existing retraction tank before installing the hull unit.

1. Clean the flange and O-ring groove of the retraction tank (welded to hull). Use waste cloths moistened with ethyl alcohol.
2. Coat the O-ring and O-ring groove with lithium grease, then place the O-ring in its groove on the tank flange.
3. Lay the gasket on the top of the tank flange.
4. Confirm the following points and place the attachment flange on the tank.
 - Clean the flange platform.
 - Wipe the undersurface of the attachment flange with clean waste cloths.
 - Keep the O-ring in its groove.

1. MOUNTING

- Coat the threads of the bolts with a slight amount of lithium grease to prevent scorching, then secure the attachment flange to the retraction tank, referring to the following figure.

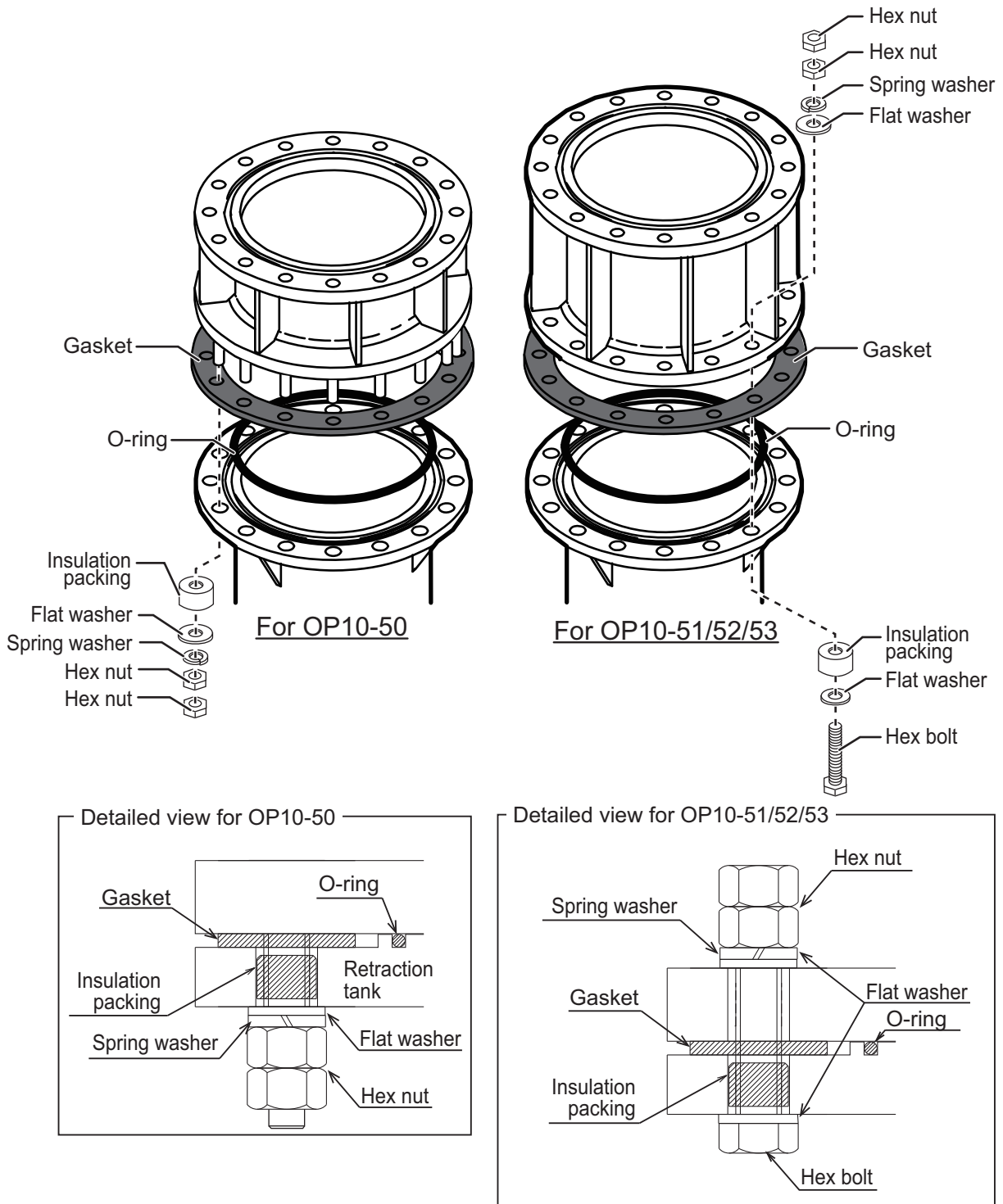

- Orient the hull unit so that the bow mark (inscribed) on its flange points toward the ship's bow.

Note: If the bow mark on the hull unit flange is not facing the ship's bow, rotate the transducer so that the bow mark on the transducer points toward the ship's bow (see section 1.2.9).

7. Place the hull unit on the attachment flange (retraction tank).
Note: Place the hull unit so that the rollers on the tank guide do not come into contact with the weld bead on the retraction tank. If the rollers contact the weld bead, adjust the tank guide position (see section 1.10.3).
8. Coat threads of the bolts with a slight amount of lithium grease to prevent scorching, then secure the hull unit to the retraction tank, referring to the following figure.

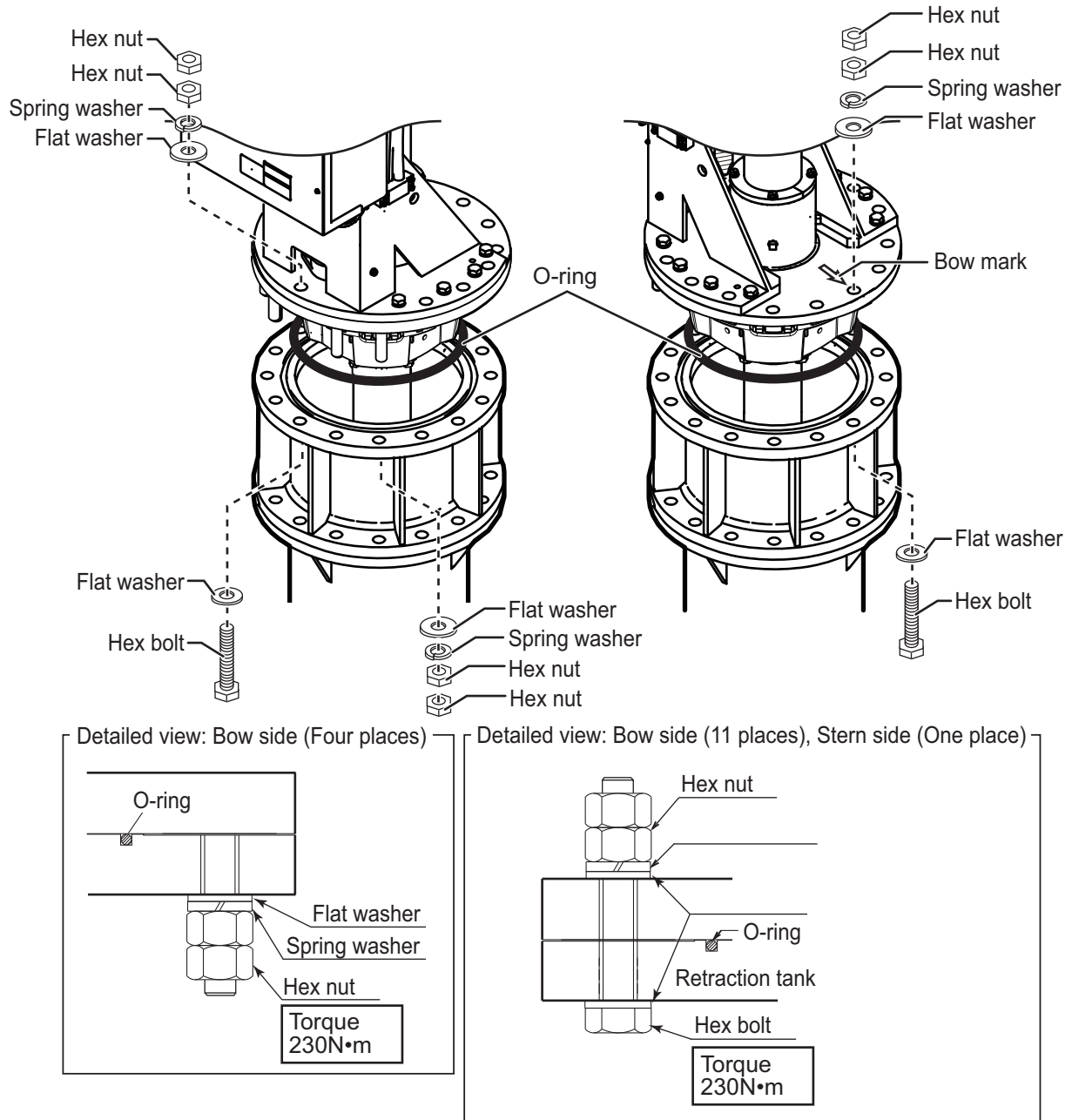

9. Lower the transducer, then confirm that the rollers on the tank guide are not projecting from the retraction tank.
 Tank guide must be positioned 30 mm inside from the bottom of the retraction tank.

Note: The position for the lower limit switch can be raised 100 mm by using the bolt holes on the flange assembly.

1.10.3 Adjusting the tank guide position

If the rollers on the tank guide come into contact with the weld bead on the retraction tank, rotate the tank guide to adjust the position of the rollers.

1. Lower the transducer manually.

Note: For how to lower the transducer manually, follow the procedure indicated on the label at the top of the hull unit.

2. Insert four bolts (M10×80, supplied locally) in the holes on the bottom of the tank guide to push the tank guide rollers inwards.

Note: Steel bolts are recommended to prevent scorching.

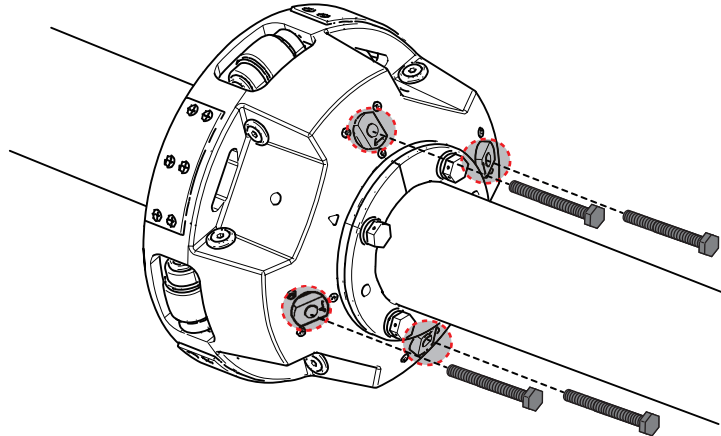

3. Remove the four bolts on the bottom of the tank guide and the connected stainless steel wires.

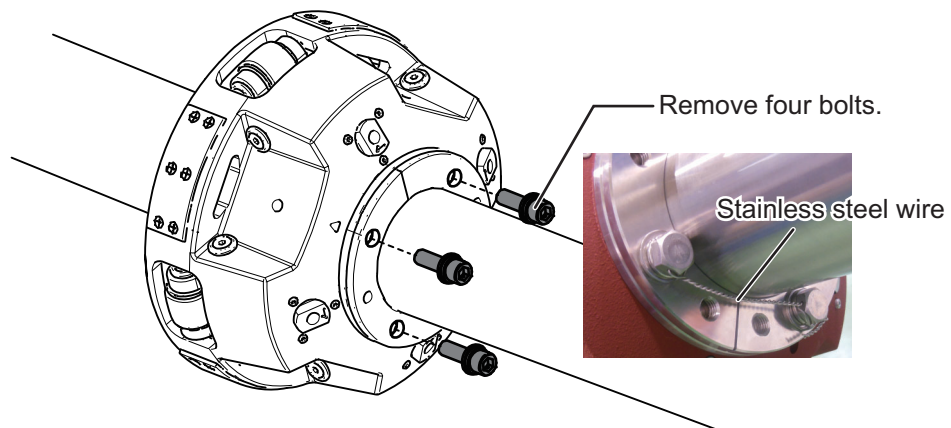

- Insert two of the bolts removed at step 3 in the locations indicated in the figure below, to raise the tank guide. Raise the tank guide until it can be rotated.

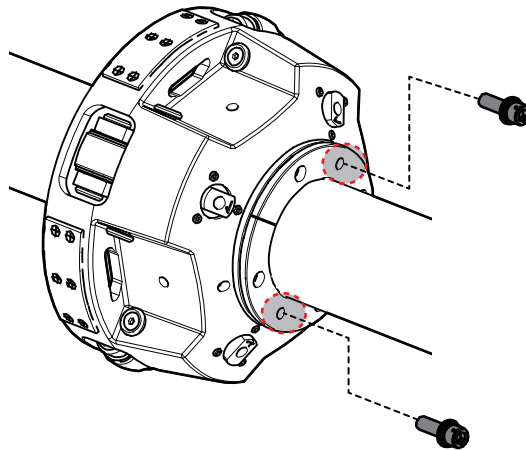

- Rotate the tank guide until the rollers on the tank guide do not come into contact with the weld bead on the retraction tank.
- Remove the two bolts inserted at step 4
- Reinsert the four bolts removed at step 3 and attach stainless wires* as shown below.

*: Use the stainless steel wire included in the attachment flange or attachment kit.

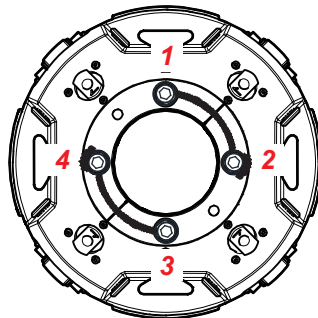

Attach the stainless wire between bolts **1** and **2**, **3** and **4**. Start at bolts **1** and **3**.

- Insert the stainless wire to the hole on the side of the hex socket head bolt.

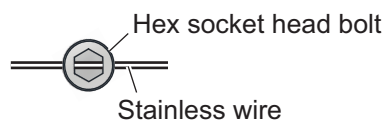

- Twist the wire in the clockwise direction.



- Insert the wire to the next bolt, then twist the wire in the counterclockwise direction.

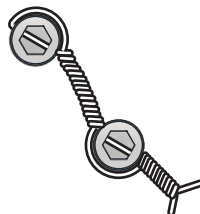

- Cut the wire, leaving approx. 20 mm loose. Wrap the loose wire around the last bolt.

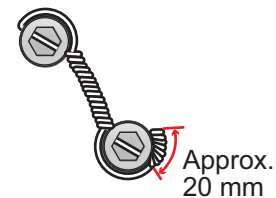

- Remove the four bolts inserted at step 2.
- Raise the transducer.

1. MOUNTING

This page is intentionally left blank.

2. WIRING

The illustration on this page shows the general connection of the FSV-75. For detailed information, see the interconnection diagram. Many of the cables mentioned are JIS (Japanese Industrial Standards) cables. If not available locally, use the equivalent. See the cable guide in the Appendix for how to select equivalent cables.

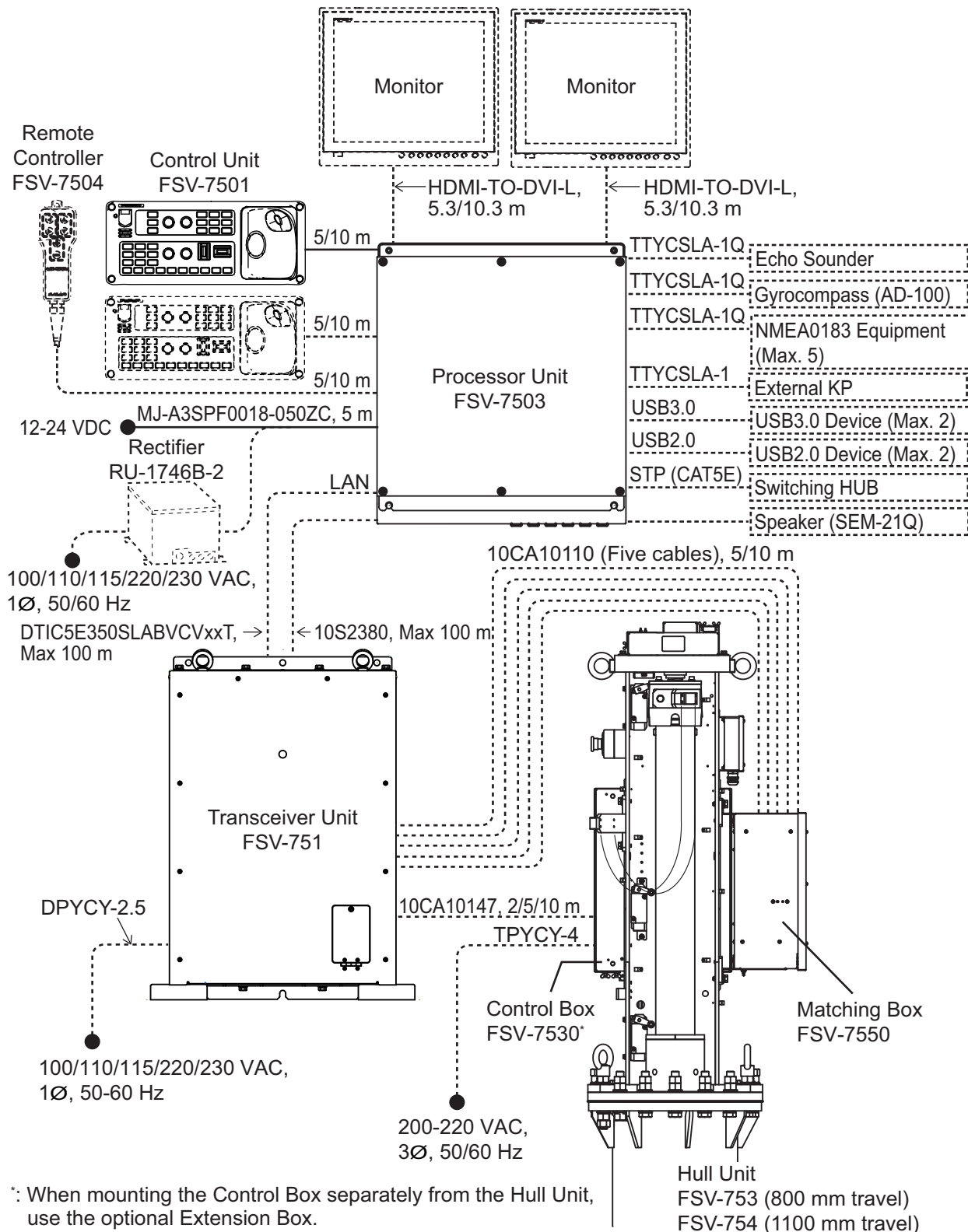

Notes for network construction

- The transceiver unit must be directly connected to the processor unit. Do not use a network hub for this Ethernet connection.
- When you need 10 m or more cable for the control unit and monitor unit, prepare a commercial adapter.
- For configurations with two monitor units, make sure the resolution is the same for both monitors. Both monitors must also be landscape oriented. The FSV-75 cannot display images correctly if the monitors do not meet these requirements.
- Do not cut the HDMI cable between the monitor unit and processor unit.
- If the cable between the monitor unit and processor unit is disconnected and reconnected while the system is powered, the FSV-75 may display images incorrectly. Restart the system if this occurs.
- For configuration with either the MU-190 or MU-190-HD monitor units, monitor brilliance can be adjusted from the control unit. To use this feature, connect a USB cable between the monitor unit and the processor unit. The USB cable must be connected directly between the units; do not use a USB hub.
- For configurations with dual monitors, connect the main monitor to the HDMI1 port and the sub monitor to the HDMI2 port.

Transducer cable

If the transducer is removed from the hull unit while installing the hull unit, reattach the transducer and route the transducer cables as shown in the following figure.

NOTICE

Route the cables so their lengths are as indicated in the figure below.
Failure to observe the lengths may damage or sever cables.

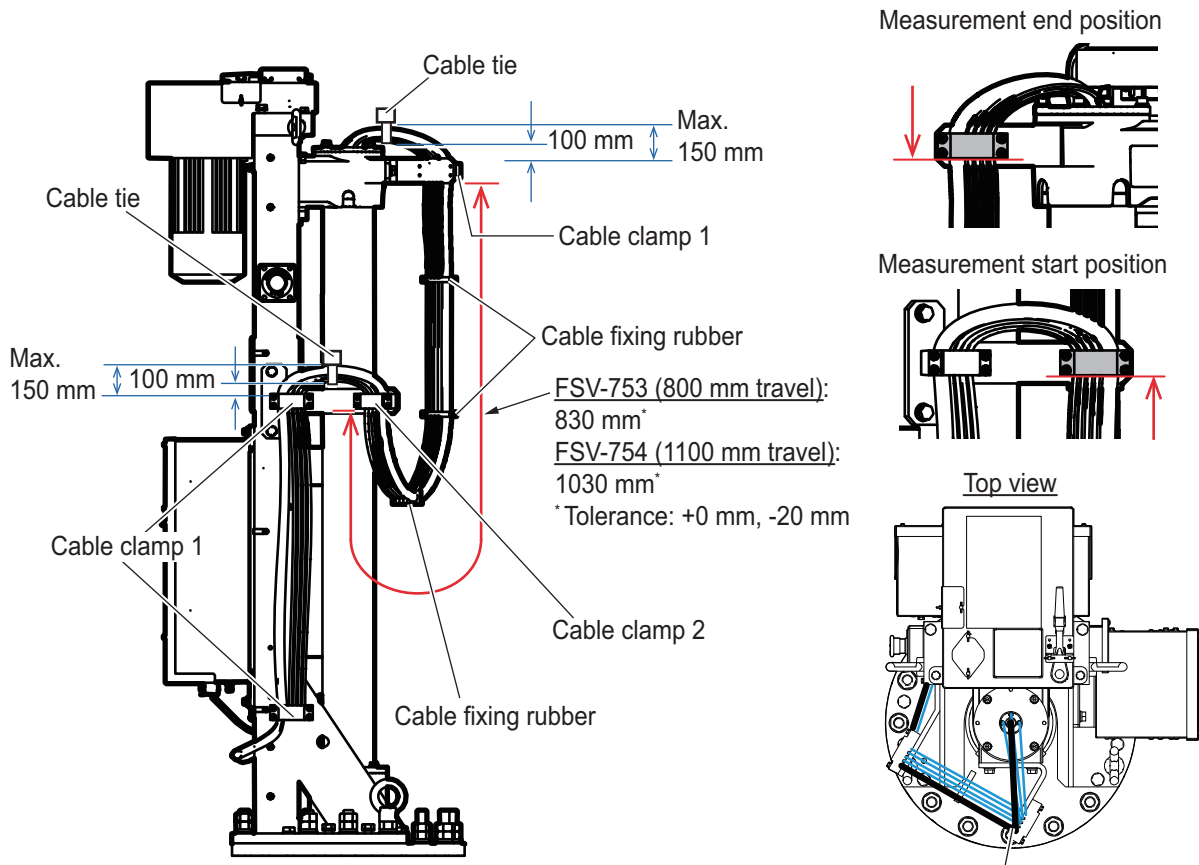

Cables must be routed with the thickest cable farthest out.

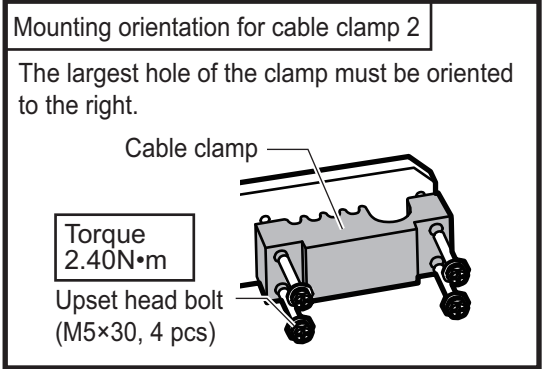
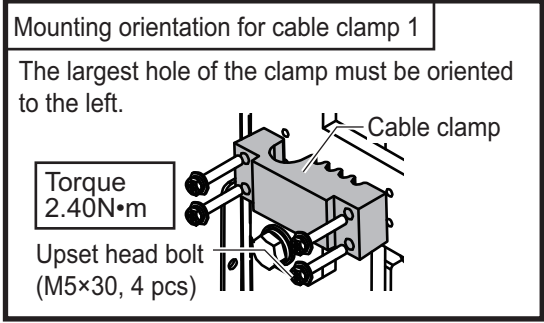

2.1 Processor Unit

2.1.1 Connectors

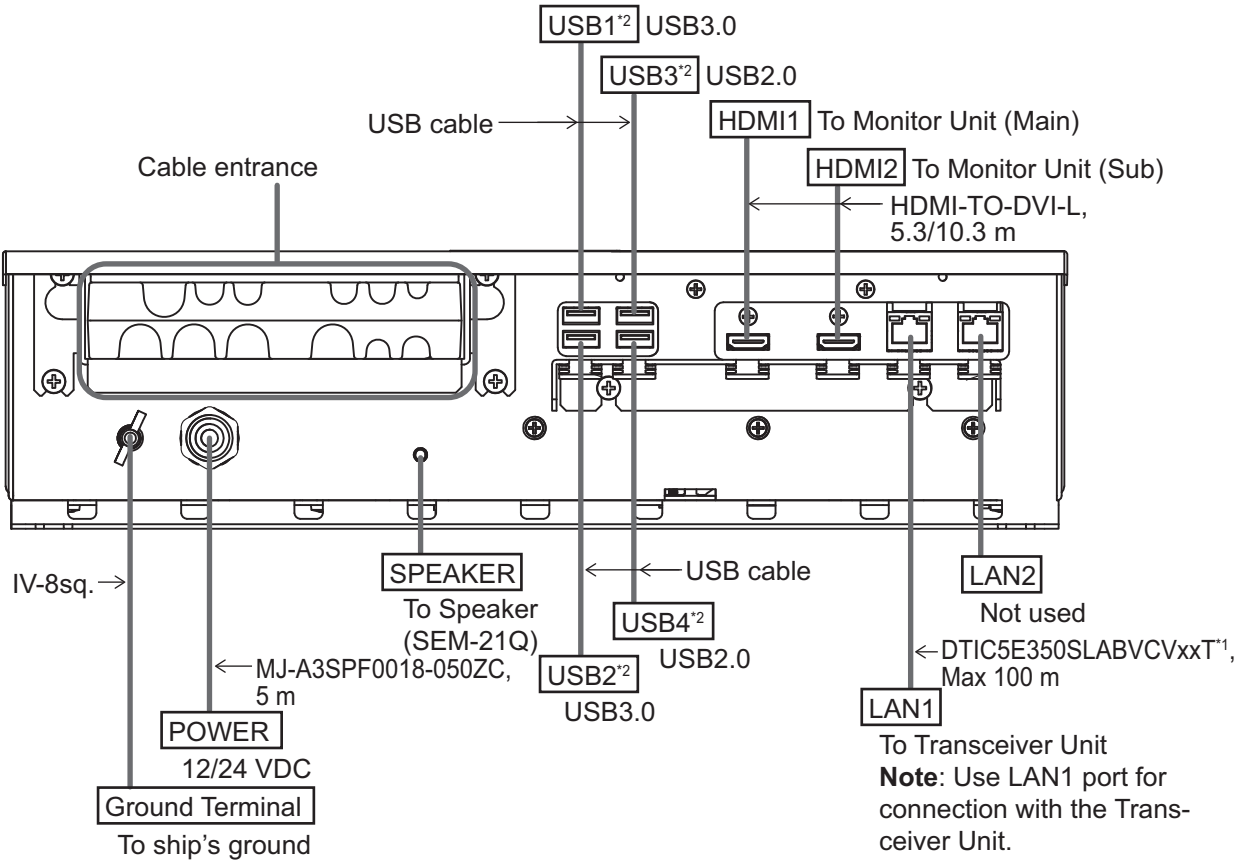

*1: Fabricate the cable referring to section 2.1.3.

*2: To connect a USB device, use the lower USB port first.

Secure the USB, HDMI and LAN cables to the cable clamp with a cable tie (supplied locally). For the USB cables, use two cable ties to secure the cable.

Note: The cable clamp can be adjusted to allow larger connectors, such as USB or HDMI, to be connected.

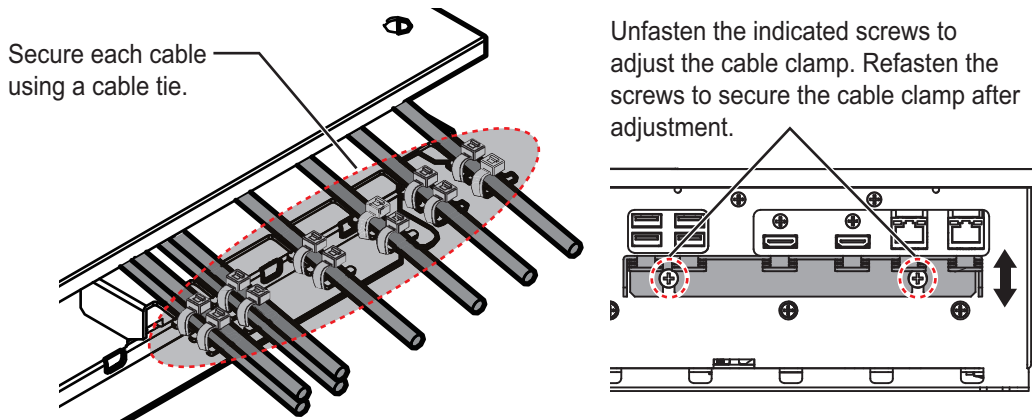

2.1.2 Internal wiring and cable clamp position

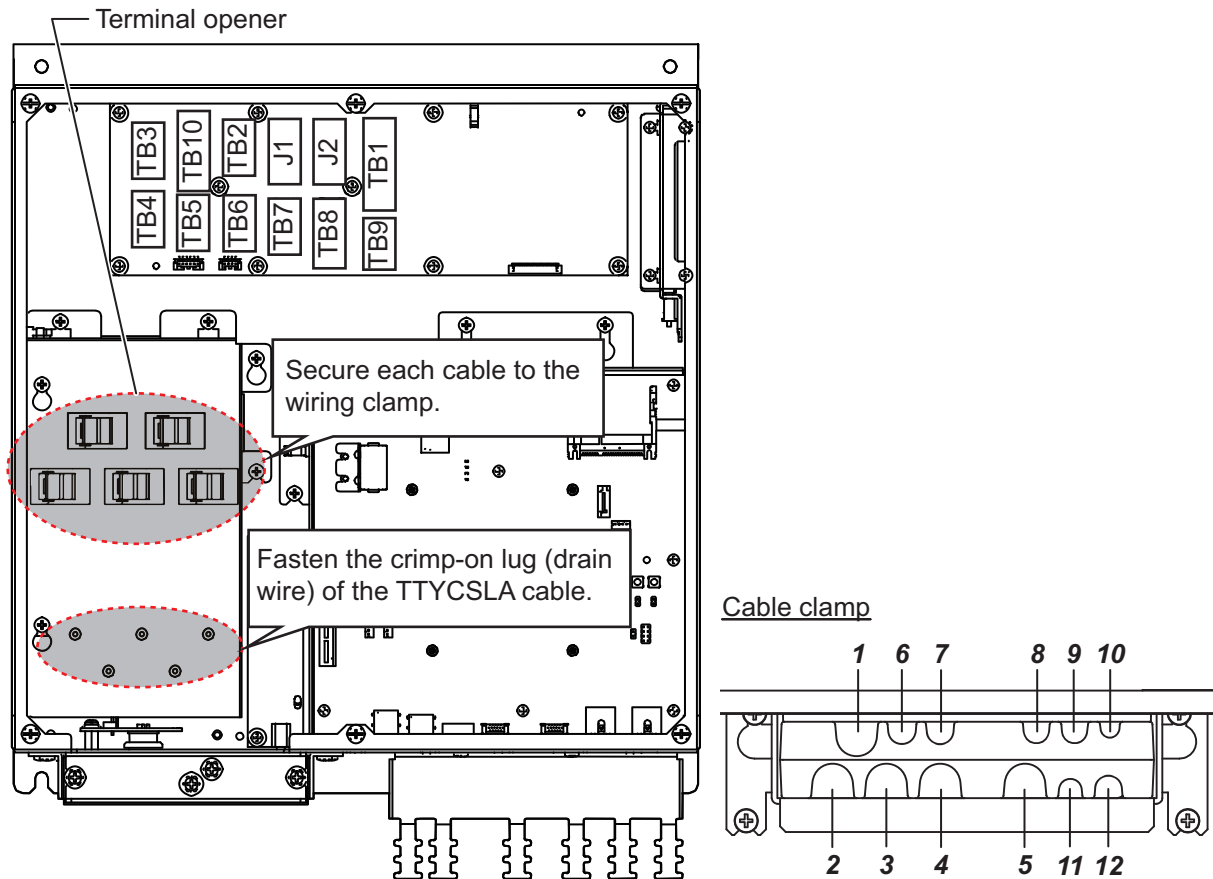

Clamp position	Connect to	Cable from	Cable
1	TB3	NMEA0183 equipment	TTYCSLA-1Q* ¹
2	TB4		
3	TB5		
4	TB6		
5	TB7		
6	TB10	Transceiver unit	10S2380* ¹
7	TB2	Gyrocompass (AD-10)	TTYCSLA-1Q* ¹
8	J1	Control unit	-
9	J2	Control unit	-
10	TB1	Remote controller, external switch* ²	-
11	TB8	External KP* ³	TTYCSLA-1* ¹
12	TB9	External echo sounder	TTYCSLA-1Q* ¹

*¹: Fabricate the cables referring to section 2.1.3.

*²: To connect an external switch, see section 2.1.5.

*³: To connect an external KP, see section 2.1.6.

2.1.3 Cable fabrication

10S2380 cable

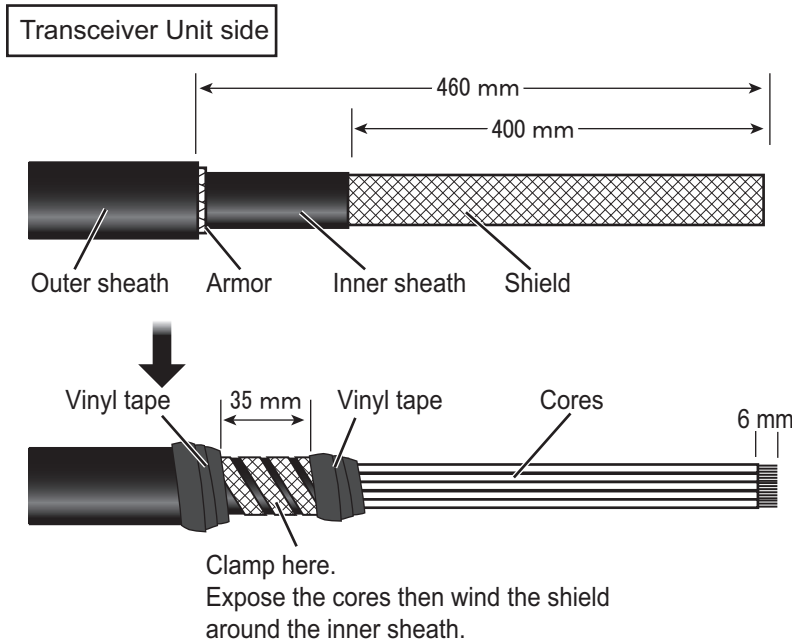
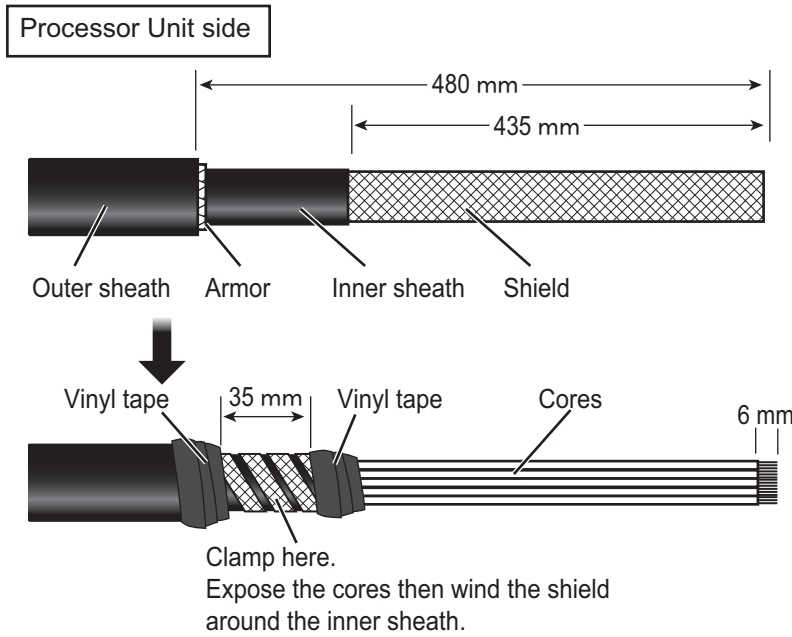

How to connect wires to a terminal connector

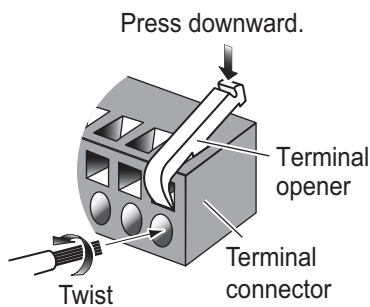

Procedure

1. Twist the cores.
2. Press the terminal opener downward.
3. Insert the wire in the hole.
4. Remove the terminal opener.
5. Pull the wire to confirm that it is secure.

LAN cable

Fabricate the LAN cable (DTIC5E350SLABVCVxxT, max 100 m), referring to the following figure. After fabricating the cable, attach the modular connector.

Note: This equipment only uses straight cables. Use a CAT5E LAN cable.

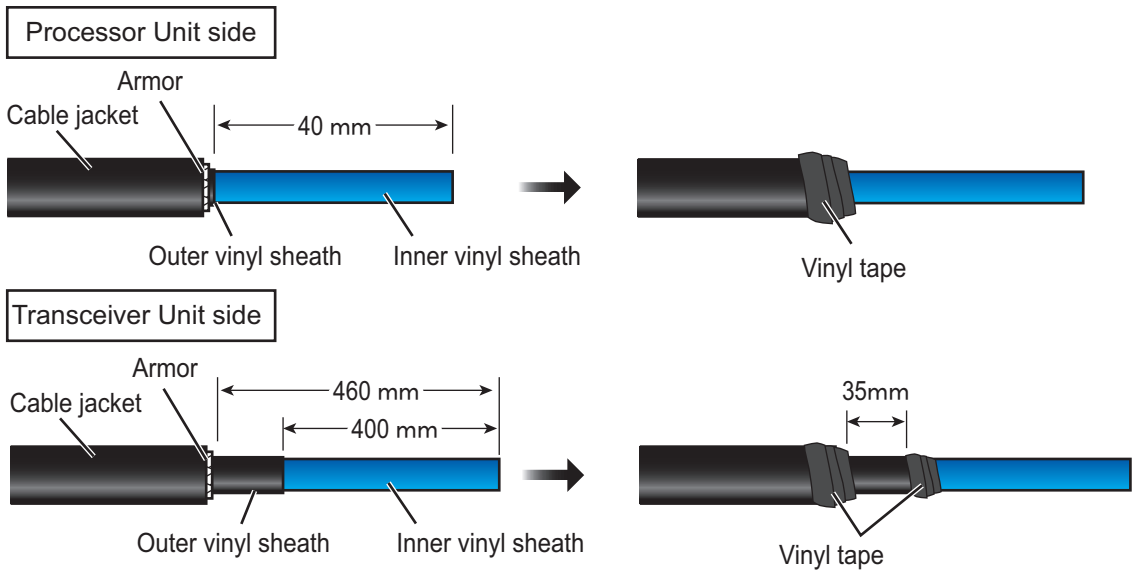

Expose inner vinyl sheath.

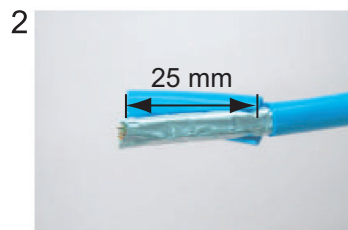

Remove the inner vinyl sheath by approx. 25 mm. Be careful not to damage inner shield and cores.

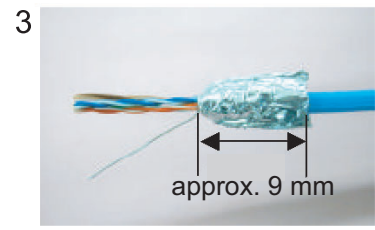

Fold back the shield, wrap it onto the inner vinyl sheath and cut it, leaving approx. 9 mm.

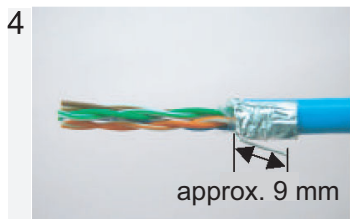

Fold back drain wire and cut it, leaving approx. 9 mm.

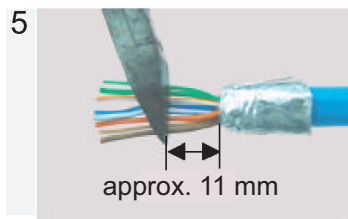

Straighten and flatten the cores in colored order and cut them, leaving approx. 11 mm.

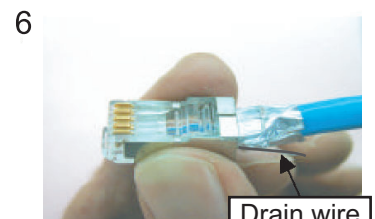

Insert the cable into the modular plug so that the folded part of the shield enters into the plug housing. The drain wire should be located on the tab side of the jack.



Using special crimping tool MPT5-8AS (PANDUIT CORP.), crimp the modular plug. Finally, check the plug visually.

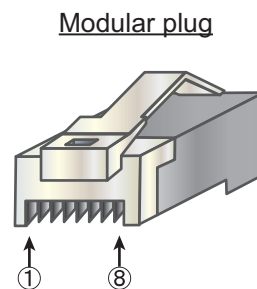

[Straight cable]

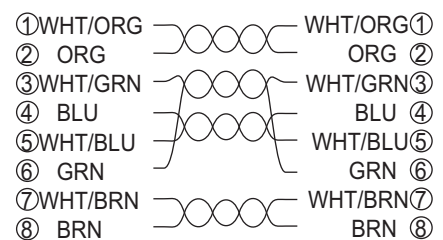

TTYCSLA cable

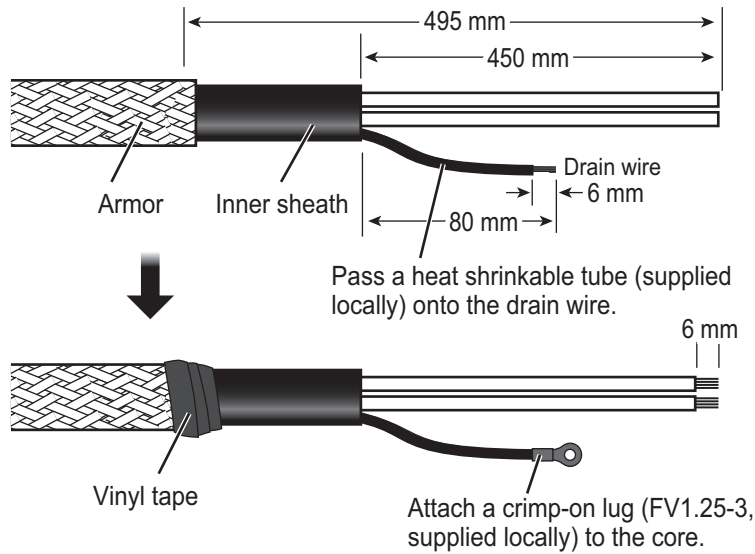

How to connect wires to a terminal connector

Press downward.
Terminal opener
Terminal connector
Twist

Procedure

1. Twist the cores.
2. Press the terminal opener downward.
3. Insert the wire in the hole.
4. Remove the terminal opener.
5. Pull the wire to confirm that it is secure.

2.1.4 How to change the fuse

Change the fuse in the fuse holder on the power cable according to the input voltage, referring to the following table. Fuses are supplied as spare parts.

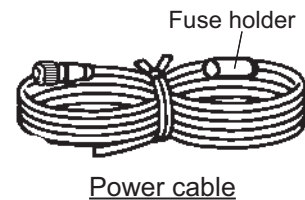

⚠ WARNING

⚠ Use the proper fuse.

Fuse rating is shown in the table below. Use of a wrong fuse can result in damage to the equipment.

Input voltage	Rating of fuse
12 VDC	15 A (factory default)
24 VDC	7 A

2.1.5 External switch connection

External switches can be connected to the TB1 terminal in the processor unit to provide one-touch access to a desired menu item or menu. Up to four external switches, each with an individual function, can be connected.

Use a push button switch (momentary contact) for the external switch. For how to assign the function to the external switch, see the operator’s manual.

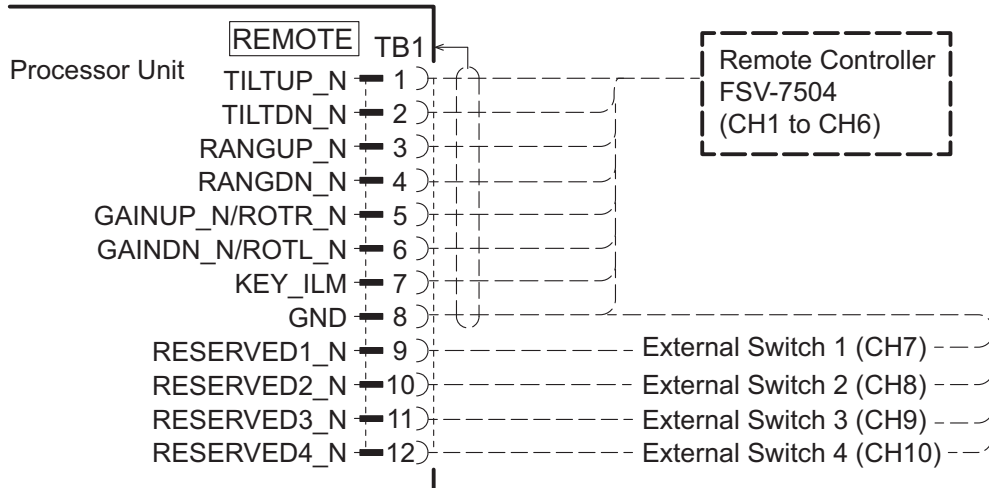

2.1.6 External KP connection

Note: To use the 3D functions, output the KP signal from the transceiver unit to external equipment. If the KP (Keying Pulse) signal is synchronized from external equipment, the 3D function may not work properly.

KP input

To synchronize the KP (Keying Pulse) signal from external equipment, make the connection as follows:

- When the external equipment is a current drive circuit: Use the TB8-1 and TB8-2.
- When the external equipment is a voltage drive circuit: Use the TB8-3 and TB8-4.

The signals for current and voltage drive circuit cannot be used simultaneously.

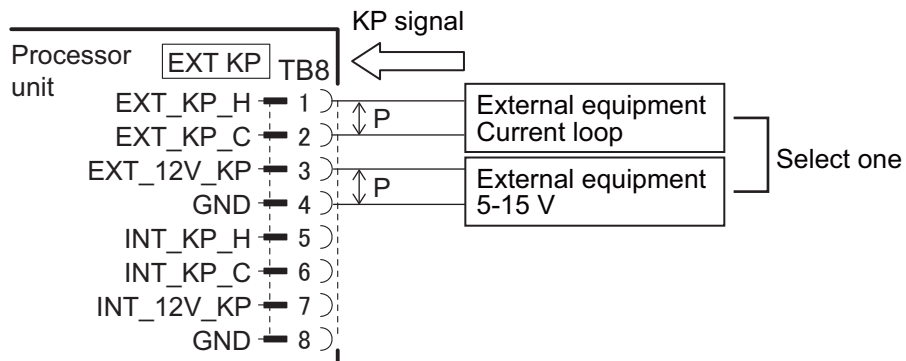

KP output

To output the KP signal from the transceiver unit to external equipment, make the connection as follows:

- When the external equipment is a current drive circuit: Use the TB8-5 and TB8-6.
- When the external equipment is a voltage drive circuit: Use the TB8-7 and TB8-8.

The signals for current and voltage drive circuit can be used simultaneously, for separate destinations.

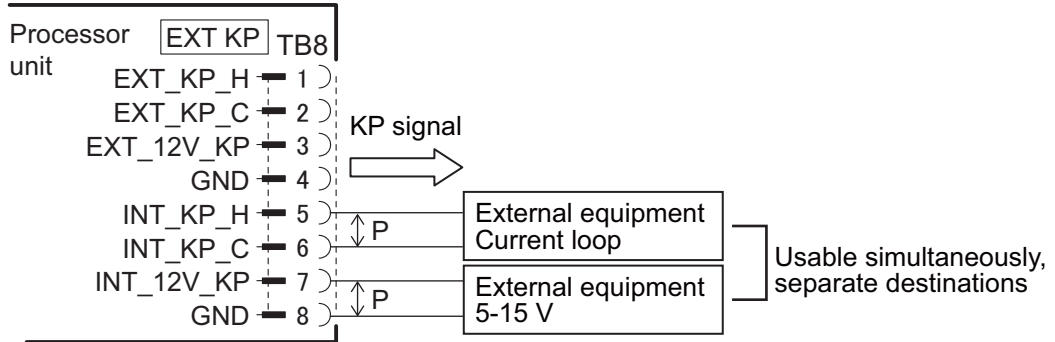

2.2 Control Unit

Connect the control unit to the J1 or J2 terminal in the processor unit.

Ground the control unit, using a ground wire (IV-1.25sq., supplied locally).

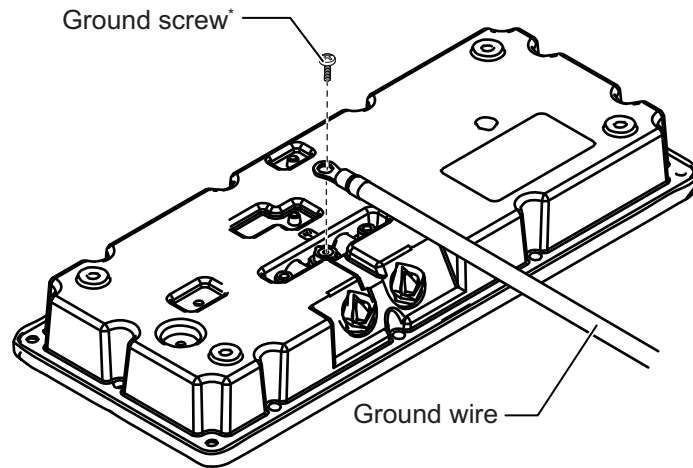

*: Pre-attached to the unit.

2.3 Transceiver Unit

2.3.1 Internal wiring and cable clamp position

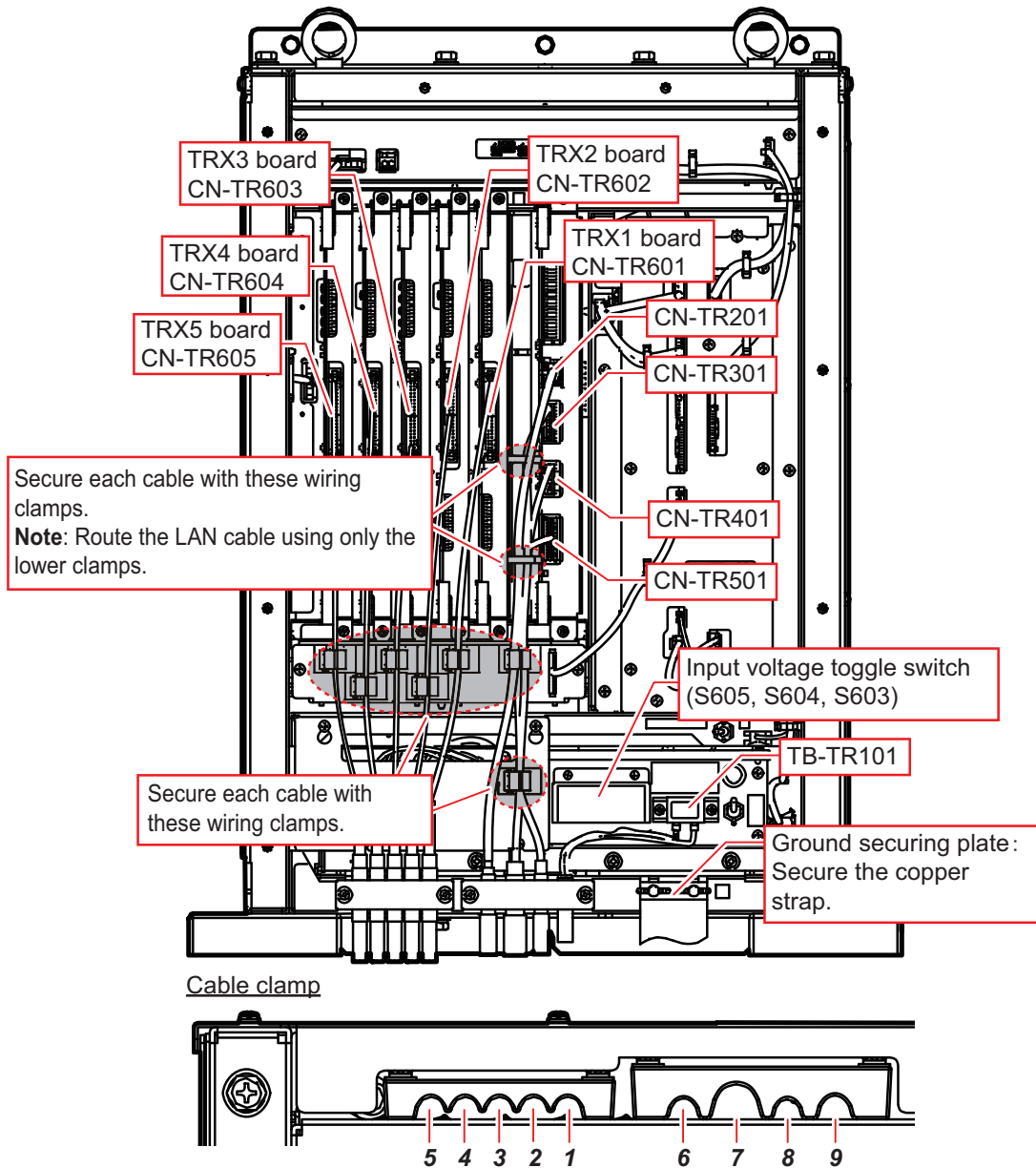

Clamp position	Connect to	Cable from	Cable
1	CN-TR601	Matching box	10CA10110
2	CN-TR602		
3	CN-TR603		
4	CN-TR604		
5	CN-TR605		
6	CN-TR201	Processor unit	DTIC5E350SLABVCVxxT*
7	CN-TR401	Control box	10CA10147
	CN-TR501		
8	CN-TR301	Processor unit	10S2380*
9	TB-TR101	100/110/115/230/230 VAC	DPYCY-2.5*

*: Fabricate the cables referring to section 2.3.2.

Cable from matching box (10CA10110 cable)

The labels on each 10CA10110 cable from the matching box indicate where to connect the cable. For example, the cable labeled "TRANSCIEVER UNIT 2" is connected to the TRX2 board (CN-TR602).

The number on the label must match the number of the TRX board.



Notice before turning the power on

Before turning the power on, switch the input voltage toggles (S603, S604, S605) according to the input voltage. This prevents the incorrect voltage being input to the transceiver unit. For details about the input voltage toggle switch, see section 2.3.3.

2.3.2 Cable fabrication

10S2380 cable

Fabricate the cable referring to section 2.1.3.

LAN cable

Fabricate the cable referring to section 2.1.3.

DPYCY-2.5 cable

Fabricate the cable as shown in the following figure.

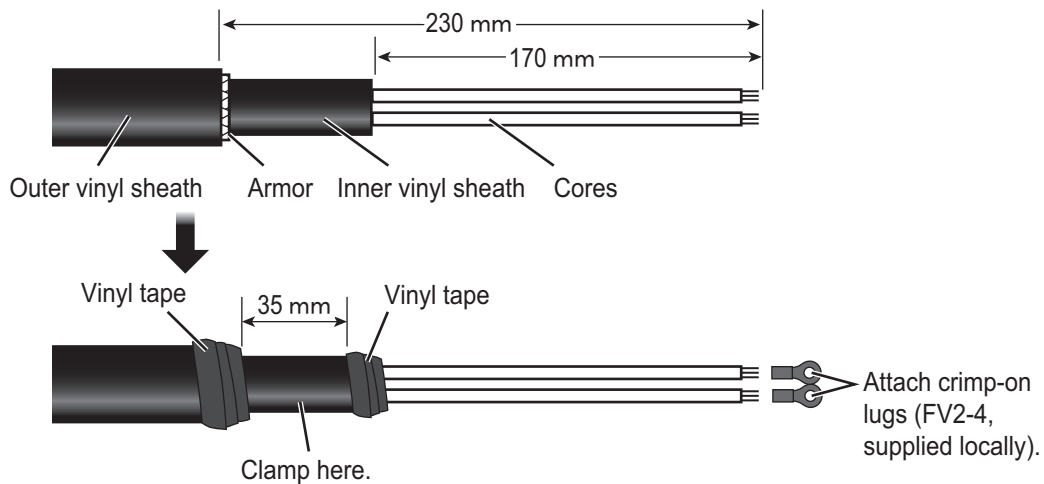

2.3.3 Input voltage

The transceiver unit is shipped from the factory with the input voltage set for 230 VAC. If your vessel uses a different voltage, change the toggle switches referring to the following table.

Input voltage	S605	S604	S603
100V	L	L	L
110V	L	L	H
115V	L	H	H
220V	H	L	H
230V (default)	H	H	H

2.3.4 Removing and inserting a printed circuit board

To remove a printed circuit board in the transceiver unit, unfasten the securing screw and unlock the lock lever.

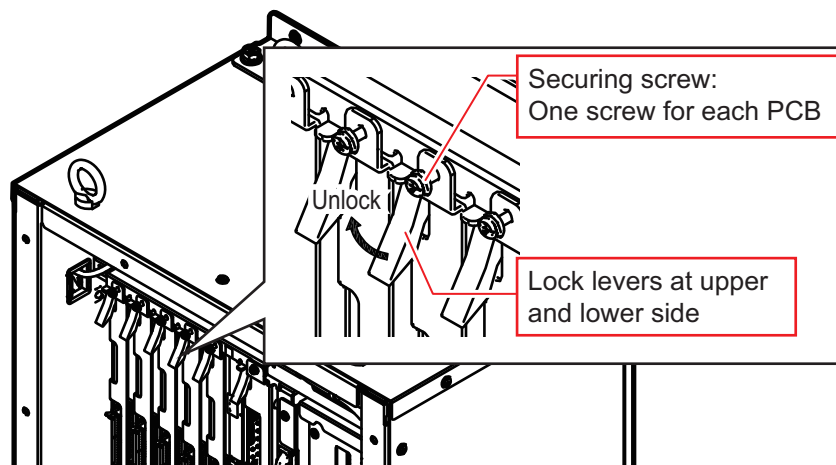

To insert a printed circuit board, insert the board until the lock lever catches on the upper and lower projection, then push the lock lever inwards (see the following figure).

After the board is locked in place with the lock lever, confirm that the inside end of the securing screw is firmly against the chassis, then fasten the securing screw. If the screw is not firmly against the chassis, the board may be inserted incorrectly. Remove and re-insert the board.

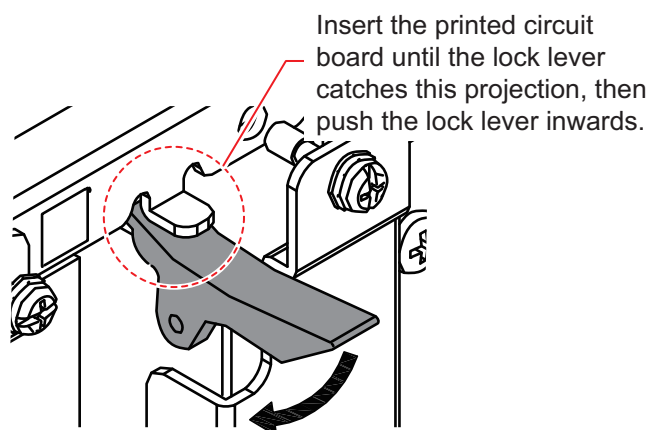

2.4 Control Box

Note 1: To prevent accidents and injury while conducting maintenance or wiring, turn the control box off at the breaker.

Note 2: If the wiring for the motor and brake is incorrect, the transducer may be lowered unintentionally. Check the interconnection diagram at the back of this manual or wiring label on the rear side of the control box cover to confirm that the internal wiring is correct before turning the power on.

2.4.1 Internal wiring and cable clamp position

The connection LED lights up in red color to indicate that the wiring is correct. Confirm that the LED is lit. If the LED is not lit, disconnect the power cables and reconnect them correctly. Re-apply the power and confirm that the LED is lit.

The hull unit does not work if the connections are incorrect.

- Power connected correctly: LED lights in red.
- Incorrect connection: LED does not light.

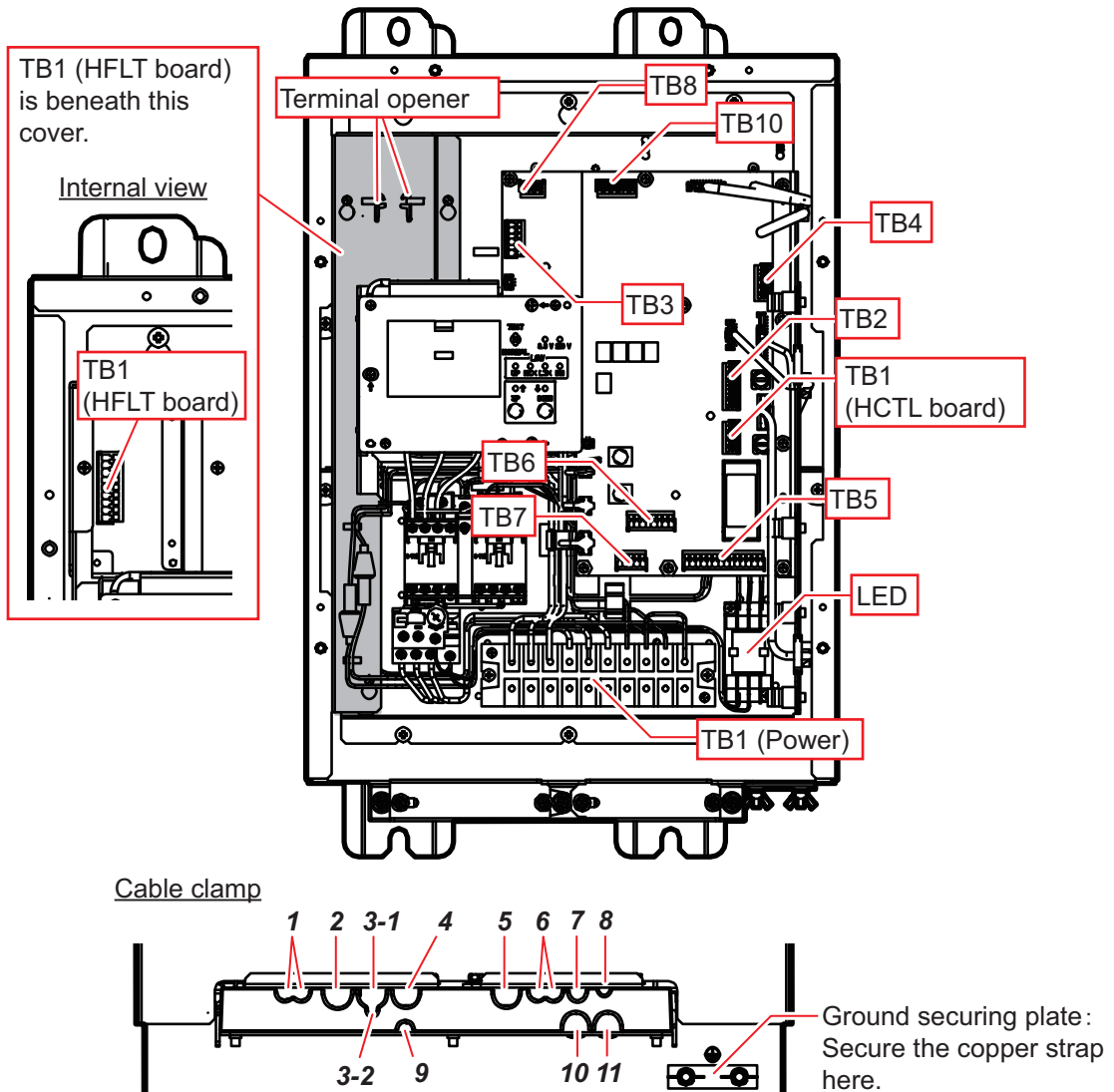

Clamp position	Cable	Color code*3	Connect to	Cable from
When the control box is mounted to the hull unit				
1	10CA10133	Blue	TB1 (HFLT)	Rotation motor
	10CA10134	Red		Pitch motor
2	TPYCY-4*1	-	TB1 (Power)	Ship's supply
3-1	Limit Switch	-	TB5	Sensor
	Emergency Stop Button	-	TB7	
	Ratchet Wrench	-	TB7	
3-2	Encoder	-	TB6	
4	2PCNT 5X2SQ	-	TB1 (Power)	Motor
5	10CA10147*2	-	TB1 (HCTL)/TB2	Transceiver unit
6	10CA10135	Yellow/Blue	TB8	Rotation resolver
	10CA10136	Yellow/Red	TB10	Pitch resolver
7	10CA10141	Yellow	TB4	Motion sensor
8	Signal light	-	TB3	Signal light (supplied locally)
9	Not used	-	-	-
10	Not used	-	-	-
11	Not used	-	-	-
When mounting the control box separately from the hull unit				
1	10CA10137*2	Blue	TB1 (HFLT)	Rotation motor
	10CA10138*2	Red		Pitch motor
2	TPYCY-4*1	-	TB1 (Power)	Ship's power supply
3	10CA10127*1	-	TB5/TB6	Sensor
4	FA-TPYCY-4*1	-	TB1 (Power)	Motor
5	10CA10147*2	-	TB1 (HCTL)/TB2	Transceiver unit
6	10CA10139*2	Yellow/Blue	TB8	Rotation resolver
	10CA10140*2	Yellow/Red	TB10	Pitch resolver
7	Not used	Yellow	-	Motion sensor
8	Not used	-	-	-
9	PNCTF-S 4CX0.75*1	-	TB1 (Power)	Brake
10	Not used	-	-	-
11	10CA10128*1	-	TB3/TB4/TB7	Sensor

*1: Fabricate the cables referring to section 2.4.2.

*2: Attach terminal connectors referring to section 2.4.3.

*3: Color code indicates the color of the cable tie attached to the cable end. This color is used to identify the cables.

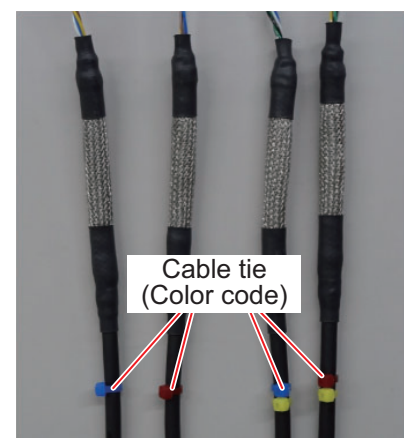

2.4.2 Cable fabrication

TPYCY-4 cable (power cable)

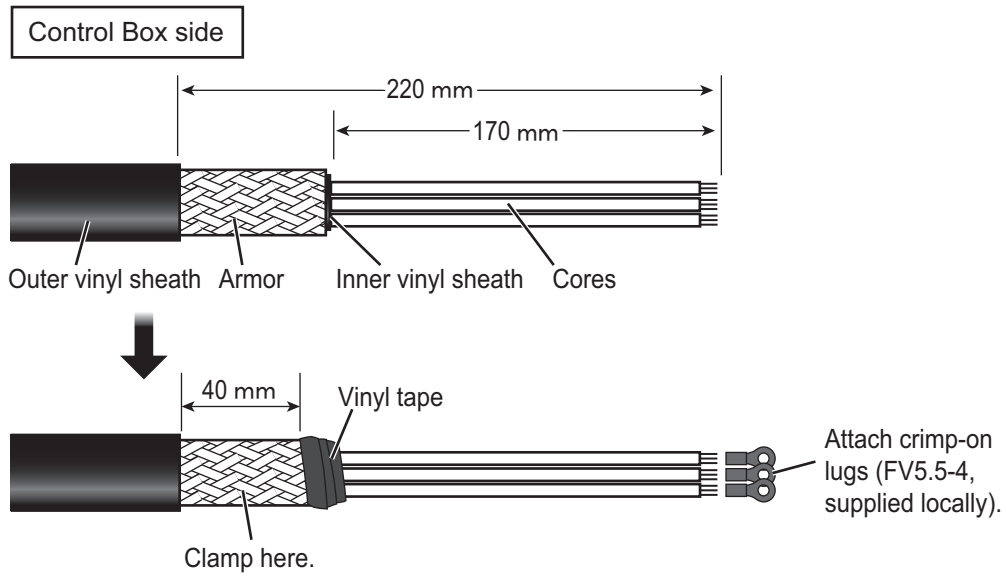

FA-TPYCY-4 cable (between the control box and extension box)

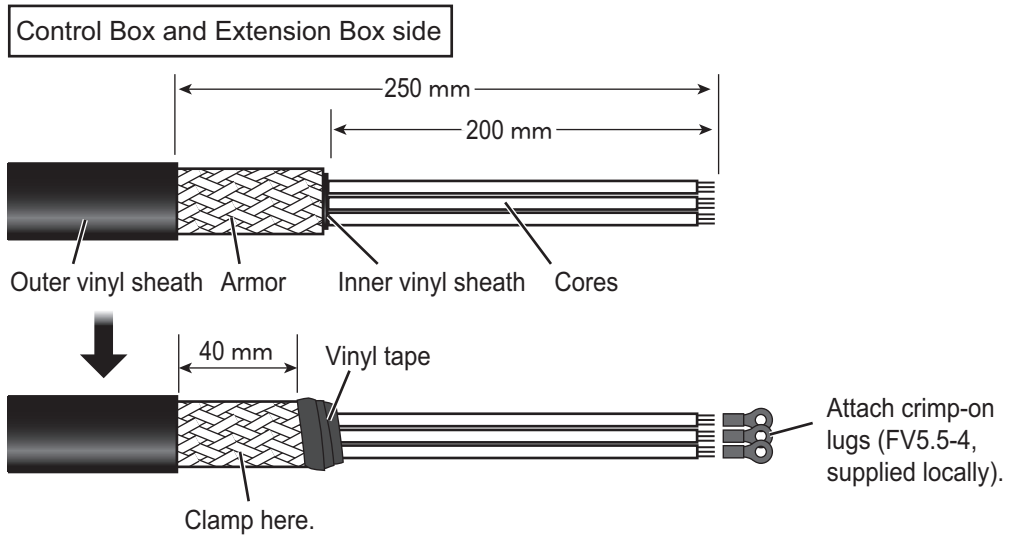

10CA10127 cable

Fabricate the COSPEVVSBC 12PX0.2LF (10S10166) cable as follows to make the 10CA10127 cable.

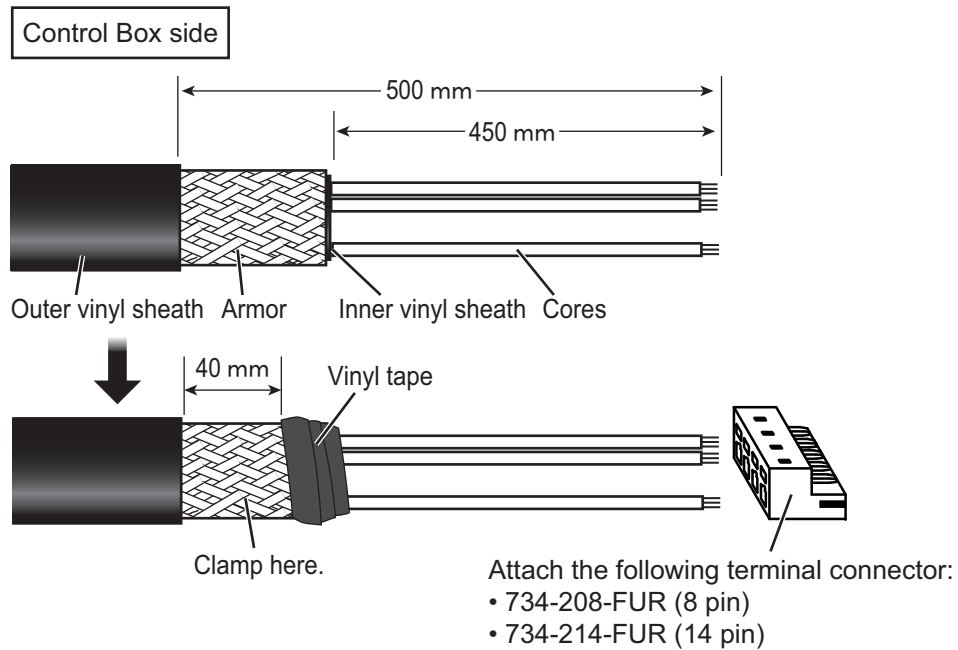

Pair No.	Core color 1 ^{*1}	Connect to	Core color 2 ^{*1}	Connect to
1	White	TB5-1	Blue	TB5-2
2	White	TB5-3	Green	TB5-4
3	White	TB5-5	Yellow	TB5-6
4	White	TB5-7	Brown	TB5-8
5	Black	TB5-9	Blue	TB5-10
6	Black	TB5-11	Green	TB5-12
7	Black	TB5-13	Yellow	TB5-14
8	Black	TB6-2 ^{*2}	Brown	TB6-2 ^{*2}
9	Red	TB6-1 ^{*2}	Blue	TB6-1 ^{*2}
10	Red	TB6-3	Green	TB6-4
11	Red	TB6-5	Yellow	TB6-6
12	Red	TB6-7	Brown	TB6-8

^{*1}: Core color 1 and core color 2 indicate the wire from a twisted pair to be used.

^{*2}: TB6-1 and TB6-2 use two wires for each pin.

2. WIRING

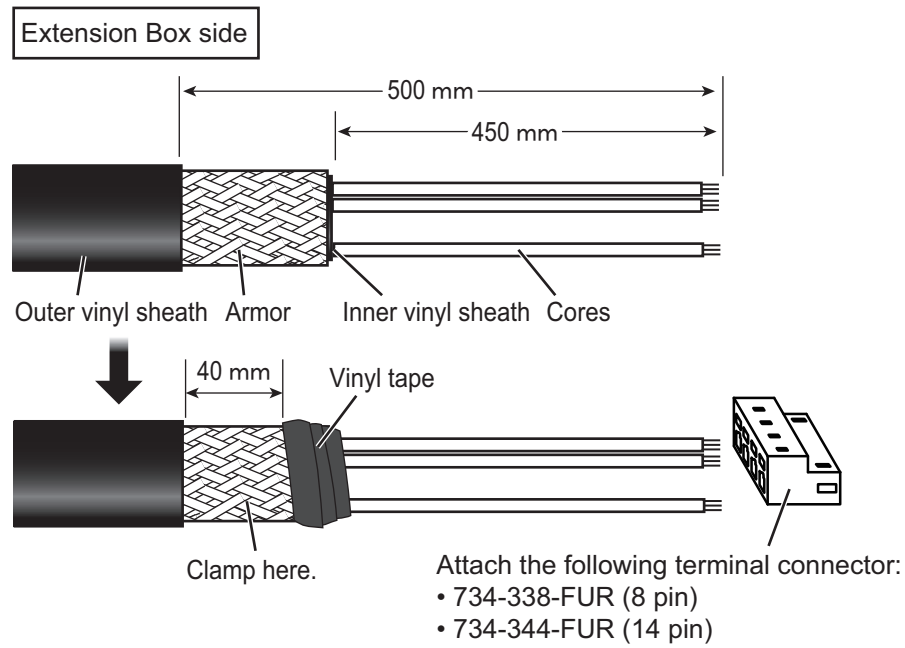

Pair No.	Core color 1* ¹	Connect to	Core color 2* ¹	Connect to
1	White	J2-1	Blue	J2-2
2	White	J2-3	Green	J2-4
3	White	J2-5	Yellow	J2-6
4	White	J2-7	Brown	J2-8
5	Black	J2-9	Blue	J210
6	Black	J2-11	Green	J2-12
7	Black	J2-13	Yellow	J2-14
8	Black	J1-2* ²	Brown	J1-2* ²
9	Red	J1-1* ²	Blue	J1-1* ²
10	Red	J1-3	Green	J1-4
11	Red	J1-5	Yellow	J1-6
12	Red	J1-7	Brown	J1-8

*¹: Core color 1 and core color 2 indicate the wire from a twisted pair to be used.

*²: J1-1 and J1-2 use two wires for each pin.

10CA10128 cable

Fabricate the COSPEVVSBC 12PX0.2LF (10S10166) cable as follows to make the 10CA10128 cable.

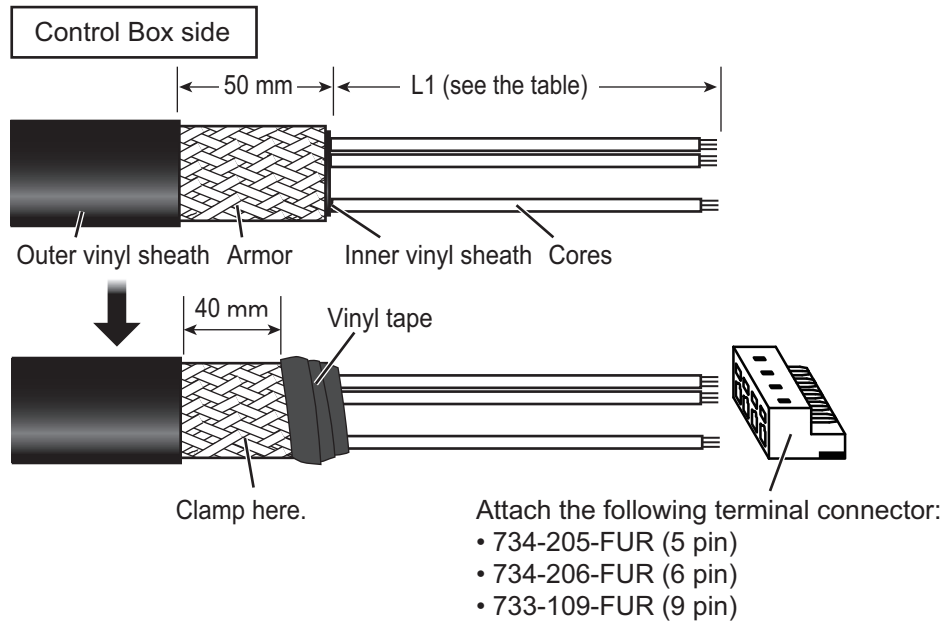

Pair No.	Core color 1*	L1	Connect to	Core color 2*	L1	Connect to
1	White	500 mm	TB4-5	Blue	500 mm	TB4-7
2	White	500 mm	TB4-6	Green	500 mm	TB4-8
3	White	500 mm	TB4-1	Yellow	500 mm	TB4-2
4	White	0 mm	-	Brown	500 mm	TB4-3
5	Black	0 mm	-	Blue	0 mm	-
6	Black	700 mm	TB3-6	Green	700 mm	TB3-5
7	Black	700 mm	TB3-1	Yellow	700 mm	TB3-2
8	Black	700 mm	TB3-3	Brown	700 mm	TB3-4
9	Red	0 mm	-	Blue	0 mm	-
10	Red	0 mm	-	Green	0 mm	-
11	Red	400 mm	TB7-1	Yellow	400 mm	TB7-2
12	Red	400 mm	TB7-4	Brown	400 mm	TB7-5

*: Core color 1 and core color 2 indicate the wire from a twisted pair to be used.

2. WIRING

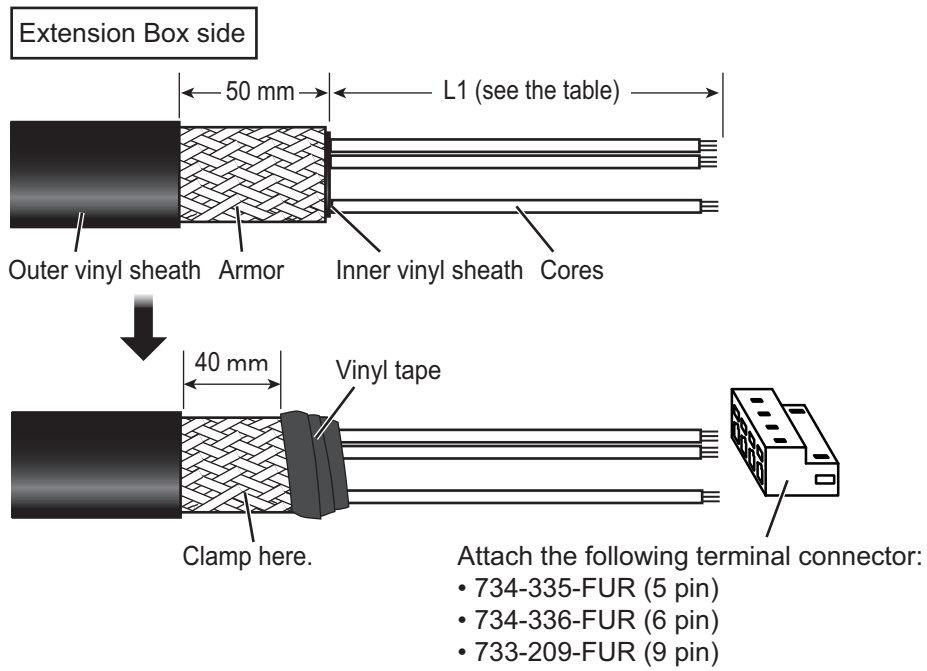

Pair No.	Core color 1*	L1	Connect to	Core color 2*	L1	Connect to
1	White	450 mm	J4-5	Blue	450 mm	J4-7
2	White	450 mm	J4-6	Green	450 mm	J4-8
3	White	450 mm	J4-1	Yellow	450 mm	J4-2
4	White	0 mm	-	Brown	450 mm	J4-3
5	Black	0 mm	-	Blue	0 mm	-
6	Black	450 mm	J5-6	Green	450 mm	J5-5
7	Black	450 mm	J5-1	Yellow	450 mm	J5-2
8	Black	450 mm	J5-3	Brown	450 mm	J5-4
9	Red	0 mm	-	Blue	0 mm	-
10	Red	0 mm	-	Green	0 mm	-
11	Red	450 mm	J3-1	Yellow	450 mm	J3-2
12	Red	450 mm	J3-4	Brown	450 mm	J3-5

*: Core color 1 and core color 2 indicate the wire from a twisted pair to be used.

PNCTF-S 4CX0.75 cable

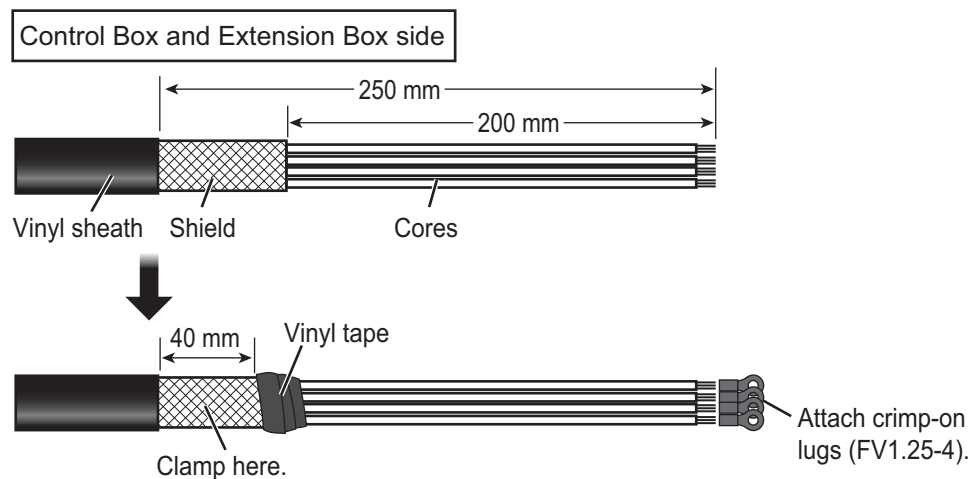

2.4.3 Attaching the terminal connector

Attach the terminal connector to the cable end, referring to the following figure.

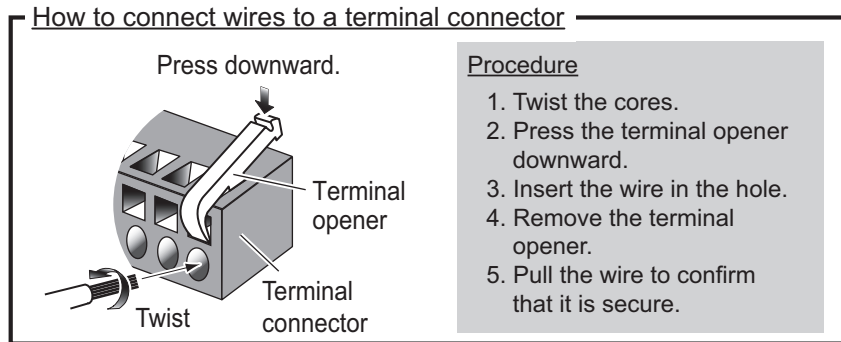

The following table shows the terminal connector for each cable.

Cable	Control box side		Extension box side	
	Terminal connector	Connect to	Terminal connector	Connect to
10CA10127	734-214-FUR (14 pin)	TB5	734-344-FUR (14 pin)	J2
	734-208-FUR (8 pin)	TB6	734-338-FUR (8 pin)	J1
10CA10128	734-206-FUR (6 pin)	TB3	734-336-FUR (6 pin)	J5
	733-109-FUR (9 pin)	TB4	733-209-FUR (9 pin)	J4
	734-205-FUR (5 pin)	TB7	734-335-FUR (5 pin)	J3
10CA10137 10CA10138	734-209-FUR (9 pin)	TB1 (HFLT board)	734-339-FUR (9 pin)	J9
10CA10139	733-106-FUR (6 pin)	TB8	733-206-FUR (6 pin)	J6
10CA10140	733-110-FUR (10 pin)	TB10	733-210-FUR (10 pin)	J8
10CA10147	733-108-FUR (8 pin)	TB1 (HCTL board)	-	-
	733-112-FUR (12 pin)	TB2	-	-

Note: The terminal opener and wire length used are different for each terminal connector. See the following table.

Terminal Connector	Terminal opener	Recommended wire length to be exposed
White terminal connector (733 series)	Yellow terminal opener	5 to 6 mm
Orange terminal connector (734 series)	White terminal opener	7 mm

2.4.4 How to connect the signal light

Connect a signal light (supplied locally) to TB3 in the control box. Contact specifications of this equipment are as follows. Select an appropriate signal light.

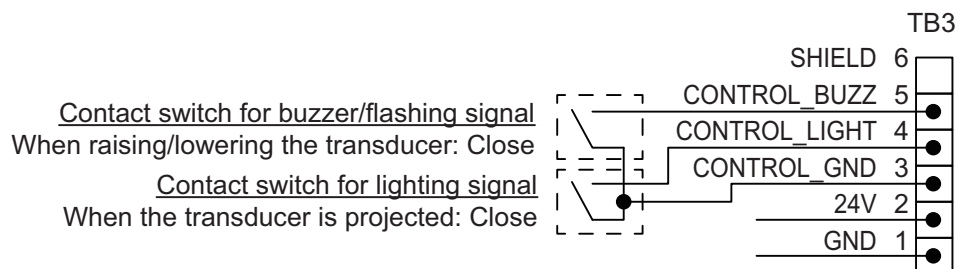

2. WIRING

Pin No.	Signal	Description	Remarks
1	GND	GND	-
2	24V	Power output (24 VDC)	24 VDC, steady state current 1.0 A or less
3	CONTROL_GND	GND for TB3-4 and TB3-5	-
4	CONTROL_LIGHT	Contact output for lighting signal	60 VDC, 0.5 A or less
5	CONTROL_BUZZ	Contact output for buzzer/flashing signal	60 VDC, 0.5 A or less
6	SHIELD	Open	-

The following example uses the recommended signal light (PEW-24AB, manufacturer: PATLITE).

Note: For signal lights other than the recommended product, refer to the signal light's wiring diagram before connecting the light to the FSV-75.

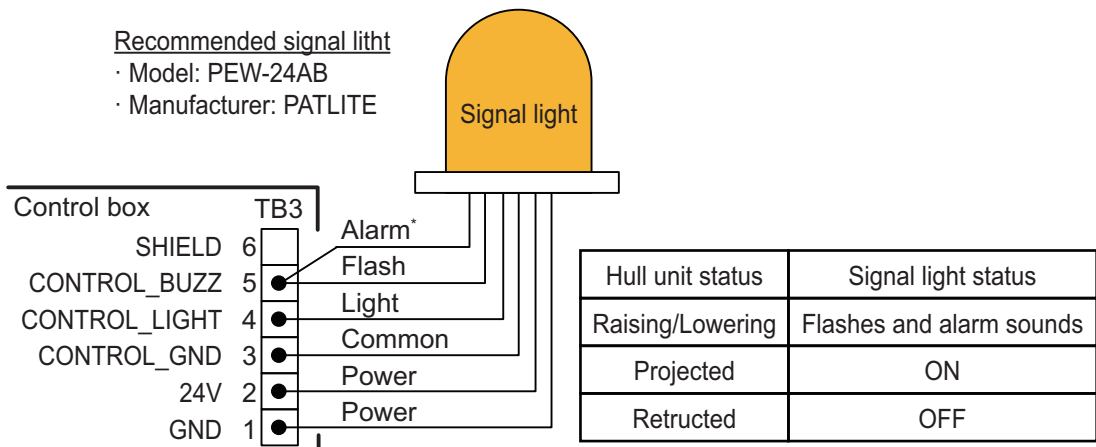

*: If the alarm sound is not required when lowering/raising the transducer, set the alarm signal as open.

2.4.5 Contact output

TB5-1 and TB5-2 in the control box can output a contact signal. Contact specifications of this equipment are as follows:

Contact specifications

- When the transducer is retracted: Open
- Others: Closed

Contact rating

- 125 VAC, 3 A or less
- 30 VDC, 1.5 A or less

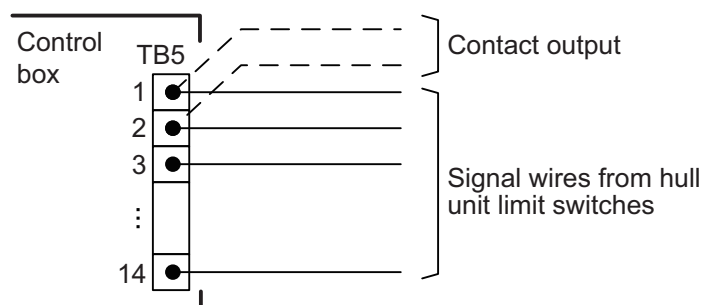

Note: To use the contact signal from TB5, twist the contact output wires with the hull unit limit switch wires, then connect the wires to TB5-1 and TB5-2.

2.5 Matching Box

Connect the transducer cable (10CA10144) and transceiver unit cable (10CA10110, ×5) to the connectors in the matching box.

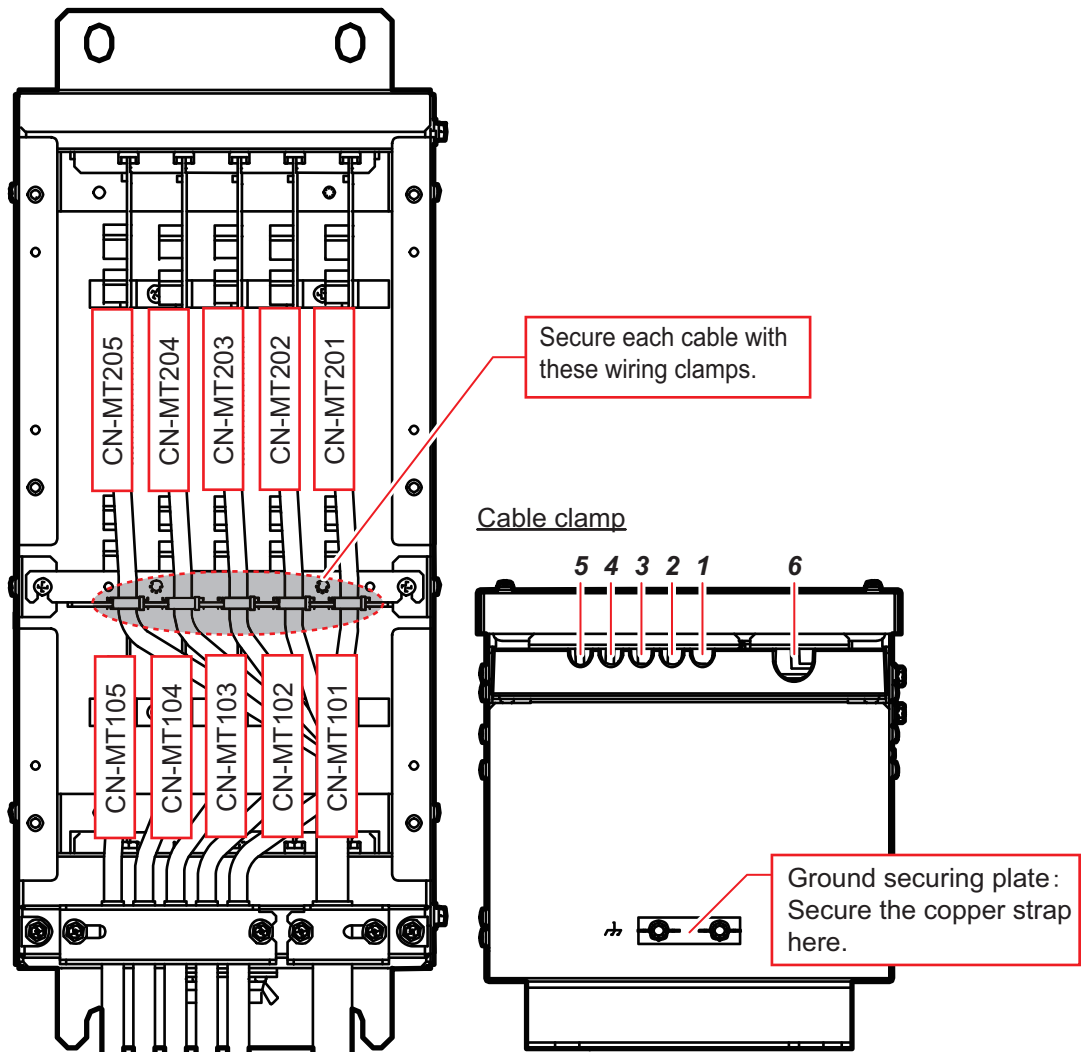

Clamp position	Cable	Connect to	Cable from
1	10CA10110 (No.1)	CN-MT101	Transceiver unit
2	10CA10110 (No.2)	CN-MT102	
3	10CA10110 (No.3)	CN-MT103	
4	10CA10110 (No.4)	CN-MT104	
5	10CA10110 (No.5)	CN-MT105	
6	10CA10144	CN-MT201 CN-MT202 CN-MT203 CN-MT204 CN-MT205	Transducer

A label is attached to each cable end, indicating the connector number to be used. Connect each cable according to its label.

2. WIRING

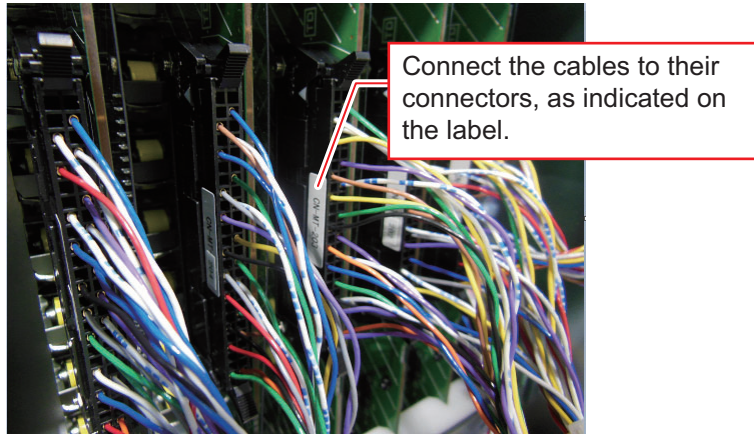

2.6 Extension Box

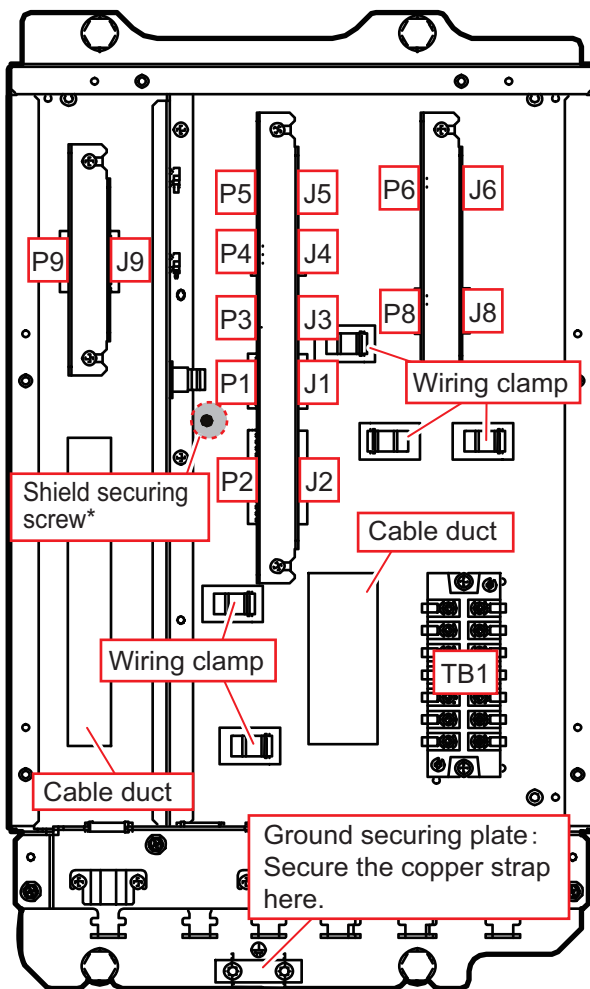

After connecting the terminal connectors, place the connectors in position, then attach the securing plate to secure the connectors.

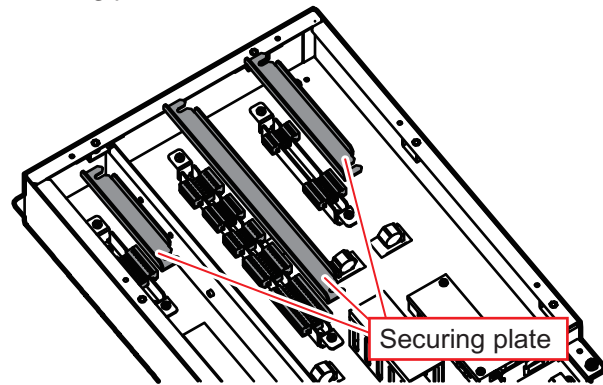

After wiring, pass each cable through the cable duct and wiring clamp.

Cable clamp

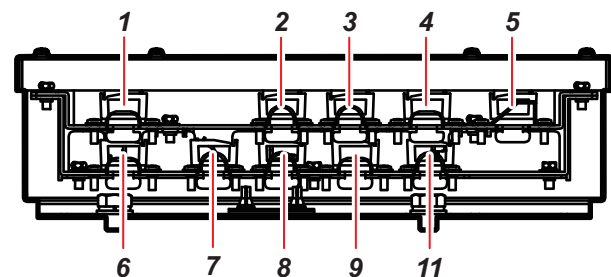

*: Fasten the shield of the cable that is connected to P1.

Clamp position	Cable	Connect to	Cable from
1	10CA10133	P9 (9 pin)	Control box
	10CA10134	P9 (9 pin)	
2	10CA10127* ¹	J1 (8 pin)	
		J2 (14 pin)	
3	10CA10128* ¹	J3 (5 pin)	
		J4 (9 pin)	
		J5 (6 pin)	
4	10CA10139* ²	J6 (6 pin)	
5	10CA10140* ²	J8 (10 pin)	
	FA-TPYCY-4* ¹	TB1	
	PNCTF-S 4CX0.75* ¹	TB1	
6	10CA10137* ²	J9 (9 pin)	Rotation motor
	10CA10138* ²	J9 (9 pin)	Pitch motor
7	Emergency stop button	P3 (5 pin)	Sensor
	Ratchet wrench	P3 (5 pin)	
	Signal light	P5 (6 pin)	
	10CA10141	P4 (9 pin)	
8	Limit switch	P2 (14 pin)	Sensor
	Rotary encoder	P1 (8 pin)	
9	10CA10135	P6 (6 pin)	Rotation resolver
	10CA10136	P8 (10 pin)	Pitch resolver
10	2PCNT 5X2SQ	TB1	Raise/lower motor

*¹: Fabricate the cables referring to section 2.4.2.

*²: Attach terminal connectors referring to section 2.4.3.

2.7 Input/Output Sentences (NMEA0183)

This equipment can input/output the following sentences:

Sentence	Data	NMEA0183 Version
Input sentences		
CUR	Water Current Layer	Ver.1.5/2.0/3.0/4.0/4.1
DBS	Depth Below Surface	Ver.1.5/2.0/3.0/4.0/4.1
DBT	Depth Below Transducer	Ver.1.5/2.0/3.0/4.0/4.1
DPT	Depth	Ver.1.5/2.0/3.0/4.0/4.1
GGA	Global Positioning System Fix Data	Ver.1.5/2.0/3.0/4.0/4.1
GLL	Geographic Position	Ver.1.5/2.0/3.0/4.0/4.1
GNS	GNSS Fix Data	Ver.1.5/2.0/3.0/4.0/4.1
HDG	Heading, Deviation & Variation	Ver.1.5/2.0/3.0/4.0/4.1
HDM	Heading, Magnetic	Ver.1.5/2.0/3.0/4.0/4.1
HDT	Heading True	Ver.1.5/2.0/3.0/4.0/4.1
MDA	Meteorological Composite	Ver.1.5/2.0/3.0/4.0/4.1
MTW	Water Temperature	Ver.1.5/2.0/3.0/4.0/4.1
MWV	Wind Speed and Angle	Ver.1.5/2.0/3.0/4.0/4.1
RMC	Recommended minimum Specific GNSS Data	Ver.1.5/2.0/3.0/4.0/4.1
THS	True Heading and Status	Ver.1.5/2.0/3.0/4.0/4.1

2. WIRING

Sentence	Data	NMEA0183 Version
VBW	Dual Ground/Water Speed	Ver. 1.5/2.0/3.0/4.0/4.1
VDR	Set & Drift	Ver. 1.5/2.0/3.0/4.0/4.1
VHW	Water Speed and Heading	Ver. 1.5/2.0/3.0/4.0/4.1
VTG	Pitch and Roll	Ver. 1.5/2.0/3.0/4.0/4.1
VWR	Relative (Apparent) Wind Speed and Angle	Ver. 1.5/2.0/3.0/4.0/4.1
VWT	True Wind Speed Angle	Ver. 1.5/2.0/3.0/4.0/4.1
ZDA	Time and Date	Ver. 1.5/2.0/3.0/4.0/4.1
Output sentences		
TLL	Target Latitude and Longitude	Ver. 1.5/2.0/3.0/4.0/4.1
evt	FURUNO proprietary sentence	-
fkv	FURUNO proprietary sentence	-
fmg	FURUNO proprietary sentence	-
fvf	FURUNO proprietary sentence	-
pidat	FURUNO proprietary sentence	-
sht	FURUNO proprietary sentence	-
tfm	FURUNO proprietary sentence	-
tlm	FURUNO proprietary sentence	-
tqm	FURUNO proprietary sentence	-

3. ADJUSTMENTS

3.1 DIP Switch Settings in the Processor Unit

When a monitor is connected via a video distributor or matrix switcher, the resolution may not display correctly. If this occurs, change the DIP switch settings for SW4/SW5 on the PCRI board. The changed settings fix the output to SXGA.

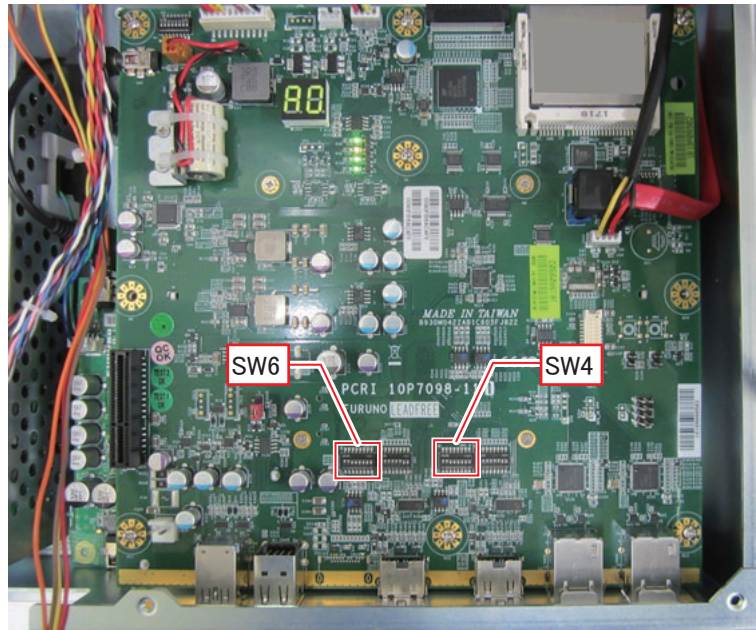

Note: Only use the settings outlined in the following table.

1	2	3	4	5	6	7	8	Remarks
DIP switch SW4 is used for setting the output resolution from HDMI1.								
ON	ON	OFF	OFF	OFF	OFF	OFF	OFF	HDMI1 port outputs at the maximum resolution of the monitor connected to the processor unit (factory default).
OFF	OFF	ON	ON	OFF	OFF	OFF	OFF	HDMI1 port outputs SXGA.
DIP switch SW6 is used for setting the output resolution from HDMI2.								
ON	ON	OFF	OFF	OFF	OFF	OFF	OFF	HDMI2 port outputs at the maximum resolution of the monitor connected to the processor unit (factory default).
OFF	OFF	ON	ON	OFF	OFF	OFF	OFF	HDMI2 port outputs SXGA.

3.2 How to Change the Displayed Language

The language in which the menus and indications are displayed can be changed. This unit is shipped with the language set to English.

1. Press the **MENU/ESC** key to open the menu.

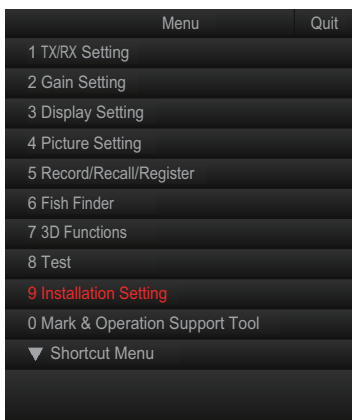

2. Select [9 Installation Setting].
The following confirmation message appears.

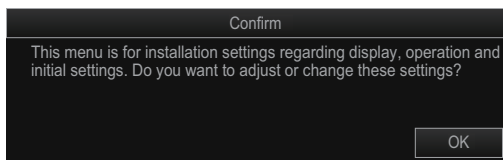

3. Select [OK].

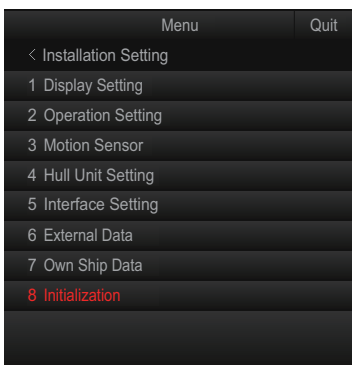

4. Select [8 Initialization].
The following confirmation message appears.

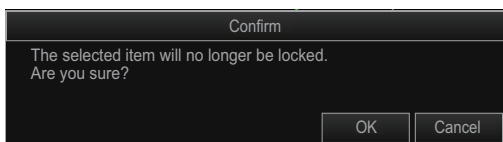

5. Select [OK].

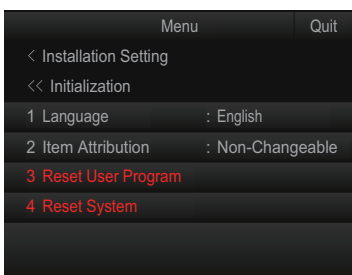

6. Select [1 Language].
7. Select the appropriate language.
8. Select [Quit].
9. Press and hold the **MENU/ESC** key to close the menu.

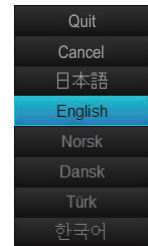

3.3 How to Register the Transducer Position

To display the distance which the transducer is protruded, the limit switch location must be entered at the processor unit.

This setting requires the transducer to be protruded from a fully retracted position. Make sure there is sufficient room for full protrusion.

1. Press the **MENU/ESC** key to open the menu.

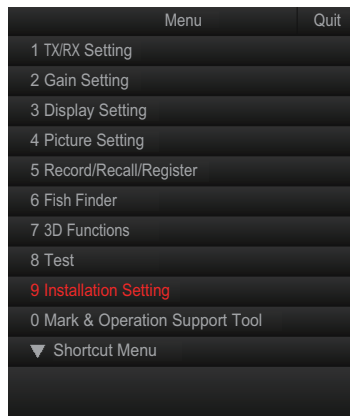

2. Select [9 Installation Setting].
The following confirmation message appears.

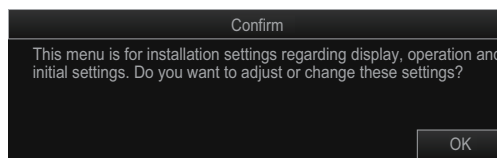

3. Select [OK].

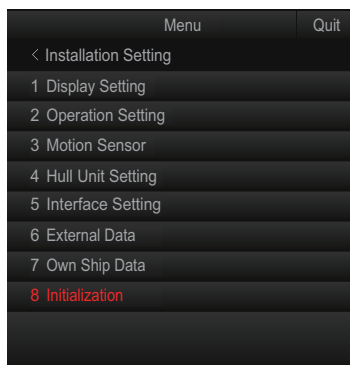

3. ADJUSTMENTS

4. Select [4 Hull Unit Setting].

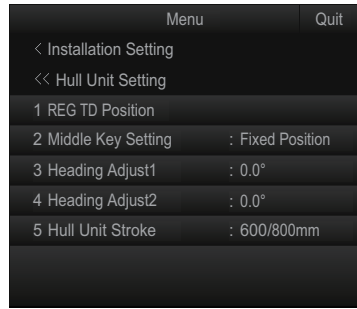

5. Select [1 REG TD Position].
The following confirmation message appears.

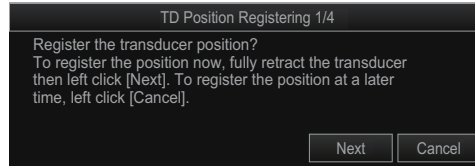

Note: When the transducer position is already registered, the following message appears. To re-register the transducer position, select [Next] the left click.

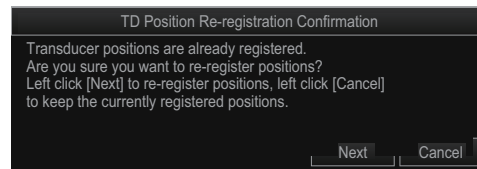

6. Confirm that transducer is retracted, then select [Next].

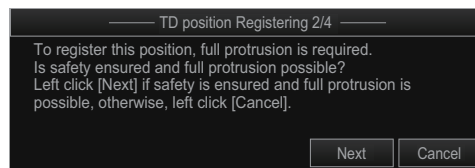

7. Confirm that the transducer can be protruded fully, then select [Next].

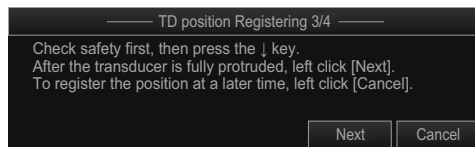

8. Check the safety and press the  (Full-protrude) key to protrude the transducer.
9. When the transducer is at full protrusion, select [Next].

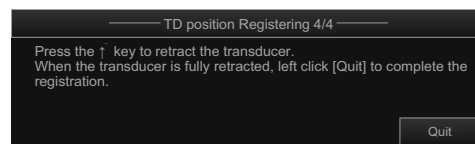

10. Press the  (Retract) key to retract the transducer.
11. Select [Quit].

Note: If transducer registration is aborted for any reason, the following message appears. Select [Quit] to close the message and restart the procedure once safety is ensured.

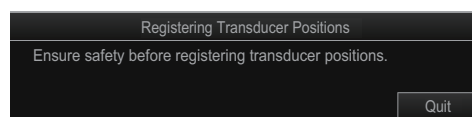

3.4 Hull Unit Checks

Note 1: To avoid damage to the equipment, do not transmit while dry docked.

Note 2: When performing maintenance to the hull unit and checking the movement, make sure that only the hull unit is powered and perform all checks in test mode to avoid accident or injury.

Note 3: Make sure all connections to the hull unit are made correctly, referring to the wiring table attached to the hull unit, to prevent the shaft from being dislodged.

How to check transmit status

Transmission is set to [OFF] as factory default. You can check and change the status by doing the following.

1. Press the **MENU/ESC** key to open the menu.
2. Select [8 Test].

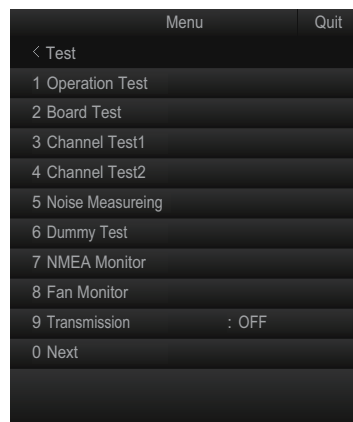

3. Select [9 Transmission].

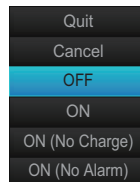

4. Select the appropriate setting.
5. Select [Quit].
6. Press and hold the **MENU/ESC** key to close the menu.

How to check the hull unit

1. Press the power button to turn the power on, then check that the LEDs located to the left of the power button and  (Retract) key are turned on.

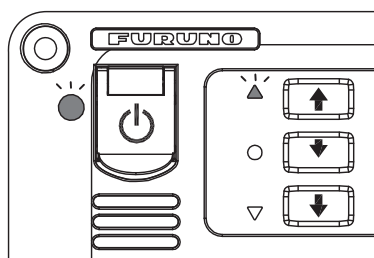

3. ADJUSTMENTS

- Confirm that the “3.3V” and “UP” LEDs on the control box are on.

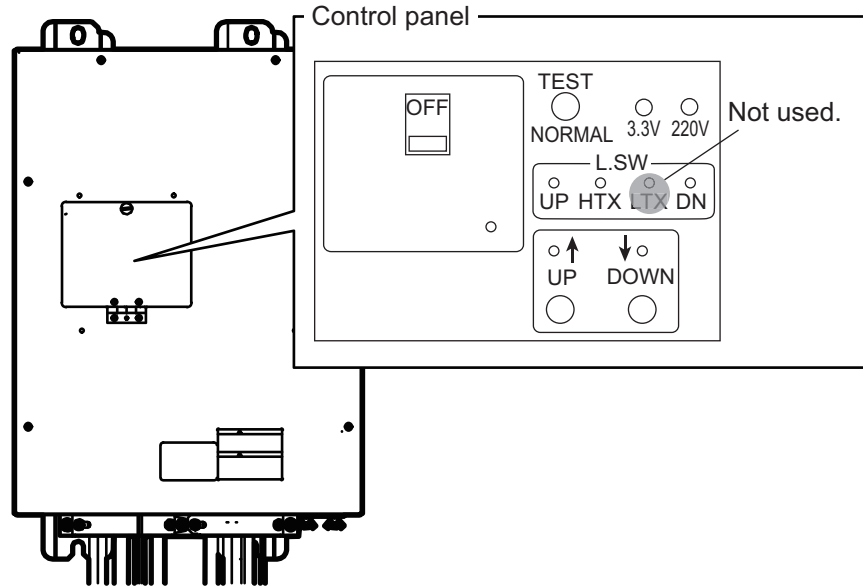

- Remove the control box cover and check the terminal voltage as shown in the following table.

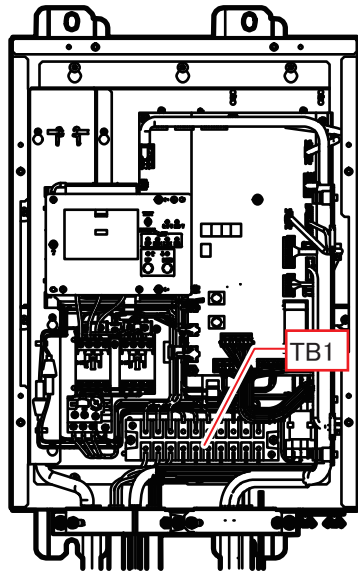

Terminal block	Terminal No.	Voltage
TB1	(1) - (2)	220 VAC
	(2) - (3)	220 VAC
	(1) - (3)	220 VAC

- Set the **TEST/NORMAL** switch on the control panel to [TEST], then press the **DOWN** switch to confirm that the transducer lowers. Also, while the transducer is being lowered, check that the “HTX” LED lights when the TX limit switch is passed by the transducer shaft.
Note: The TX limit switch does not stop the transducer when the **TEST/NORMAL** switch is in the [TEST] position.
- Release the **DOWN** switch during lowering to confirm that the transducer stops lowering.

6. Press the **DOWN** switch again to continue lowering.
While the transducer is lowering, press the EMERGENCY STOP button, then confirm that the transducer has stopped. After confirming that the transducer has stopped, turn the EMERGENCY STOP button to release the transducer.

7. Press the **DOWN** switch again to continue lowering.
While the transducer is lowering, press the lower limit switch, then confirm that the transducer has stopped.

8. Press the **UP** switch to raise the transducer and conduct the same tests as when lowering.

9. Remove the ratchet wrench from its holder on the top of the hull unit. Press the **UP** switch, then the **DOWN** switch to make sure the hull unit does not move. Once you have confirmed there is no movement in the hull unit, place the ratchet wrench back in its holder.

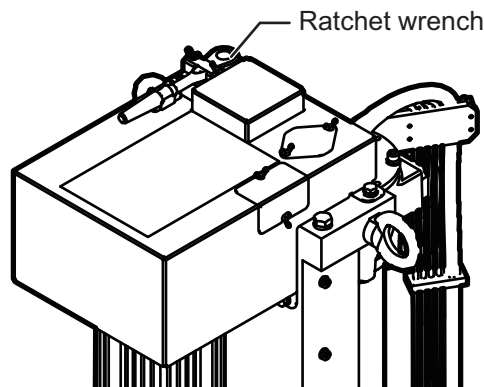
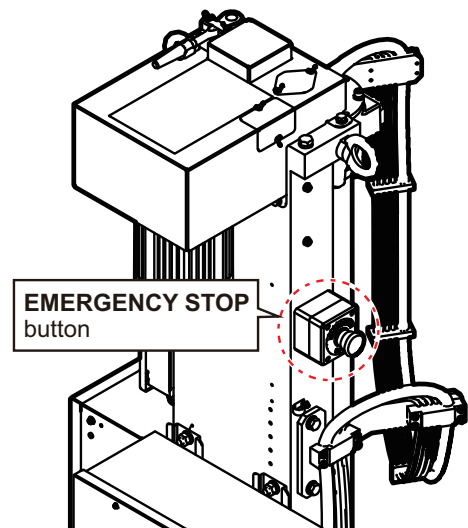

10. Check the following items in the control panel:
- Each of the LEDs, for UP, HTX and DN, light when their respective limit switch is pressed.
 - “UP” LED lights when the **UP** switch is pressed.
 - “DOWN” LED lights when the **DOWN** switch is pressed.
11. After the above tests are completed, switch the **TEST/NORMAL** switch back to [NORMAL] on the control panel.
12. Press the ▼ (mid-protrusion) key and check that the hull unit is lowered to the half-way point.
While lowering, check that the LED on the left of the ▼ (mid-protrusion) key is flashing, the limiter makes a short beep sound and once the shaft stops at half-protrude the LED lights constantly.
13. Using the same method, check that the ▼ (Full-protrude) key and ▲ (Retract) key LEDs flash and light constantly and that the limit switch beeps.
14. Press the power switch on the control unit to turn the power off and check that the transducer is retracted automatically. At full retraction, check that the power is off.

3.5 How to Adjust the Heading

Adjust the heading so an echo which is dead ahead appears dead ahead on the display as follows:

Note: The transducer should be aligned with the bow at installation (see section 1.2.9). This procedure provides finer adjustments to the alignment.

1. Enable transmission as shown in section 3.4.
2. Find a target in the bow direction (buoy, for example) and display it on a near range. If the target appears at 12 o'clock the heading alignment is correct. If it does not, measure the error and go to the next step.

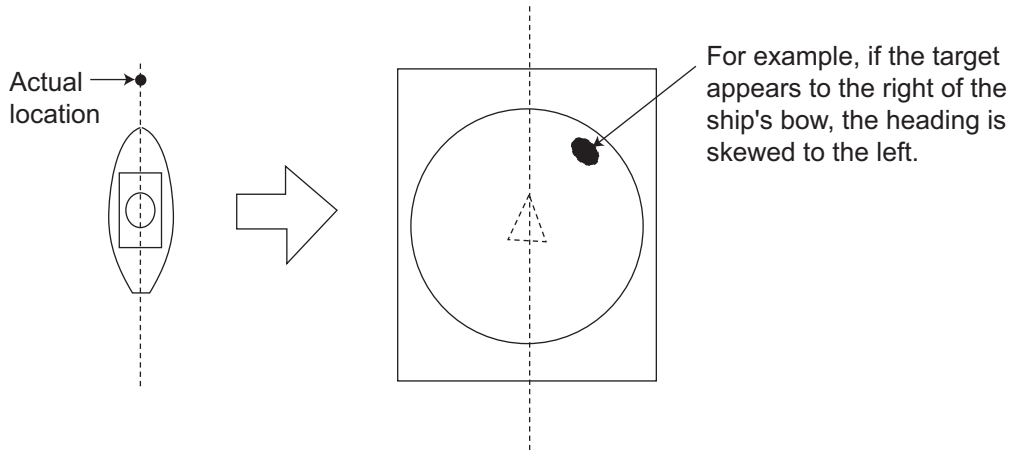

3. If the heading is skewed, measure the skew angle.
4. Press the **MENU/ESC** key to open the menu.
5. Select [9 Installation Setting].
A confirmation message appears.
6. Select [OK].
7. Select [4 Hull Unit Setting].
8. Select [3 Heading Adjust 1].
9. Adjust the setting so that the target selected at step 2 appears at the 12 o'clock position on-screen. A positive value corrects the heading in the clockwise (right) direction, a negative value corrects in the anti-clockwise (left) direction.

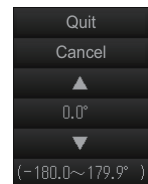

Note: Heading alignment also changes the turning range of the transducer. When the heading is not adjusted ([3 Heading Adjust 1] = [0°]), the turning range is -175° to +175°. For example, if [3 Heading Adjust 1] is set to [-20°], the turning range is also changed to -195° to +155°.

10. Select [Quit].
11. Select [4 Heading Adjust 2].

12. Adjust the direction offset of the motion sensor.
The [Reference Direction] mark on the motion sensor should face the ship's bow.
For example, when the mark is skewed 2° in the starboard direction, enter "+2°".

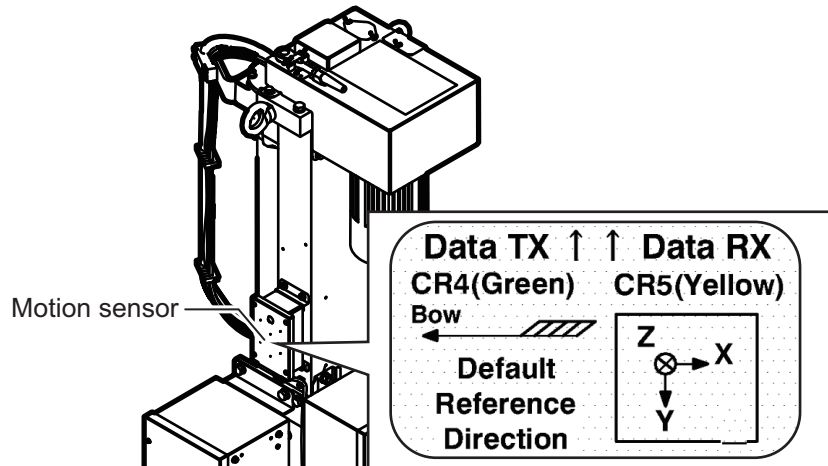

13. Select [Quit].
14. Press and hold the **MENU/ESC** key to close the menu.

3.6 How to Set the Stroke of the Hull Unit

Select the stroke (length) of your hull unit as follows.

1. Press the **MENU/ESC** key to open the menu.
2. Select [9 Installation Setting].
A confirmation message appears.
3. Select [OK].
4. Select [4 Hull Unit Setting].
5. Select [5 Hull Unit Stroke].
6. Select [600/800 mm] or [1100 mm].
7. Select [Quit].
8. Press and hold the **MENU/ESC** key to close the menu.

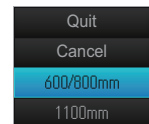

3.7 How to Configure the Own Ship Mark

To show the own ship mark accurately on-screen, set your ship's dimensions and the position of the transducer with the following procedure.

1. Press the **MENU/ESC** key to open the menu.
2. Select [9 Installation Setting].
A confirmation message appears.
3. Select [OK].
4. Select [7 Own Ship Data].

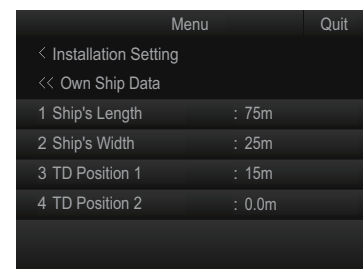

3. ADJUSTMENTS

5. Adjust each setting item.

- [Ship's Length]: The length of the ship.
- [Ship's Width]: The width of the ship at its widest point.
- [TD Position 1]: Distance from transducer to bow.
- [TD Position 2]: Distance from transducer to keel. Set a positive value for starboard installations, a negative value for port installations.

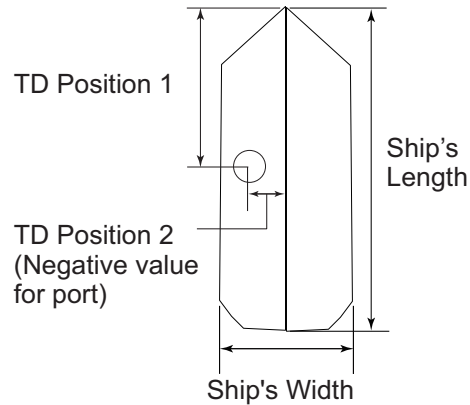

6. Press and hold the **MENU/ESC** key to close the menu.

3.8 How to Set Up a Secondary Monitor

When a secondary monitor is connected, use the following procedure to adjust the display settings.

1. Press the **MENU/ESC** key to open the menu.
2. Select [9 Installation Setting].
A confirmation message appears.
3. Select [OK].
4. Select [1 Display Setting].

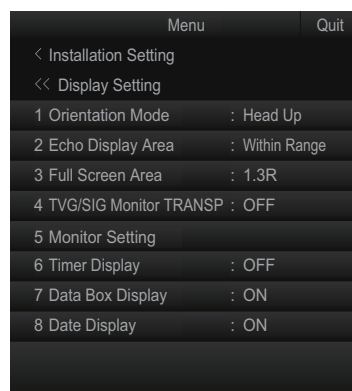

5. Select [5 Monitor Setting].

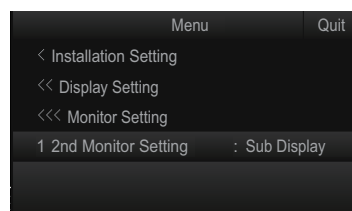

6. Select [1 2nd Monitor Setting].

7. Select [Dual Display] or [Sub Display] as appropriate.
 - [Dual Display]: Displays the full-screen slant mode display on the Sub monitor. Note that numeric/graphic data is not displayed on the Sub monitor.
 - [Sub Display]: Displays the same screen as the Main monitor
 When there is no secondary monitor connected, set this option to [OFF].
8. Select [Quit].
The following confirmation message appears.

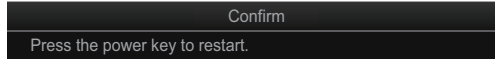
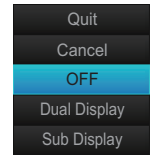

9. Restart the system to apply the setting.

3.9 How to Export/Import Backup Data

3.9.1 How to export the backup data

Export the backup data to an external media as follows:

Note: Data backup requires the connection of an external media to the processor unit.

1. With the **MENU/ESC** key pressed and held, press **1/F1**, **3/F3**, **5/F5** in order.
The system menu items appear on the main menu. Repeat the above procedure to hide the system menu items.
2. Press the **MENU/ESC** key to open the menu.

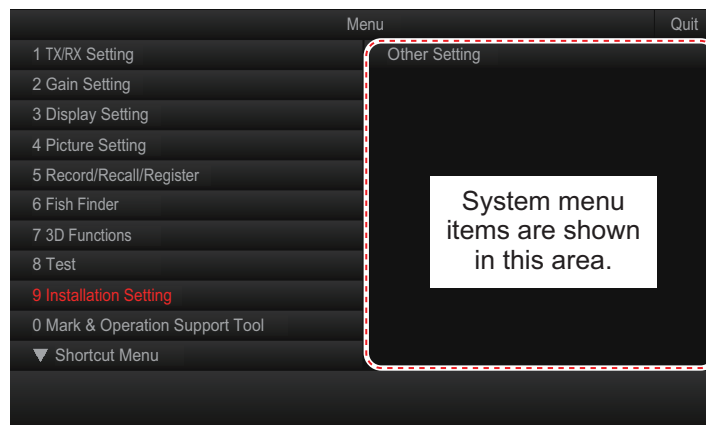

3. Select [Other Setting].

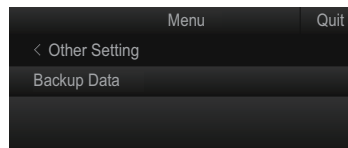

4. Select [Backup Data].

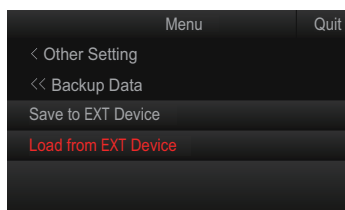

3. ADJUSTMENTS

5. Select [Save to EXT Device].
The following message appears.

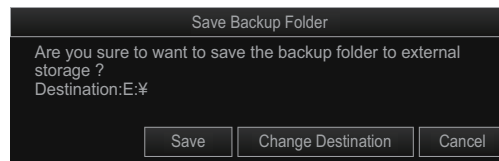

6. Select [Change Destination].

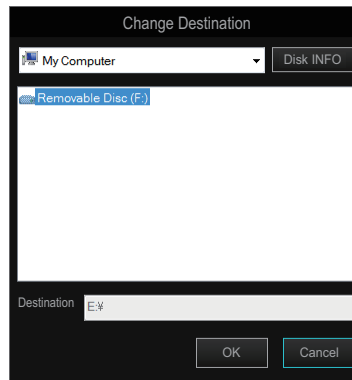

7. Specify the destination for the backup data, then click [OK].
8. Select [Save].
The backup data is saved to the specified destination.
9. Press and hold the **MENU/ESC** key to close the menu.
10. With the **MENU/ESC** key pressed and held, press **1/F1**, **3/F3**, **5/F5** in order to hide the system menu items.

Note: The error message "Disk space insufficient. Delete unnecessary files." appears if the save destination does not have sufficient space for the backup data. If this occurs, select [Delete Data] to delete unnecessary files, then repeat the above procedure.

3.9.2 How to import the backup data

Note: Data import requires the connection of an external media to the processor unit.

1. With the **MENU/ESC** key pressed and held, press **1/F1**, **3/F3**, **5/F5** in order.
The system menu items appear on the main menu. Repeat the above procedure to hide the system menu items.
2. Press the **MENU/ESC** key to open the menu.
3. Select [Other Setting].
4. Select [Backup Data].
5. Select [Load from EXT Device].
The following message appears.

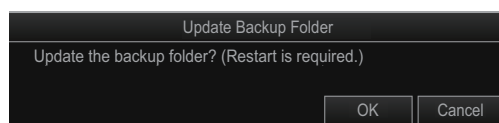

6. Select [OK].

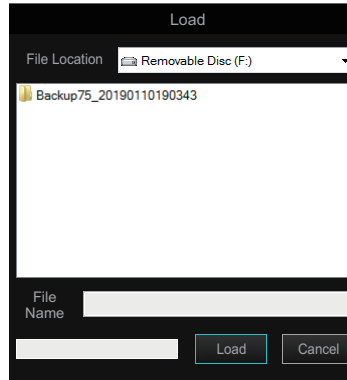

7. Select the backup folder to load, then click [Load].
The following confirmation message appears.

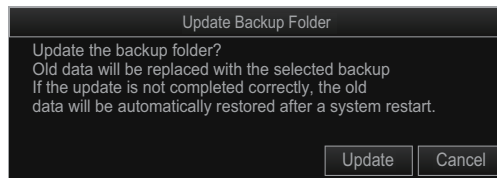

8. Select [Update].
A confirmation message appears.
Note: Previous (old) backup data saved in the processor unit is overwritten and replaced when data is imported from an external source.
9. Restart the system to apply the setting.

3.10 How to Backup/Load All Settings

3.10.1 How to backup all settings

You can backup all your menu settings (except language, IP address, date and time, oil replacement date, motor running time) with the following procedure.

1. Press the **MENU/ESC** key to open the menu.
2. Select [5 Record/Recall/Register].
3. Select [8 Setting File].
4. Select [4 Save Ship's Original].
The message "Are you sure to execute this item?" appears.
5. Select [Yes].
The file name, which appears in the [File Name] box, is automatically assigned as shown below.
FSV75_OriginalFile_yyyy_mm_dd_hh_mm_ss.ini

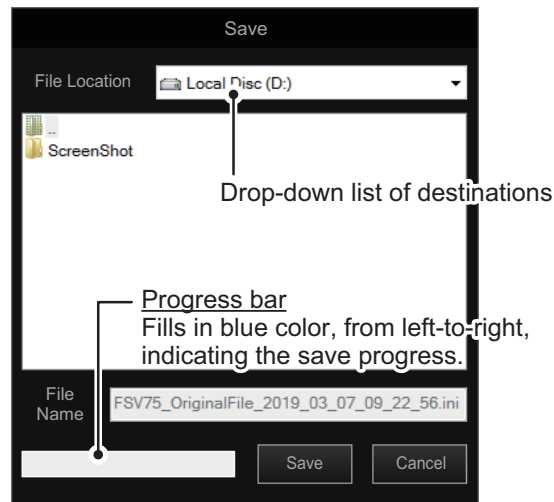

6. Select where to save the setting data, from the drop-down list of destinations.
7. Select [Save].
The progress bar shows the saving progress. After the settings are saved, the [Setting File] menu appears.
8. Press and hold the **MENU/ESC** key to close the menu.

Note: The error message "Disk space insufficient. Delete unnecessary files." appears if the save destination does not have sufficient space (a minimum of 500MB is required). If this occurs, select [Delete Data] to delete unnecessary files, then repeat the above procedure.

3.10.2 How to load backed-up settings

1. Press the **MENU/ESC** key to open the menu.
2. Select [5 Record/Recall/Register].
3. Select [8 Setting File].
4. Select [5 Recall Ship's Original].
The message "Are you sure to execute this item? (Restart is required)" appears.

5. Select [Yes].

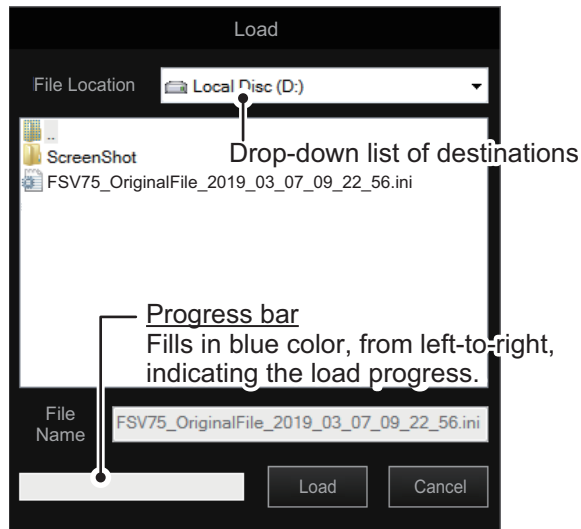

6. Select the file to load, from the drop-down list of destinations. The selected file appears in the [File Name] field.
7. Select [Load].
The progress bar shows the loading progress. After the settings are loaded, the message “Press the power key to restart.” appears.
8. Restart the system to apply the setting.

3.11 How to Change the IP Address for the Processor Unit and Transceiver Unit

To change the IP address for the processor unit and transceiver unit, do as follows:

Note: Only change the IP address when necessary. IP address changes may cause network errors.

1. With the **MENU/ESC** key pressed and held, press **1/F1**, **3/F3**, **5/F5** in order. The system menu items appear on the main menu. Repeat the above procedure to hide the system menu items.
2. Press the **MENU/ESC** key to open the menu.
3. Select [9 Installation Setting].
A confirmation message appears.
4. Select [OK].

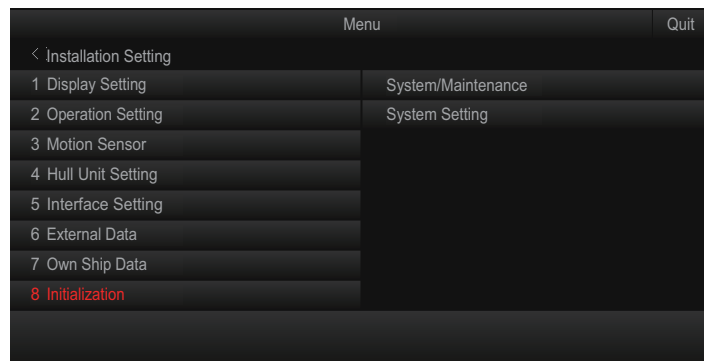

3. ADJUSTMENTS

5. Select [System Setting].

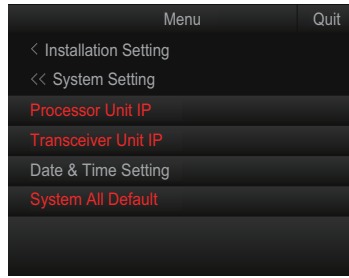

6. Select [Processor Unit IP] or [Transceiver Unit IP].
The following message appears.

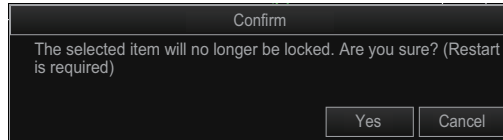

7. Select [Yes].
8. Adjust the setting value, then select [Quit].
The confirmation message appears.
9. Restart the system to apply the setting.

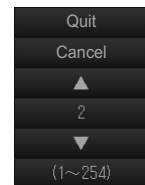

3.12 How to Set the System Time

Set the system time as follows:

1. With the **MENU/ESC** key pressed and held, press **1/F1**, **3/F3**, **5/F5** in order.
The system menu items appear on the main menu. Repeat the above procedure to hide the system menu items.
2. Press the **MENU/ESC** key to open the menu.
3. Select [9 Installation Setting].
A confirmation message appears.
4. Select [OK].
5. Select [System Setting].
6. Select [Date & Time].
7. Set the time, date and timezone as required.
Note: When the timezone setting is changed, the message "Press the power key to restart." appears.
Restart the system to apply the setting.
8. Press and hold the **MENU/ESC** key to close the menu.
9. With the **MENU/ESC** key pressed and held, press **1/F1**, **3/F3**, **5/F5** in order to hide the system menu items.

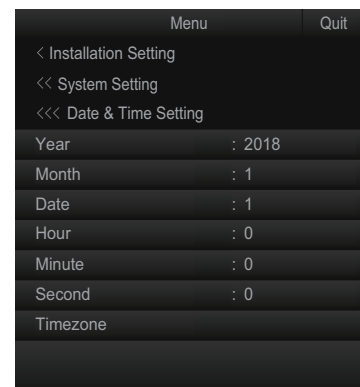

3.13 How to Restore Factory Default

Do as follows to restore factory default settings:

1. With the **MENU/ESC** key pressed and held, press **1/F1**, **3/F3**, **5/F5** in order.
The system menu items appear on the main menu. Repeat the above procedure to hide the system menu items.
2. Press the **MENU/ESC** key to open the menu.
3. Select [9 Installation Setting].
A confirmation message appears.
4. Select [OK].
5. Select [System Setting].
6. Select [System All Default].
The following confirmation message appears.

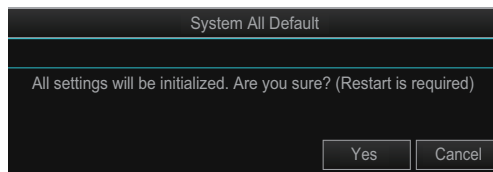

7. Select [Yes] to restore factory default settings.
The following confirmation message appears.

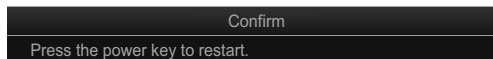

8. Restart the system to apply the setting.

3.14 Error Code List

The error code list shows the possible errors for this equipment.

Do as follows to open the error code list.

1. With the **MENU/ESC** key pressed and held, press **1/F1**, **3/F3**, **5/F5** in order.
The system menu items appear on the main menu. Repeat the above procedure to hide the system menu items.
2. Press the **MENU/ESC** key to open the menu.
3. Select [9 Installation Setting].
A confirmation message appears.
4. Select [OK].
5. Select [System/Maintenance].

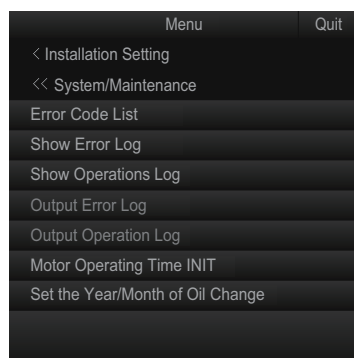

Not used at installation.
These menu items are for
developer/technicians.

3. ADJUSTMENTS

6. Select [Error Code List].
The error code list appears.

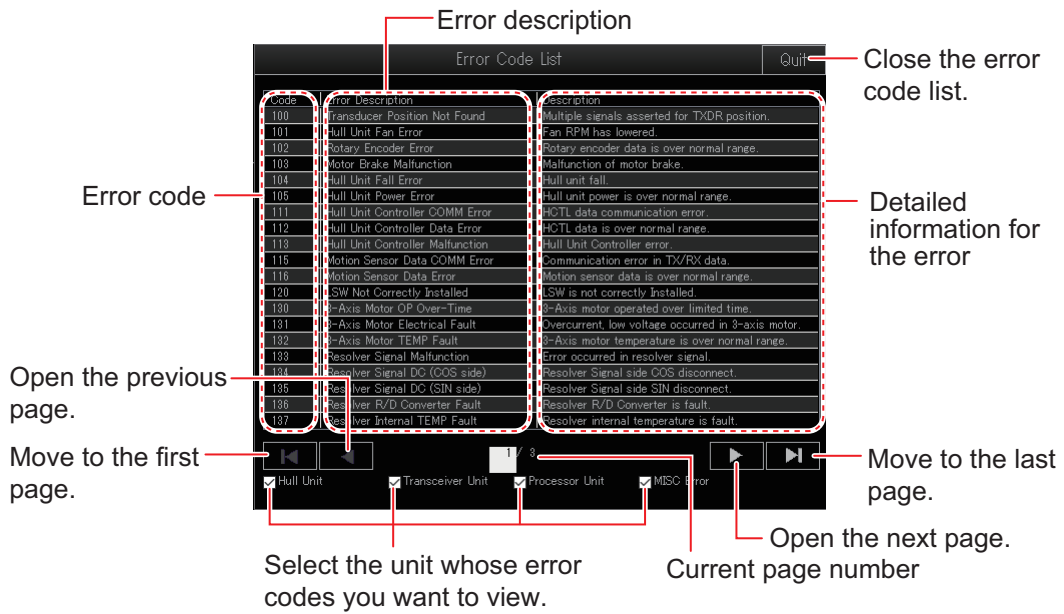

3.15 How to Register Motor Operating Times

The operating time for the rotation and pitch motors on the hull unit is recorded in the processor unit. Before replacing the processor unit, check the operating times on the current processor unit and transfer the values to the new processor unit.

How to check the motor operating times

Check the motor operating times before replacing the processor unit

1. Press the **MENU/ESC** key to open the menu.
2. Select [8 Test].

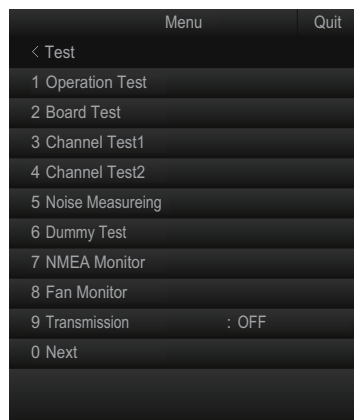

3. Select [0 Next].

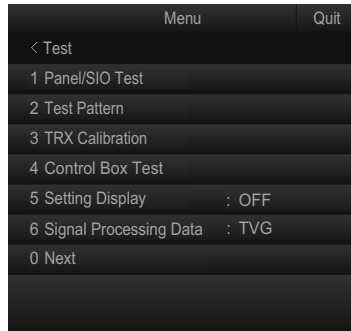

4. Select [4 Control Box Test].
5. Check the [ACTIVE TIME] value for [ROTATE MOTOR] and [PITCH MOTOR].
6. Press the **MENU/ESC** key to close the test screen.
7. Press and hold the **MENU/ESC** key to close the menu.

Registering the motor operating times

Register the motor operating times as follows:

1. With the **MENU/ESC** key pressed and held, press **1/F1**, **3/F3**, **5/F5** in order. The system menu items appear on the main menu. Repeat the above procedure to hide the system menu items.
2. Press the **MENU/ESC** key to open the menu.
3. Select [9 Installation Setting]. A confirmation message appears.
4. Select [OK].
5. Select [System/Maintenance].
6. Select [Motor Operating Time INIT].

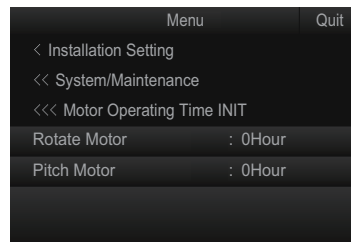

7. Select [Rotate Motor].
8. Register the operating time for the rotation motor, as recorded at "How to check the motor operating times" on page 3-18.
9. Select [Quit] on the setting box.
10. Similarly, register the operation time for the pitch motor ([Pitch Motor]).
11. Press and hold the **MENU/ESC** key to close the menu.
12. With the **MENU/ESC** key pressed and held, press **1/F1**, **3/F3**, **5/F5** in order to hide the system menu items.

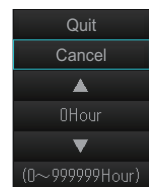

3.16 How to Set the Year/Month of Oil Change

The year and month at which the sonar oil is either filled (at installation) or replaced must be set within the menu. Also, if the processor unit is replaced, the year and month must be transferred to the new processor unit.

Set the year and month of oil change as follows:

1. With the **MENU/ESC** key pressed and held, press **1/F1**, **3/F3**, **5/F5** in order. The system menu items appear on the main menu. Repeat the above procedure to hide the system menu items.
2. Press the **MENU/ESC** key to open the menu.
3. Select [9 Installation Setting].
A confirmation message appears.
4. Select [OK].
5. Select [System/Maintenance].
6. Select [Set the Year/Month of Oil Change].

Note: When replacing the processor unit, the year and date shown in this menu must be transferred to the new processor unit.

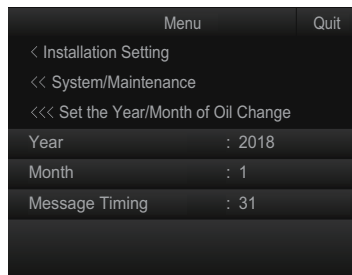

7. Select [Year].
8. Set the year of the sonar oil change.
9. Select [Quit] on the setting box.
10. Select [Month].
11. Set the month of the sonar oil change.
12. Select [Quit] on the setting box.
13. Select [Message Timing].
14. Set the message timing (unit: month).
A message, notifying the operator that oil replacement is required, appears on-screen when the months set here has passed from the date set in this menu. When [Message Timing] is set to "0", the notifying message does not appear.
15. Select [Quit] on the setting box.
16. Press and hold the **MENU/ESC** key to close the menu.
17. With the **MENU/ESC** key pressed and held, press **1/F1**, **3/F3**, **5/F5** in order to hide the system menu items.

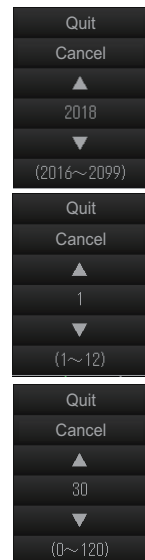

3.17 [Installation Setting] Menu

This section explains the menu items on the [Installation Setting] menu.

3.17.1 How to open the [Installation Setting] menu

1. Press the **MENU/ESC** key to open the menu.

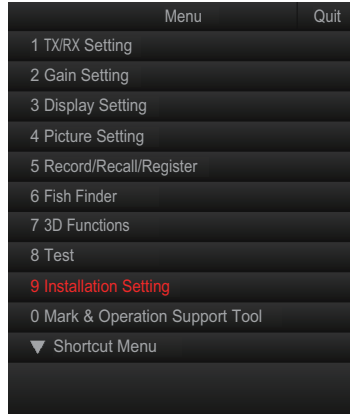

2. Select [9 Installation Setting].
The following confirmation message appears.

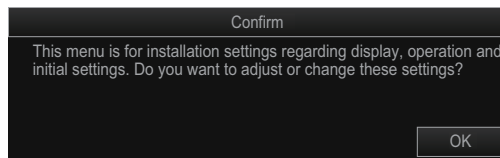

3. Select [OK].

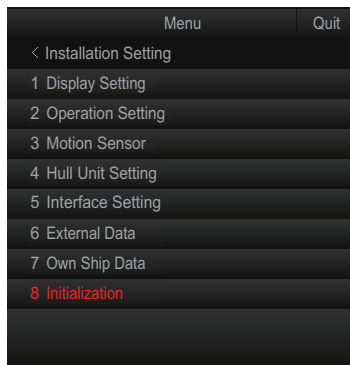

3. ADJUSTMENTS

3.17.2 [Display Setting] menu

The [Display Setting] menu sets various display-related items according to operator's preference. To display this menu, select [1 Display Setting] from the [Installation Setting] menu.

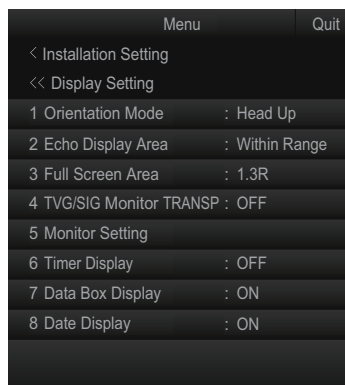

Menu item	Remarks
[1 Orientation Mode]	Selects the orientation mode, among [Head-up], [North-up], [Course-up].
[2 Echo Display Area]	Selects the echo display mode, [Within Range] or [Full Screen].
[3 Full Screen Area]	Used when [2 Echo Display Area] is set to [Full Screen]. Expands the detection range and shows echoes outside the normal display area. Options are [1.3R], [1.6R], [1.9R] (R = ratio of increase in relation to currently selected range).
[4 TVG/SIG Monitor TRANSP]	Turns on/off the TVG monitor transparency.
[5 Monitor Setting]	Settings for the secondary monitor. For details, section 3.8.
[6 Timer Display]	Shows or hides the timer display, which appears at the bottom left of the display.
[7 Data Box Display]	Shows or hides the Numeric/Graphic display.
[8 Date Display]	Shows or hides the date display which appears at the bottom of the Numeric/Graphic display.

3.17.3 [Operation Setting] menu

Several operation items can be customized to suit your needs from the [Operation Setting] menu. To display this menu, select [2 Operation Setting] from the [Installation Setting] menu.

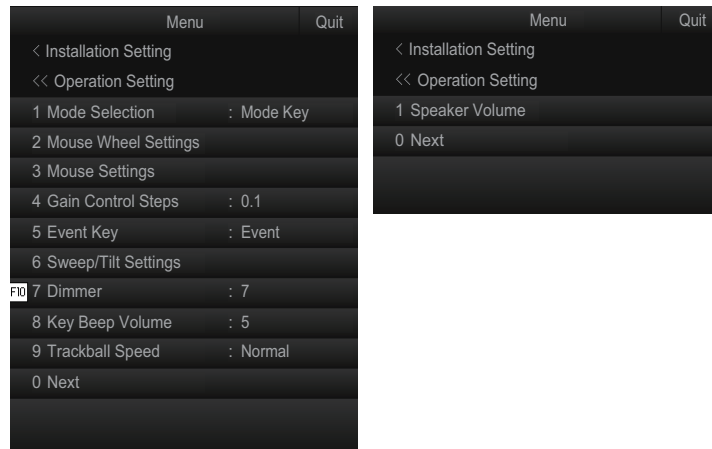

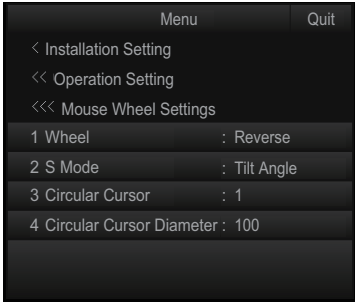
Menu item	Remarks
[1 Mode Selection]	<p>Determines how display modes are selected.</p> <ul style="list-style-type: none"> • [Mode Key]: Press the DISP MODE key to cycle the display mode. • [Pull-Down Menu]: When the DISP MODE key is pressed, the pull-down menu appears for mode selection.
[2 Mouse Wheel Settings]	<p>Sets items related to scrollwheel operation. Left-click this item to show its setting menu.</p>  <ul style="list-style-type: none"> • [1 Wheel]: Sets how the settings are applied to tilt angle, detection range, gain, turn angle and user program number selection. <ul style="list-style-type: none"> • [Normal]: Scroll upward to decrease, downward to increase values. • [Reverse]: Reverse of [Normal]. • [2 S Mode]: Programs a function to the scrollwheel. The choices are [Tilt Angle], [Range], [Gain] or [Sweep]. • [3 Circular Cursor]: Adjusts the amount of variation of the circle cursor (1 - 9). • [4 Circular Cursor Diameter]: Sets the default diameter of the circle cursor (10 - 2000 m).

3. ADJUSTMENTS

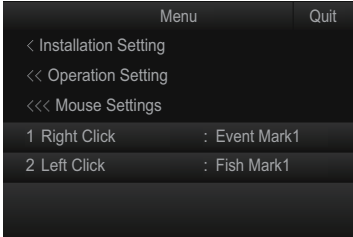
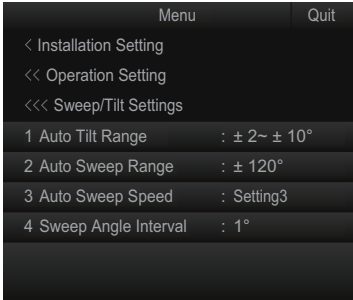
Menu item	Remarks
[3 Mouse Settings]	<p>Select the function to be assigned to the left and right button on the trackball from [Fish Mark1], [Fish Mark2], [Event Mark1], [Event Mark2], [Estimate Mark1] or [Estimate Mark2].</p> 
[4 Gain Control Steps]	Sets the amount of change with each interval on the GAIN knob (setting range: [0.1], [0.2], [0.5]).
[5 Event Key]	Sets the key to use to enter an own ship position mark, [Event] or [Shoot].
[6 Sweep/Tilt Settings]	<p>Sets the sector and tilt angle. Select this item to show its setting menu.</p>  <ul style="list-style-type: none"> • [1 Auto Tilt Range]: Selects the auto range, [$\pm 2^\circ \sim \pm 10^\circ$], [$\pm 4^\circ \sim \pm 16^\circ$], [$\pm 6^\circ \sim \pm 20^\circ$], [$\pm 2^\circ$ (Fixed)], [$\pm 4^\circ$ (Fixed)], [$\pm 8^\circ$ (Fixed)], [$\pm 16^\circ$ (Fixed)]. • [2 Auto Sweep Range]: Selects the auto sweep range, [$\pm 30^\circ$], [$\pm 60^\circ$], [$\pm 90^\circ$], [$\pm 120^\circ$]. • [3 Auto Sweep Speed]: Selects the auto sweep speed (setting range [Setting1] to [Setting5]). The larger the setting number the faster the sweep speed. • [4 Sweep Angle Interval]: Sets the sweep angle intervals for manual operation, [1°], [3°], [5°], [7°], [10°].
[7 Dimmer]	Adjusts the illumination of the control unit operation panel (setting range: 0 to 15).
[8 Key Beep Volume]	Sets the volume of the beep which sounds for key operation (setting range: 0 to 7).
[9 Trackball Speed]	Sets the tracking speed of the trackball, [Slow], [Normal], [Fast].
[1 Speaker Volume]	Sets the volume of the internal speaker. Drag the volume bar up to increase, or down to decrease, the volume. To silence the audio, click the check-box at [Mute] to show a check-mark.

3.17.4 [Motion Sensor] menu

You can offset the pitch and roll angle for the motion sensor on the [Motion Sensor] menu. To display this menu, select [3 Motion Sensor] from the [Installation Setting] menu.

Note: This setting is only required if the motion sensor is installed separately from the hull unit.

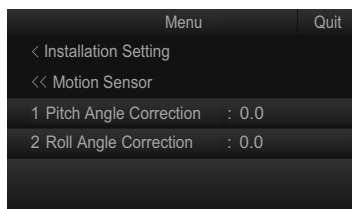





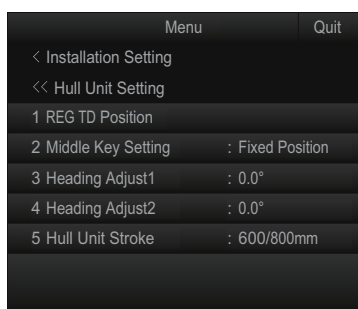

Menu item	Remarks
[1 Pitch Angle Correction]	Offsets the pitch angle at the motion sensor.
[2 Roll Angle Correction]	Offsets the roll angle at the motion sensor.

3.17.5 [Hull Unit Setting] menu

You can setup information about the hull unit on the [Hull Unit Setting] menu. To display this menu, select [4 Hull Unit Setting] from the [Installation Setting] menu.



Menu item	Remarks
[1 REG TD Position]	Registers the transducer position. For details, see section 3.3.
[2 Middle Key Setting]	<p>Sets the operation when the  (mid-protrusion) key is pressed.</p> <ul style="list-style-type: none"> [Fixed Position]: The transducer stops at the selected position. If the  (mid-protrusion) key is operated the transducer is being raised or lowered, the transducer stops at the fixed position. [Any Position]: The transducer starts lowering when  (Full-protrude) key is operated. The lowering is stopped when the  (mid-protrusion) key is operated. To raise or lower the transducer from the current position, use the  (Retract) or  (Full-protrude) key. The  (mid-protrusion) key does not control lowering or raising of the transducer.
[3 Heading Adjust1]	Offsets the transducer heading. For details, see section 3.5.
[4 Heading Adjust2]	Offsets the motion sensor heading. For details, see section 3.5.
[5 Hull Unit Stroke]	Selects the stroke (length) of the hull unit ([600/800 mm] or [1100 mm]).

3. ADJUSTMENTS

3.17.6 [Interface Setting] menu

Set the transmission rate for the NMEA ports on the [Interface Setting] menu. To display this menu, select [5 Interface Setting] from the [Installation Setting] menu.

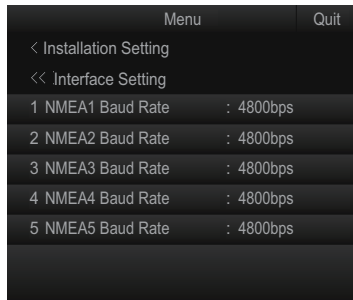

Menu item	Remarks
[1 NMEA1 Baud Rate]	Set the transmission rate for each NMEA port (setting range: [4800bps], [9600bps], [19200bps], [38400bps]).
[2 NMEA2 Baud Rate]	
[3 NMEA3 Baud Rate]	
[4 NMEA4 Baud Rate]	
[5 NMEA5 Baud Rate]	

3.17.7 [External Data] menu

Select the input format for external data on the [External Data] menu. To display this menu, select [6 External Data] from the [Installation Setting] menu.

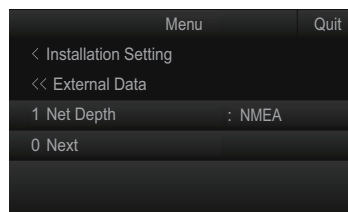
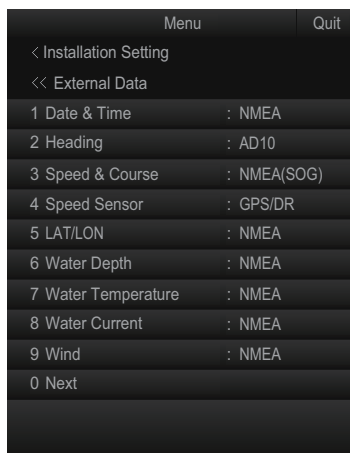

Menu item	Remarks
[1 Date & Time]	Sets the input format for date and time data (setting range: [Disable], [NMEA]).
[2 Heading]	Sets the input format for heading data (setting range: [Disable], [AD10], [NMEA]).
[3 Speed & Course]	Sets the input format for ship's speed and course data (setting range: [Disable], [NMEA (SOG)], [NMEA (STW)]).
[4 Speed Sensor]	Sets the type of device which is used as the speed and course data source (setting range: [Disable], [GPS/DR], [Doppler/DR]).
[5 LAT/LON]	Sets the input format for position data (setting range: [Disable], [NMEA]).
[6 Water Depth]	Sets the input format for water depth (setting range: [Disable], [NMEA]).
[7 Water Temperature]	Sets the input format for water temperature (setting range: [Disable], [NMEA]).

Menu item	Remarks
[8 Water Current]	Sets the input format for water current (setting range: [Disable], [NMEA]).
[9 Wind]	Sets the input format for wind data (setting range: [Disable], [NMEA]).
[1 Net Depth]	Sets the input format for net depth data (setting range: [Disable], [NMEA]).

3.17.8 [Own Ship Data] menu

Enter the own ship's information on the [Own Ship Data] menu. To display this menu, select [7 Own Ship Data] from the [Installation Setting] menu.

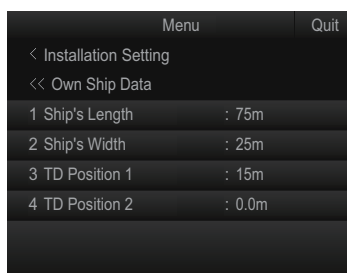

Menu item	Remarks
[1 Ship's Length]	Sets the length of the ship.
[2 Ship's Width]	Sets the width of the ship at its widest point.
[3 TD Position 1]	Sets the distance from transducer to bow.
[4 TD Position 2]	Sets the distance from transducer to keel. Set a positive value for starboard installations, a negative value for port installations.

3.17.9 [Initialization] menu

You can change the language setting and restore factory default on the [Initialization] menu. To display this menu, select [8 Initialization] from the [Installation Setting] menu.

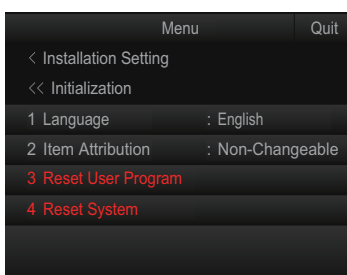

Note: When you select [8 Initialization] from the [Installation Setting] menu, the following confirmation message appears. Select [OK] to open the [Initialization] menu.

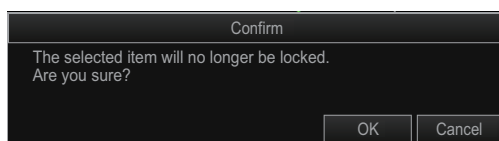

3. ADJUSTMENTS

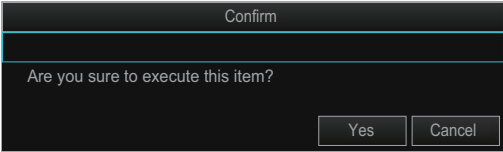
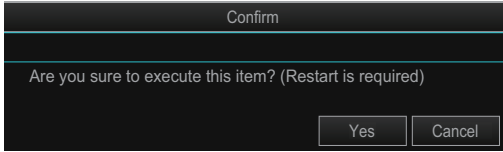
Menu item	Remarks
[1 Language]	Sets the language to use.
[2 Item Attribution]	<p>When a protected menu item (in red) is clicked, you are asked if you want to display a confirmation message to enable settings changes. However, the following menu items display the confirmation message regardless of this setting.</p> <ul style="list-style-type: none"> • [Installation Setting] menu • [4 Ship Speed Alarm] in the [Alarm & Audio] menu • [3 Reset User Program] in the [Initialization] menu • [4 Reset System] in the [Initialization] menu
[3 Reset User Program]	<p>Restores all user programs to their default settings. When [3 Reset User Program] is selected, the following message appears. Select [Yes] to restore the default settings.</p> 
[4 Reset System]	<p>Restore all settings other than the following menu items to default settings:</p> <ul style="list-style-type: none"> • Language setting • IP Address • System Time • Year/Month of oil change • Motor operating time <p>When [4 Reset System] is selected, the following message appears. Select [Yes] to restore factory settings. After selecting [Yes], the message "Press the power key to restart." appears. Restart the system to apply the settings.</p> 

APPENDIX 1 JIS CABLE GUIDE

Cables listed in the manual are usually shown as Japanese Industrial Standard (JIS). Use the following guide to locate an equivalent cable locally.

JIS cable names may have up to 6 alphabetical characters, followed by a dash and a numerical value (example: DPYC-2.5).

For core types D and T, the numerical designation indicates the *cross-sectional Area (mm²)* of the core wire(s) in the cable.

For core types M and TT, the numerical designation indicates the *number of core wires* in the cable.

1. Core Type

D: Double core power line

T: Triple core power line

M: Multi core

TT: Twisted pair communications
(1Q=quad cable)

2. Insulation Type

P: Ethylene Propylene Rubber

3. Sheath Type

Y: PVC (Vinyl)

4. Armor Type

C: Steel

5. Sheath Type

Y: Anticorrosive vinyl sheath

6. Shielding Type

SLA: All cores in one shield, plastic tape w/aluminum tape

-SLA: Individually shielded cores, plastic tape w/aluminum tape



DPYC



TPYC

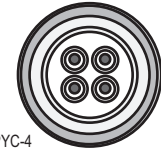

MPYC-4



TTYCSLA-4

EX: ^{1 2 3 4 5 6} TTYC Y S L A - 4
 Designation type | # of twisted pairs

EX: ^{1 2 3 4} M P Y C - 4
 Designation type | # of cores

The following reference table lists gives the measurements of JIS cables commonly used with Furuno products:

Type	Core		Cable Diameter	Type	Core		Cable Diameter
	Area	Diameter			Area	Diameter	
DPYC-1.5	1.5mm ²	1.56mm	11.7mm	TTYCSLA-1	0.75mm ²	1.11mm	9.4mm
DPYC-2.5	2.5mm ²	2.01mm	12.8mm	TTYCSLA-1T	0.75mm ²	1.11mm	10.1mm
DPYC-4	4.0mm ²	2.55mm	13.9mm	TTYCSLA-1Q	0.75mm ²	1.11mm	10.8mm
DPYC-6	6.0mm ²	3.12mm	15.2mm	TTYCSLA-4	0.75mm ²	1.11mm	15.7mm
DPYC-10	10.0mm ²	4.05mm	17.1mm	TTYCY-1	0.75mm ²	1.11mm	11.0mm
DPYCY-1.5	1.5mm ²	1.56mm	13.7mm	TTYCY-1T	0.75mm ²	1.11mm	11.7mm
DPYCY-2.5	2.5mm ²	2.01mm	14.8mm	TTYCY-1Q	0.75mm ²	1.11mm	12.6mm
DPYCY-4	4.0mm ²	2.55mm	15.9mm	TTYCY-4	0.75mm ²	1.11mm	17.7mm
MPYC-2	1.0mm ²	1.29mm	10.0mm	TTYCY-4SLA	0.75mm ²	1.11mm	19.5mm
MPYC-4	1.0mm ²	1.29mm	11.2mm	TTYCYSLA-1	0.75mm ²	1.11mm	11.2mm
MPYC-7	1.0mm ²	1.29mm	13.2mm	TTYCYSLA-4	0.75mm ²	1.11mm	17.9mm
MPYC-12	1.0mm ²	1.29mm	16.8mm				
TPYC-1.5	1.5mm ²	1.56mm	12.5mm				
TPYC-2.5	2.5mm ²	2.01mm	13.5mm				
TPYC-4	4.0mm ²	2.55mm	14.7mm				
TPYCY-1.5	1.5mm ²	1.56mm	14.5mm				
TPYCY-2.5	2.5mm ²	2.01mm	15.5mm				
TPYCY-4	4.0mm ²	2.55mm	16.9mm				

APPENDIX 2 INSTALLATION CHECK LIST

After completing the installation, perform the following checks:

Check point		Reference	Result
Hardware installation check			
Sonar oil	The dome is filled with the sonar oil.	section 1.9	<input type="checkbox"/>
O-ring in the retraction tank flange	O-ring, gasket* and insulation packing* are attached to the retraction tank flange. *: Attached only when the attachment kit or attachment flange is used.	section 1.2.5/ section 1.10.1/ section 1.10.2	<input type="checkbox"/>
Tank guide position at transducer full protrusion	Lower the transducer until fully protruded, then confirm that the rollers on the tank guide are not projected from the retraction tank. Tank guide must be positioned 30 mm inside from the bottom of the retraction tank.	-	<input type="checkbox"/>
Bow mark direction of the transducer	Confirm that the bow mark on the transducer faces the bow direction.	section 1.2.9	<input type="checkbox"/>
Soundome assembly operation check	Check the LEDs in the control box to perform the soundome assembly operation check.	section 1.2.10	<input type="checkbox"/>
Input voltage toggle switch on the transceiver unit	Input voltage toggle switches on the transceiver unit are changed correctly, depending on the input voltage.	section 2.3.3	<input type="checkbox"/>
Vibration and sound while raising/lowering the transducer	Confirm that abnormal vibration or noise is not generated from the hull unit while raising/lowering the transducer.	-	<input type="checkbox"/>
Software setting check			
Language setting	The language in which the menus and indications is changed as necessary.	section 3.2	<input type="checkbox"/>
Year/Month of oil change	Register the year and month of the sonar oil change.	section 3.16	<input type="checkbox"/>
Transducer position registration	The transducer position registration is completed.	section 3.3	<input type="checkbox"/>
Turn the transmission on	Change the transmission status from [OFF] to [ON].	section 3.4	<input type="checkbox"/>
Heading Correction	Adjust the heading so an echo which is dead ahead appears dead ahead on the display.	section 3.5	<input type="checkbox"/>
Direction offset of the motion sensor	Offset the direction difference between the [Reference Direction] mark on the motion sensor and bow direction.	section 3.5	<input type="checkbox"/>
Stroke setting	Select 800 mm or 1100 mm according to the stroke (length) of your hull unit.	section 3.6	<input type="checkbox"/>
External data setting	Set the baud rate for the NMEA2000 port and select the input format for external data.	section 3.17.6/ section 3.17.7	<input type="checkbox"/>
System time setting	Set the system time and time zone.	section 3.12	<input type="checkbox"/>
Save ship's original setting	Save all menu settings in the internal memory as necessary.	section 3.10	<input type="checkbox"/>

Check point		Reference	Result
Display setting for the numeric/graphic data display	Change the display setting for the numeric/graphic data display as appropriate.	Operator's manual	<input type="checkbox"/>
Function key setting	Assign the function to the function keys as necessary.	Operator's manual	<input type="checkbox"/>
Preset the horizontal mode ranges	Preset the horizontal mode ranges as selected with the RANGE control as necessary.	Operator's manual	<input type="checkbox"/>





PACKING LIST

FSV-752-180-T, FSV-753-180-T, FSV-754-180-T

100A-X-9857 -1

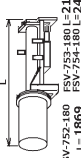
1/1

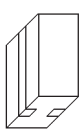
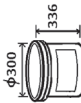
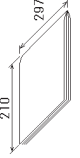
A-1

NAME	OUTLINE	DESCRIPTION/CODE No.	Q'TY
ユニット			
上下装置 HULL UNIT		FSV-75*-180-T 000-036-288-00 **	1
予備品			
予備品 SPARE PARTS		SP10-04401 001-539-770-00	1
現地組部品			
現地組部品箱詰品 HULL UNIT ASSEMBLY PARTS		FSV-75-T 001-541-090-00	1
工事材料			
工事材料 ギヤ油 GEAR OIL		SHC624 18.9L 000-196-208-10	1
図書			
装備要領書 INSTALLATION MANUAL		IM*-13630-* 000-195-869-1* **	1
装備時のご注意 NOTICE FOR INSTALLATION		C12-01801-* 000-195-859-1*	1 (*1)

コード番号末尾の[*]**は、選択品の代表コードを表します。
CODE NUMBER ENDING WITH * ** INDICATES THE CODE NUMBER OF REPRESENTATIVE MATERIAL.
(*1)は、上下装置に貼付けています。
(*1): ATTACHED TO THE HULL UNIT.

(略図の寸法は、参考値です。 DIMENSIONS IN DRAWING FOR REFERENCE ONLY.)

C1363-Z02-B



PACKING LIST

FSV-752-180-N, FSV-753-180-N, FSV-754-180-N

100A-X-9858 -1

1/1

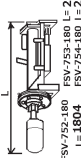
A-2

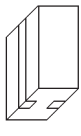
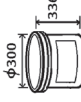
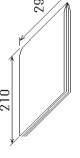
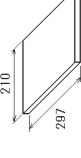
NAME	OUTLINE	DESCRIPTION/CODE No.	Q'TY
ユニット			
上下装置 HULL UNIT		FSV-75*-180-N 000-036-289-00 **	1
予備品			
予備品 SPARE PARTS		SP10-04401 001-539-770-00	1
現地組部品			
現地組部品箱詰品 HULL UNIT ASSEMBLY PARTS		FSV-75-N 001-541-100-00	1
工事材料			
工事材料 ギヤ油 GEAR OIL		SHC624 18.9L 000-196-208-10	1
図書			
装備要領書 INSTALLATION MANUAL		IM*-13630-* 000-195-869-1* **	1
装備時のご注意 NOTICE FOR INSTALLATION		C12-01801-* 000-195-859-1*	1 (*1)

コード番号末尾の[*]**は、選択品の代表コードを表します。
CODE NUMBER ENDING WITH * ** INDICATES THE CODE NUMBER OF REPRESENTATIVE MATERIAL.
(*1)は、上下装置に貼付けています。
(*1): ATTACHED TO THE HULL UNIT.

(略図の寸法は、参考値です。 DIMENSIONS IN DRAWING FOR REFERENCE ONLY.)



C1363-Z03-B

PACKING LIST

100A-X-9853 -0 1/1

FSV-7501-*

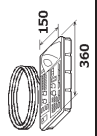
A-3

NAME	OUTLINE	DESCRIPTION/CODE No.	Q'TY
ユニット UNIT			
制御部 CONTROL UNIT		FSV-7501-* 000-036-271-00 **	1
工事材料 INSTALLATION MATERIALS			
KB取付金具 KB FIXTURE ASSEMBLY		CP03-33202 001-115-510-00	1
工事材料 INSTALLATION MATERIALS		CP10-09601 001-537-900-00	1

コード番号末尾の[**]は、選択品の代表コードを表します。
CODE NUMBER ENDING WITH "**" INDICATES THE CODE NUMBER OF REPRESENTATIVE MATERIAL.

(略図の寸法は、参考値です。DIMENSIONS IN DRAWING FOR REFERENCE ONLY.)





C1363-Z09-A

PACKING LIST

100A-X-9855 -4 1/1

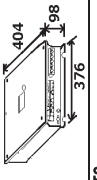
FSV-7503/-3D

A-4

NAME	OUTLINE	DESCRIPTION/CODE No.	Q'TY
ユニット UNIT			
制御部 PROCESSOR UNIT		FSV-7503* 000-036-273-00 **	1
予備品 SPARE PARTS			
予備品 SPARE PARTS		SP26-00301 001-080-860-00	1
工事材料 INSTALLATION MATERIALS			
ケーブル組品組 CABLE ASSY.		MJ-A3SPF0018-050ZC 001-597-190-00	1
工事材料 INSTALLATION MATERIALS		CP10-09701 001-538-140-00	1
図書 DOCUMENT			
ヒューズ交換要領 FUSE REPLACEMENT GUIDE		C12-01903-* 000-197-190-1*	1

コード番号末尾の[**]は、選択品の代表コードを表します。
CODE NUMBER ENDING WITH "**" INDICATES THE CODE NUMBER OF REPRESENTATIVE MATERIAL.

(略図の寸法は、参考値です。DIMENSIONS IN DRAWING FOR REFERENCE ONLY.)



C1363-Z01-E

PACKING LIST

10DA-X-9862 -0 1/1

FSV-751-*

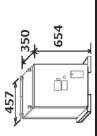
A-5

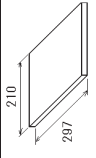
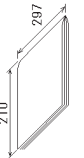
N A M E	O U T L I N E	D E S C R I P T I O N / C O D E N o.	Q ' T Y
ユニット			
送受信装置 TRANSCIVER UNIT		FSV-751-* 000-036-279-00 **	1
予備品			
予備品 SPARE PARTS		SP10-04301 001-538-850-00	1
工事材料			
工事材料 INSTALLATION MATERIALS		CP10-09801 001-538-860-00	1
図書			
取扱説明書 OPERATOR'S MANUAL		OM*-13630-* 000-195-867-1* **	1
整備要領書 INSTALLATION MANUAL		IM*-13630-* 000-195-869-1* **	1

コード番号末尾の[**]印は、選択品の代表コードを表します。
CODE NUMBER ENDING WITH "**" INDICATES THE CODE NUMBER OF REPRESENTATIVE MATERIAL.

(略図の寸法は、参考値です。 DIMENSIONS IN DRAWING FOR REFERENCE ONLY.)



C1363-Z10-A

PACKING LIST

10DA-X-9860 -0 1/1

FSV-7550-180

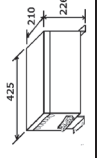
A-6

N A M E	O U T L I N E	D E S C R I P T I O N / C O D E N o.	Q ' T Y
ユニット			
整合箱 MATCHING BOX		FSV-7550-180 000-036-243-00	1
工事材料			
工事材料 INSTALLATION MATERIALS		CP10-10301 001-537-600-00	1

(略図の寸法は、参考値です。 DIMENSIONS IN DRAWING FOR REFERENCE ONLY.)



C1363-Z06-A

PACKING LIST

10DA-X-9861 -0 1/1

FSV-7560

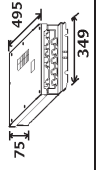
A-7

NAME	OUTLINE	DESCRIPTION/CODE No.	QTY
ユニット			
上下装置延長箱 EXTENSION KIT		FSV-7560 000-036-549-00	1
工事材料			
工事材料 INSTALLATION MATERIALS		CP10-09901 001-546-830-00	1

(略図の寸法は、参考値です。 DIMENSIONS IN DRAWING FOR REFERENCE ONLY.)



C1363-Z07-A

PACKING LIST

10DA-X-9856 -0 1/1

FSV-7504

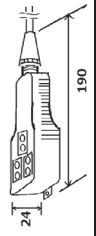
A-8

NAME	OUTLINE	DESCRIPTION/CODE No.	QTY
ユニット			
リモコン REMOTE CONTROLLER		FSV-7504-* 000-036-260-00 **	1
工事材料			
工事材料 INSTALLATION MATERIALS		CP10-04200 006-027-250-00	1

コード番号末尾の[**]は、選択品の代表コードを表します。
CODE NUMBER ENDING WITH "**" INDICATES THE CODE NUMBER OF REPRESENTATIVE MATERIAL

(略図の寸法は、参考値です。 DIMENSIONS IN DRAWING FOR REFERENCE ONLY.)

C1363-Z08-A

CODE NO.	001-541-090-00	100A-X-9421-0	1/1
TYPE	FSV-75-T		

現地組部品
LOCAL ASSEMBLING PARTS

番号 NO.	名称 NAME	略図 OUTLINE	型名/規格 DESCRIPTIONS	数量 QTY	用途/備考 REMARKS
1	O-RING		OO-0117A(P355) CODE NO. 000-158-976-10	1	
2	圧着端子 CRIMP-ON LUG		FV5.5-4(LF) YEL K CODE NO. 000-166-744-11	3	
3	ハセバンド BAND		HP-5N CODE NO. 000-162-508-10	3	
4	ハセ金 SPRING WASHER		M20 SUS304 CODE NO. 000-167-401-10	16	
5	ミナキ丸平座金 FLAT WASHER		M20 SUS304 CODE NO. 000-167-452-10	28	
6	六角ナット 1/2 HEX NUT		M20 SUS304 CODE NO. 000-167-476-10	32	
7	六角ヘッド 全ネジ HEXAGONAL HEAD SCREW		M20X120 SUS304 CODE NO. 000-162-825-10	12	
8	ワッシャーヘッド 全ネジ WASHER HEAD SCREW *B*		M4X12 C2700W MBN12 CODE NO. 000-163-192-10	3	
9	銅板 COPPER STRAP		WEA-1004-O ROHS CODE NO. 500-310-040-10	1	

(略図の寸法は、参考値です。 DIMENSIONS IN DRAWING FOR REFERENCE ONLY.)

FURUNO ELECTRIC CO., LTD.

CODE NO.	001-541-100-00	100A-X-9422-0	1/1
TYPE	FSV-75-N		

現地組部品
LOCAL ASSEMBLING PARTS

番号 NO.	名称 NAME	略図 OUTLINE	型名/規格 DESCRIPTIONS	数量 QTY	用途/備考 REMARKS
1	圧着端子 CRIMP-ON LUG		FV5.5-4(LF) YEL K CODE NO. 000-166-744-11	3	
2	ハセバンド BAND		HP-5N CODE NO. 000-162-508-10	3	
3	ハセ金 SPRING WASHER		M20 SUS304 CODE NO. 000-167-401-10	16	
4	ミナキ丸平座金 FLAT WASHER		M20 SUS304 CODE NO. 000-167-452-10	28	
5	六角ナット 1/2 HEX NUT		M20 SUS304 CODE NO. 000-167-476-10	32	
6	六角ヘッド 全ネジ HEXAGONAL HEAD SCREW		M20X120 SUS304 CODE NO. 000-162-825-10	12	
7	ワッシャーヘッド 全ネジ WASHER HEAD SCREW *B*		M4X12 C2700W MBN12 CODE NO. 000-163-192-10	3	
8	銅板 COPPER STRAP		WEA-1004-O ROHS CODE NO. 500-310-040-10	1	

(略図の寸法は、参考値です。 DIMENSIONS IN DRAWING FOR REFERENCE ONLY.)

FURUNO ELECTRIC CO., LTD.

FURUNO

CODE NO.	001-115-510-00	03HE-X-9407-0	1/1
TYPE	CP03-33202		



工事材料表

INSTALLATION MATERIALS			
番号 NO.	名称 NAME	略図 OUTLINE	数量 QTY
1	KB取付金具 KB FIXTURE	344 	1

FURUNO

CODE NO.	001-537-900-00	100A-X-9401-0	1/1
TYPE	CP10-09601		

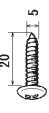
工事材料表

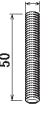
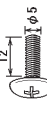
INSTALLATION MATERIALS			
番号 NO.	名称 NAME	略図 OUTLINE	数量 QTY
1	帽子 CAP		4
2	ナット TAPPING SCREW		4
3	冷間圧造鋼ナット WING NUT		4
4	寸切棒 THREADED ROD		4
5	ナット BINDING HEAD SCREW		4

型式/コード番号が2段の場合、下段より上段に代わる通線部品であり、どちらかが入っています。なお、品質は変わりません。

TWO TYPES AND CODES MAY BE LISTED FOR AN ITEM. THE LOWER PRODUCT MAY BE SHIPPED IN PLACE OF THE UPPER PRODUCT. QUALITY IS THE SAME.

(略図の寸法は、参考値です。 DIMENSIONS IN DRAWING FOR REFERENCE ONLY.)

FURUNO ELECTRIC CO., LTD.

C3584-M07-A

(略図の寸法は、参考値です。 DIMENSIONS IN DRAWING FOR REFERENCE ONLY.)

FURUNO ELECTRIC CO., LTD.

C1363-M13-A

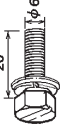

CODE NO.	001-538-140-00	100A-X-9402-0	1/1
TYPE	CP10-09701		

工事材料表			
INSTALLATION MATERIALS			
番号 NO.	名称 NAME	略図 OUTLINE	用途/備考 REMARKS
1	ケーブル CABLE TIE		
		型名/規格 DESCRIPTIONS	数量 Q.TY
		CV-150N	8
		CODE NO. 000-162-166-10	
2	六角スリット HEX HEAD SLOT BOLT-B ワッシャー WASHER		
		M6X20 SUS304	4
		CODE NO. 000-162-348-10	

(略図の寸法は、参考値です。 DIMENSIONS IN DRAWING FOR REFERENCE ONLY.)

FURUNO ELECTRIC CO., LTD.

CODE NO.	006-028-050-00	100I-X-9401-2	1/1
TYPE	CP10-04301		

工事材料表			
INSTALLATION MATERIALS			
番号 NO.	名称 NAME	略図 OUTLINE	用途/備考 REMARKS
1	ケーブル INSULATION TUBE(A)		
		型名/規格 DESCRIPTIONS	数量 Q.TY
		4.0X0.3 #10 5CM	1
		CODE NO. 000-100-923-00	
2	コネクタ CONNECTOR(NCS)		
		NCS-253-P "ROHS"	
		NCS-253-P	1
		CODE NO. 000-160-153-10	
		000-506-503-10	

型式/コード番号が2段の場合、下段より上段に代わる過渡期品であり、どちらかが入っています。 なお、品質は変わりません。



TWO TYPES AND CODES MAY BE LISTED FOR AN ITEM. THE LOWER PRODUCT MAY BE SHIPPED IN PLACE OF THE UPPER PRODUCT. QUALITY IS THE SAME.

(略図の寸法は、参考値です。 DIMENSIONS IN DRAWING FOR REFERENCE ONLY.)

CODE NO.	001-538-860-00	100A-X-9403 -0	1/1
TYPE	CP10-09801		

工事材料表

INSTALLATION MATERIALS

番号 NO.	名称 NAME	略図 OUTLINE	型名/規格 DESCRIPTIONS	数量 Q'TY	用途/備考 REMARKS
1	圧着端子 CRIMP-ON LUG		FV2-4 BLU K CODE NO. 000-157-247-11	2	
2	7→銅板 COPPER STRAP		MEA-1004-O ROHS CODE NO. 500-310-040-10	1	

(略図の寸法は、参考値です。 DIMENSIONS IN DRAWING FOR REFERENCE ONLY.)

FURUNO ELECTRIC CO . . . LTD.

CODE NO.	001-537-600-00	100A-X-9411 -0	1/1
TYPE	CP10-10301		

工事材料表



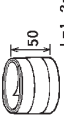



INSTALLATION MATERIALS

番号 NO.	名称 NAME	略図 OUTLINE	型名/規格 DESCRIPTIONS	数量 Q'TY	用途/備考 REMARKS
1	六角穴円形 ねじ HEX HEAD SLOT BOLT-B WASHER		M10X25 SUS304 CODE NO. 000-162-925-10	4	
2	7→銅板 COPPER STRAP		MEA-1004-O ROHS CODE NO. 500-310-040-10	1	

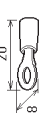
(略図の寸法は、参考値です。 DIMENSIONS IN DRAWING FOR REFERENCE ONLY.)

FURUNO ELECTRIC CO . . . LTD.

CODE NO.	001-546-830-00	100A-X-9409-0
TYPE	CP10-09901	1/1

工事材料表		INSTALLATION MATERIALS		略図 OUTLINE	型名/規格 DESCRIPTIONS	数量 Q'TY	用途/備考 REMARKS
番号 NO.	名称 NAME						
1	ケーブルタイ CABLE TIE				CV-150N CODE NO. 000-162-166-10	20	
2	圧着端子 CRIMP-ON LUG				FV1.25-4(LF) RED K CODE NO. 000-166-666-11	8	
3	圧着端子 CRIMP-ON LUG				FV5.5-4(LF) YEL K CODE NO. 000-166-744-11	6	
4	扁平座金 FLAT WASHER				M10 SUS304 CODE NO. 000-167-232-10	4	
5	六角ナット 1/2 HEX. NUT				M10 SUS304 CODE NO. 000-166-775-10	4	
6	バネ座金 SPRING WASHER				M10 SUS304 CODE NO. 000-167-233-10	4	
7	銅板 COPPER STRAP				WEA-1004-0 ROHS CODE NO. 500-310-040-10	1	

(略図の寸法は、参考値です。 DIMENSIONS IN DRAWING FOR REFERENCE ONLY.)

FURUNO ELECTRIC CO., LTD.

CODE NO.	006-027-250-00	10CH-X-9405-3
TYPE	CP10-04200	1/1

工事材料表		INSTALLATION MATERIALS		略図 OUTLINE	型名/規格 DESCRIPTIONS	数量 Q'TY	用途/備考 REMARKS
番号 NO.	名称 NAME						
1	TF型玉付きフック HOOK	CSH-7040/CH-256			TF-20 TF-20 CODE NO. 000-167-860-10 000-305-859-30	1	

型式/ナド'番号が2取の場合、下取より上取に代わる標準品であり、どちらが入っています。 なお、品質は変わりませ
ん。 TWO TYPES AND CODES MAY BE LISTED FOR AN ITEM. THE LOWER PRODUCT MAY BE SHIPPED IN PLACE OF THE UPPER
PRODUCT. QUALITY IS THE SAME.
(略図の寸法は、参考値です。 DIMENSIONS IN DRAWING FOR REFERENCE ONLY.)

FURUNO ELECTRIC CO., LTD.

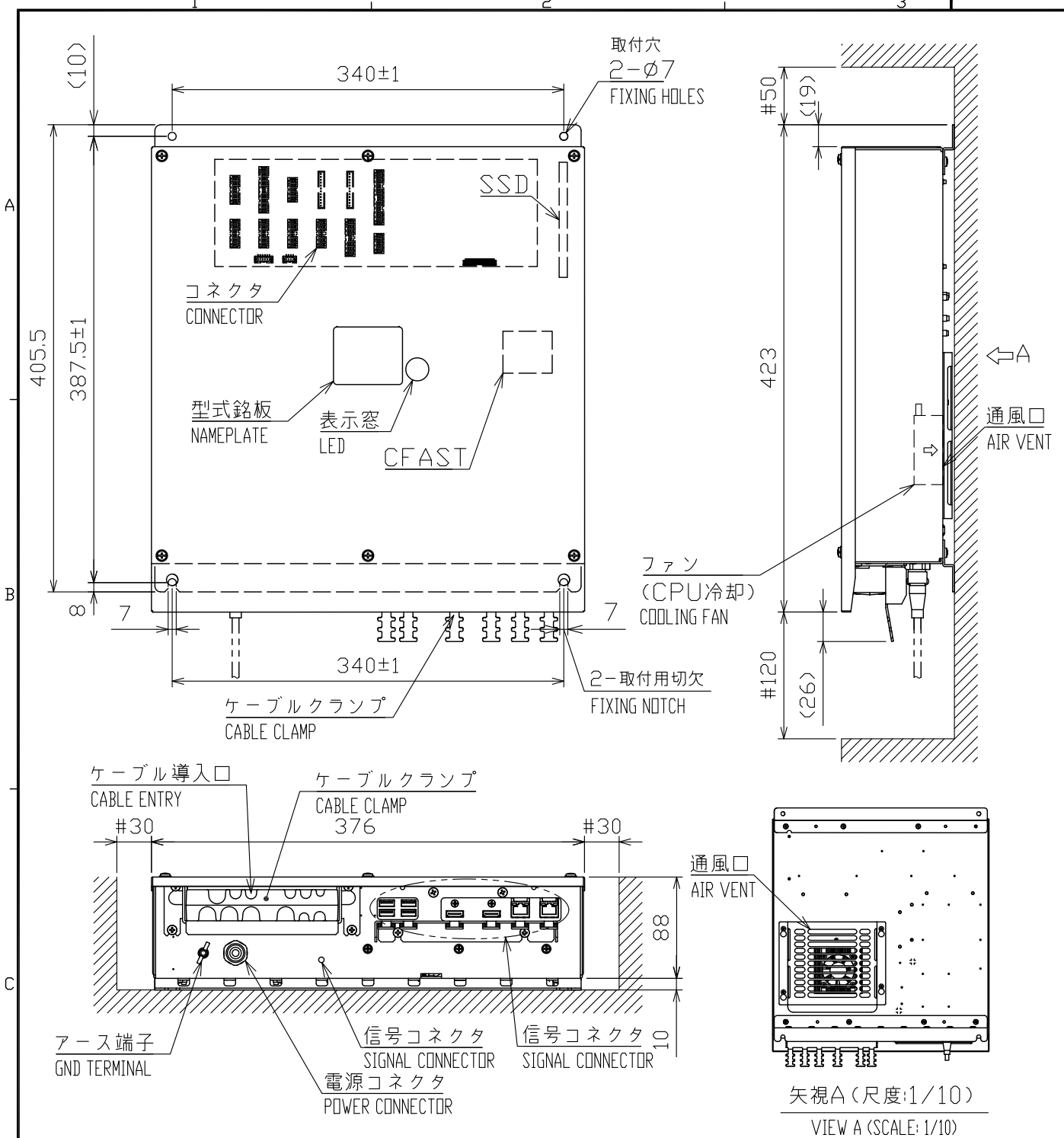

注記

- 1) 指定外の寸法公差は表1による。
- 2) #印寸法は最小サービス空間寸法とする。
- 3) 取付用ネジはM6ボルト、またはコーチボルト呼び径6を使用。

NOTE

1. TABLE 1 INDICATES TOLERANCE OF DIMENSIONS WHICH IS NOT SPECIFIED.
2. #: MINIMUM SERVICE CLEARANCE.
3. USE M6 BOLTS OR COARCH SCREWS FOR FIXING THE UNIT.

表1 TABLE 1

寸法区分 (mm) DIMENSION	公差 (mm) TOLERANCE
$L \leq 50$	± 1.5
$50 < L \leq 100$	± 2.5
$100 < L \leq 500$	± 3

DRAWN	6/Mar/2019 T.YAMASAKI	TITLE	FSV-7503
CHECKED	6/Mar/2019 H.MAKI	名称	制御部 (壁掛・床置装備)
APPROVED	6/Mar/2019 H.MAKI	外寸図	
SCALE	1/5	MASS	7.6 $\pm 10\%$ kg
DWG. No.	C1363-G01-B	REF. No.	10-090-350G-2
		NAME	PROCESSOR UNIT (BULKHEAD/FLOOR MOUNT)
			OUTLINE DRAWING

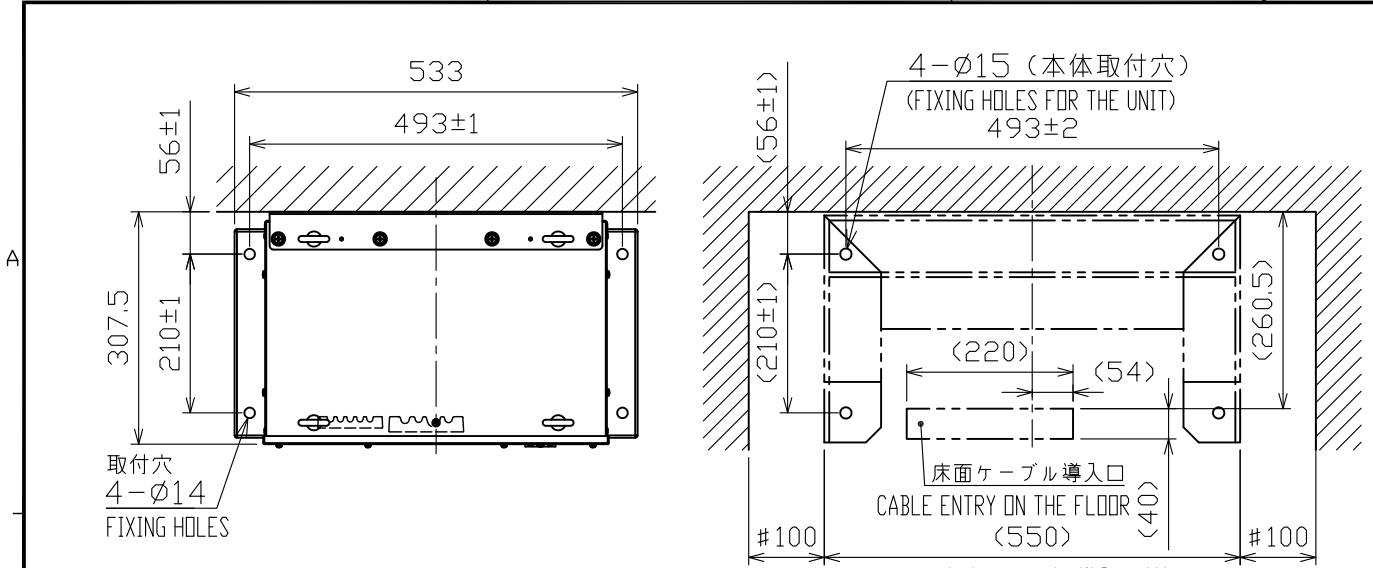

架台・ケーブル導入口寸法
DIMENSIONS FOR MOUNTING BASE AND CABLE ENTRY

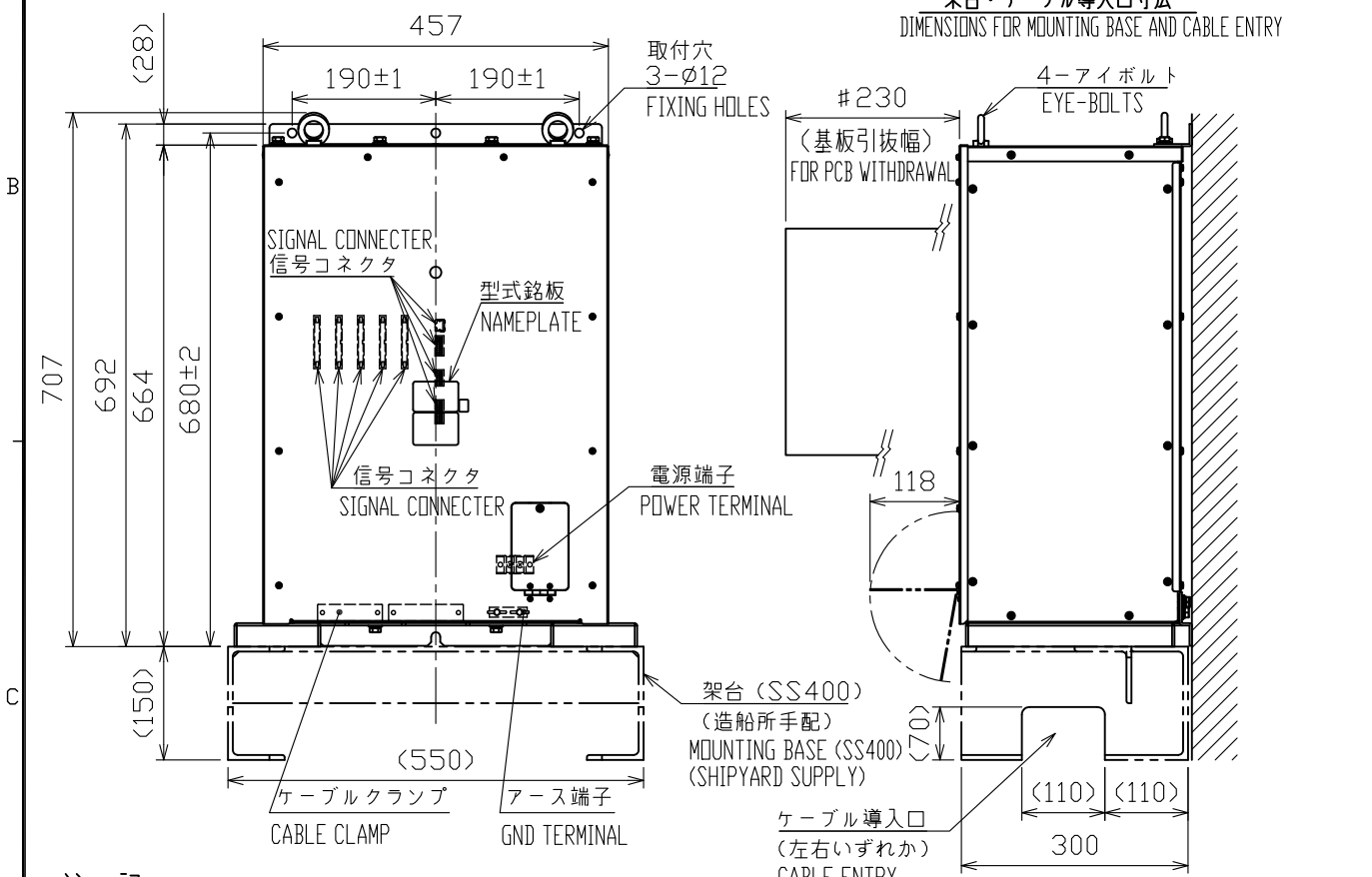

- 注記
- 1) 指定外の寸法公差は表1による。
 - 2) #印寸法は最小サービス空間寸法とする。
 - 3) 取付用ネジはM10およびM12ボルト (SUS304) を使用のこと。
 - 4) 架台高さは150以上、ケーブル導入口は参考寸法とする。

表1 TABLE 1

寸法区分 (mm) DIMENSION	公差 (mm) TOLERANCE
L ≤ 50	±1.5
50 < L ≤ 100	±2.5
100 < L ≤ 500	±3
500 < L ≤ 1000	±4

- NOTE
1. TABLE 1 INDICATES TOLERANCE OF DIMENSIONS WHICH IS NOT SPECIFIED.
 2. #: MINIMUM SERVICE CLEARANCE.
 3. USE M10 AND M12 BOLTS (SUS304) FOR FIXING THE UNIT.
 4. MOUNTING BASE HEIGHT: 150 OR MORE. CABLE ENTRY DIMENSIONS ARE REFERENCE.

DRAWN	22/Nov/2018 T.YAMASAKI	TITLE	F5V-751
CHECKED	22/Nov/2018 H.MAKI	名称	送受信装置 (床置装備)
APPROVED	22/Aug/2018 H.MAKI	F5V-75	外寸図
SCALE	1/10 MASS 55 ±10% kg	NAME	TRANSCEIVER UNIT (FLOOR MOUNT)
DWG. No.	C1363-G02-B	REF. No.	10-090-650G-2
		OUTLINE DRAWING	



表1 TABLE 1

寸法区分 (mm) DIMENSION	公差 (mm) TOLERANCE
L ≤ 50	±1.5
50 < L ≤ 100	±2.5
100 < L ≤ 500	±3
500 < L ≤ 1000	±4

注 記

- 1) 指定外の寸法公差は表1による。
- 2) #印寸法は最小サービス空間寸法とする。
- 3) 取付用ネジはM10ボルト又はコーチボルト呼び10を使用のこと。

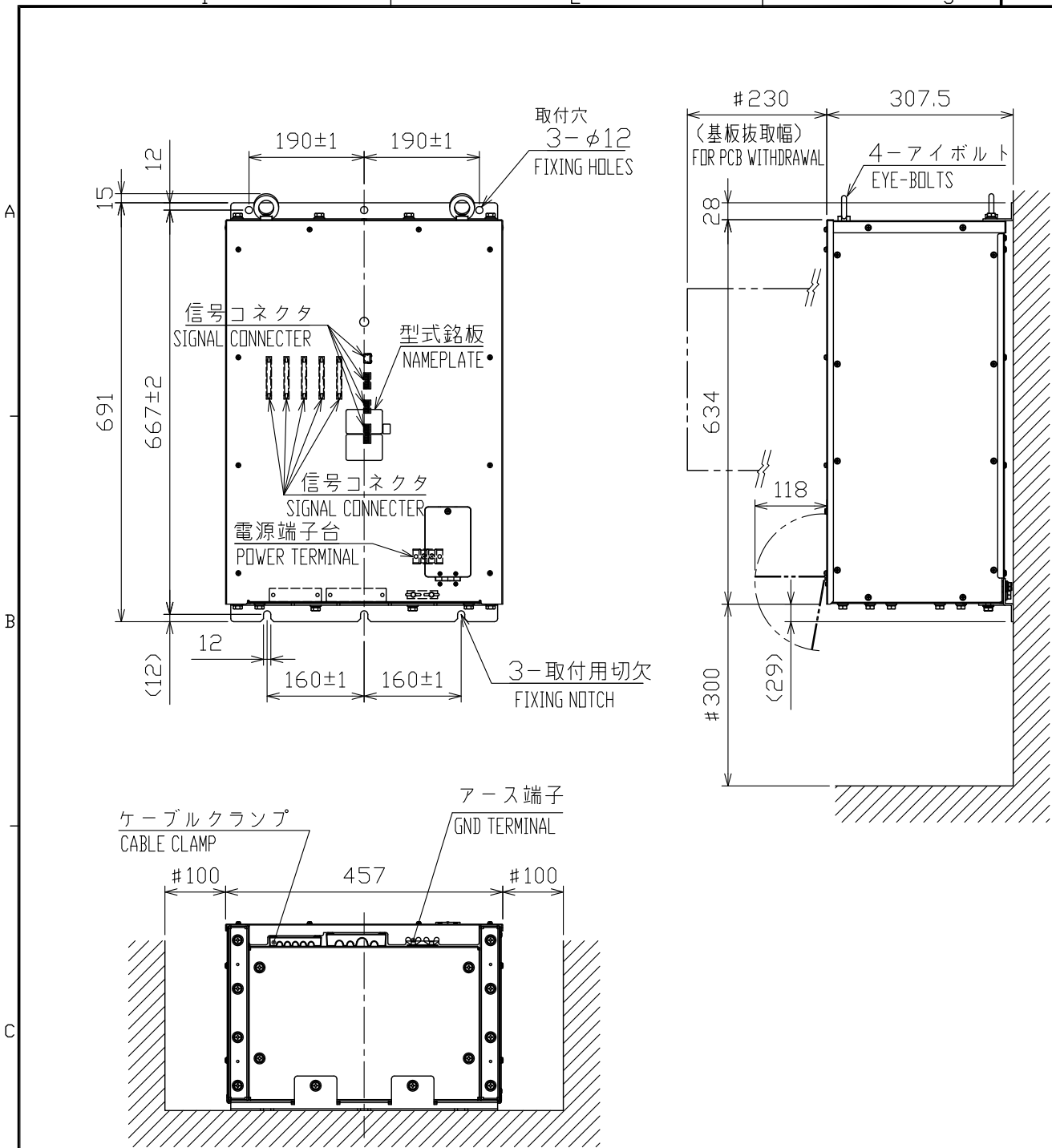
NOTE

1. TABLE 1 INDICATES TOLERANCE OF DIMENSIONS WHICH IS NOT SPECIFIED.
2. #: MINIMUM SERVICE CLEARANCE.
3. USE M10 BOLTS OR COACH SCREWS φ10 FOR FIXING THE UNIT.

DRAWN 20/Aug/2018 T.YAMASAKI		TITLE FSV-751
CHECKED 20/Aug/2018 H.MAKI		名称 送受信装置 (壁掛装備)
APPROVED 22/Aug/2018 H.MAKI	FSV-75	外寸図
SCALE 1/10	MASS 51 ±10% kg	NAME TRANSCEIVER UNIT (BULKHEAD MOUNT)
DWG. No. C1363-G03-A	REF. No. 10-090-651G-1	OUTLINE DRAWING

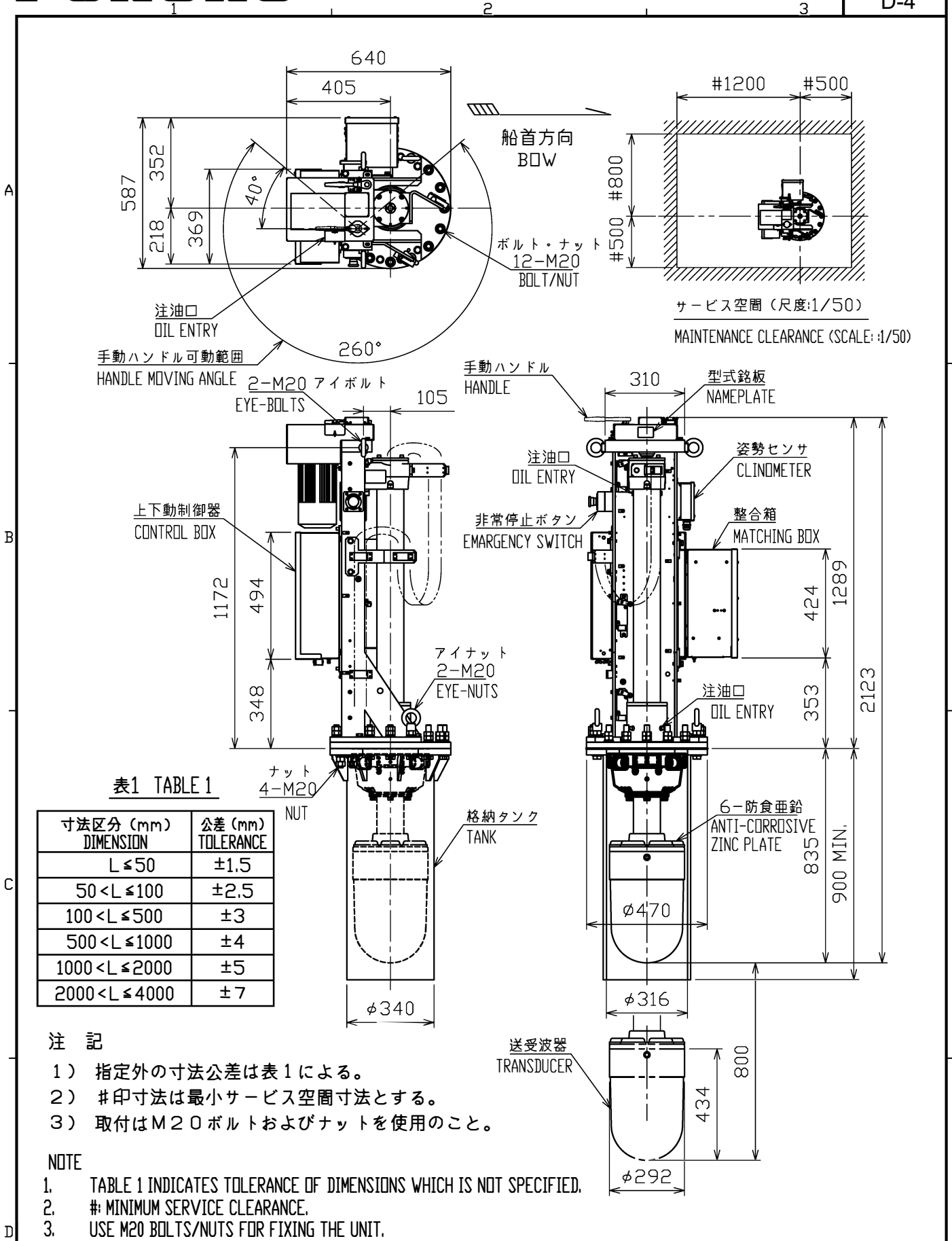

DRAWN 24/Nov/2020 T.YAMASAKI		TITLE FSV-753
CHECKED 24/Nov/2020 H.MAKI		名称 上下装置 (800ストローク)
APPROVED 17/Feb/2021 H.MAKI	FSV-75	外寸図
SCALE 1/20	MASS 340 ±10% kg	質量は格納タンクを含まず。 MASS DOES NOT INCLUDE TANK.
DWG. No. C1363-G04-C	REF. No. 10-090-551G-4	NAME HULL UNIT (800 TRAVEL)
		OUTLINE DRAWING

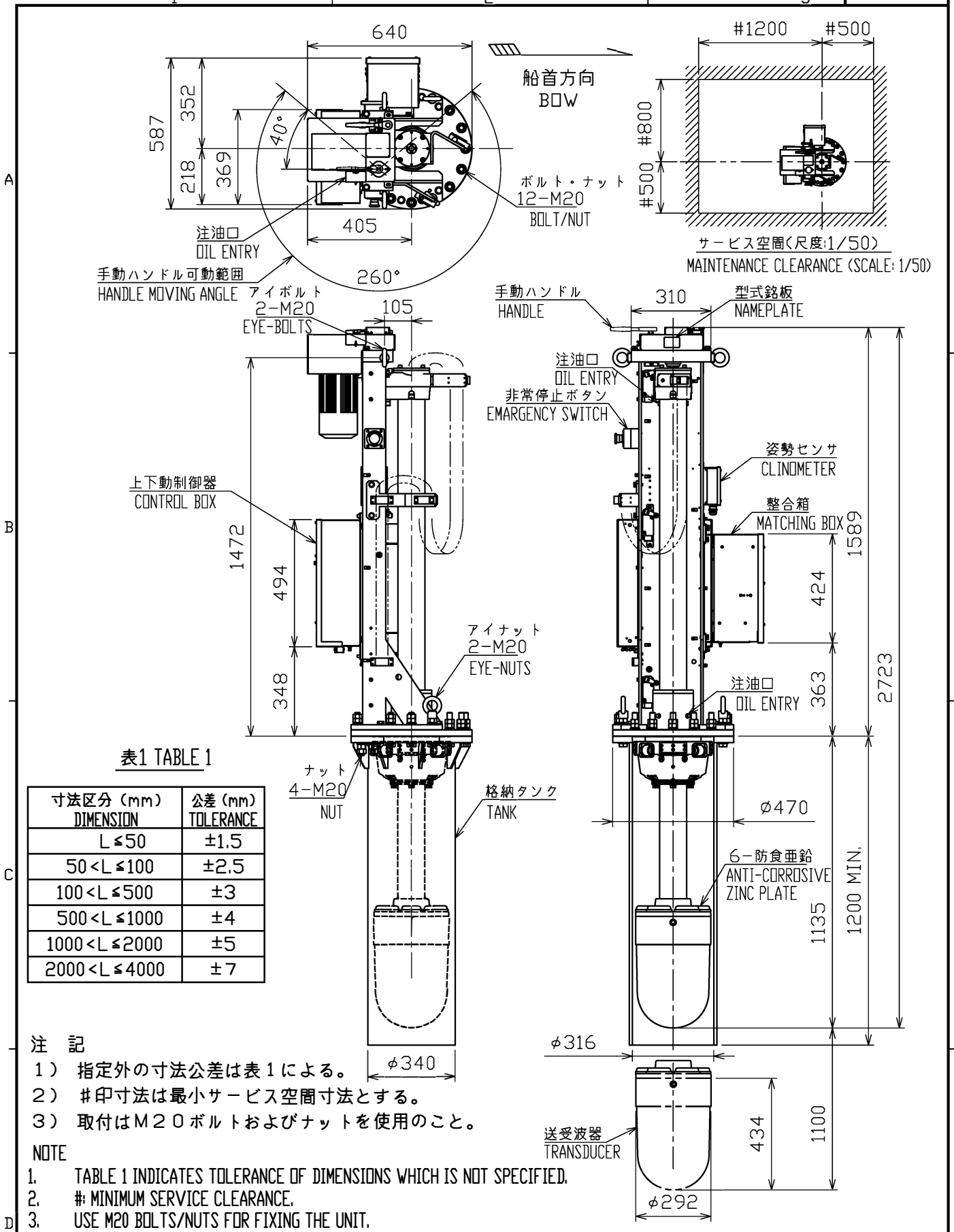

DRAWN 24/Nov/2020 T.YAMASAKI		TITLE FSV-754
CHECKED 24/Nov/2020 H.MAKI		名称 上下装置 (1100ストローク)
APPROVED 17/Feb/2021 H.MAKI	FSV-75	外寸図
SCALE 1/20	MASS 360 ±10% kg	質量は格納タンクを含まず。 MASS DOES NOT INCLUDE TANK.
DWG. No. C1363-G05-C	REF. No. 10-090-552G-4	NAME HULL UNIT (1100 TRAVEL)
		OUTLINE DRAWING



表 1 TABLE 1

寸法区分 (mm) DIMENSION	公差 (mm) TOLERANCE
L ≤ 50	±1.5
50 < L ≤ 100	±2.5
100 < L ≤ 500	±3

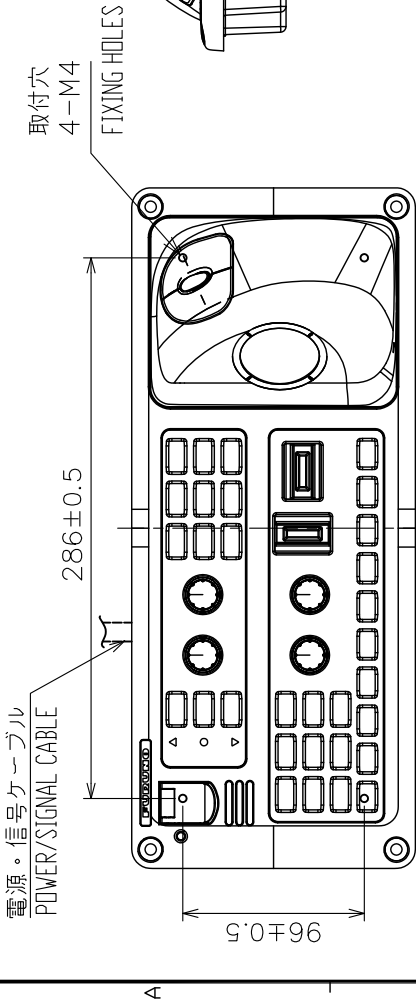

表 2 TABLE 2

ケーブル長(m) CABLE LENGTH	質量 (kg±10%) MASS
5	1.8
10	2.4

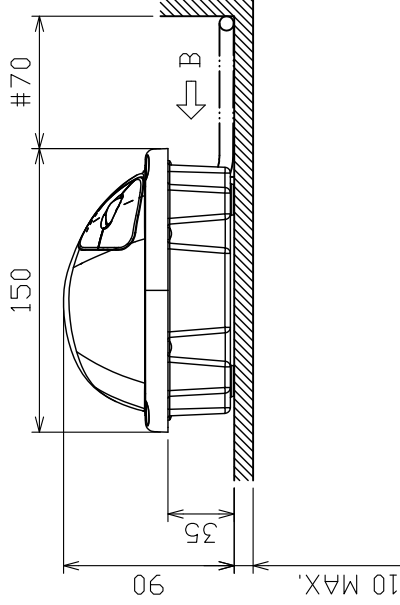
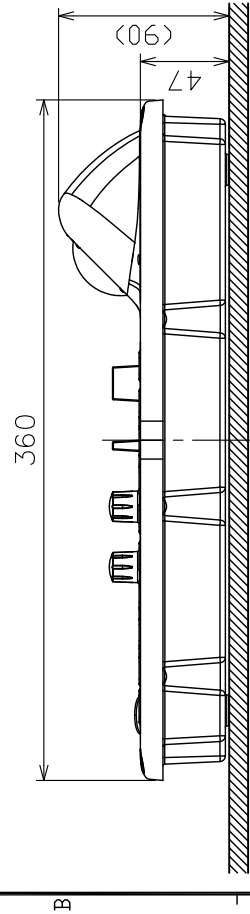
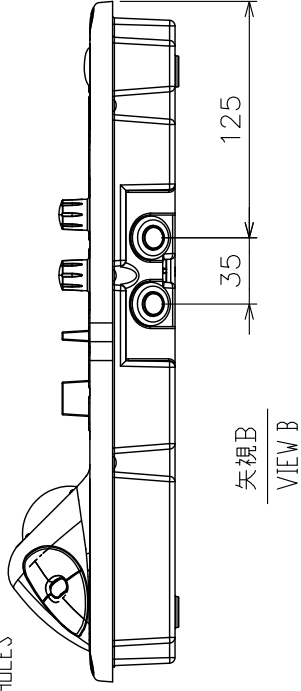
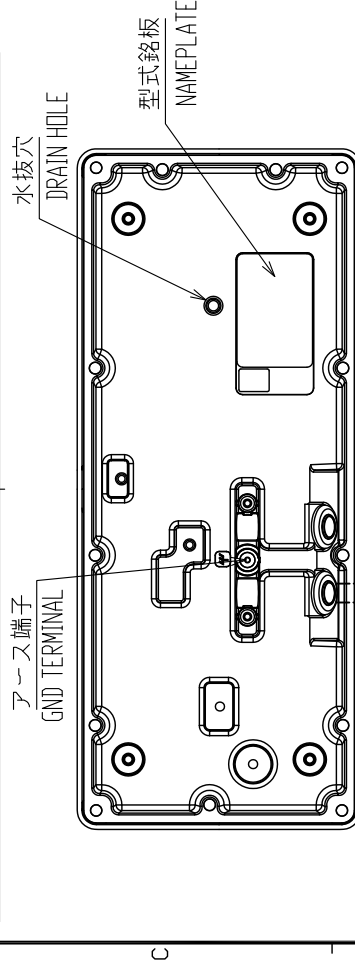

注 記

- 1) 指定外の寸法公差は表1による。
- 2) #印寸法は最小サービス空間寸法とする。
- 3) 取付ネジは寸切りボルトM4×50と蝶ナットを使用のこと。

NOTE

1. TABLE 1 INDICATES TOLERANCE OF DIMENSIONS WHICH IS NOT SPECIFIED.
2. # MINIMUM SERVICE CLEARANCE.
3. USE M4 STUD-BOLT AND WING NUT FOR FIXING THE UNIT.

DRAWN	15/Apr/2019	T.YAMASAKI	TITLE	FSV-7501
CHECKED	15/Apr/2019	H.MAKI	名称	操作部 (卓上装備)
APPROVED	16/Apr/2019	H.MAKI	外寸図	FSV-75
SCALE	1/4	MASS 表2参照 TABLE 2	NAME	CONTROL UNIT (TABLETOP MOUNT)
IMGNo.	C1363-606-C	REF.No.	10-090-200G-3	OUTLINE DRAWING

表1 TABLE 1

寸法区分 (mm) DIMENSION	公差 (mm) TOLERANCE
L ≤ 50	±1.5
50 < L ≤ 100	±2.5
100 < L ≤ 500	±3

表2 TABLE 2

ケーブル長(m) CABLE LENGTH/MASS	質量 (kg±10%)
5	1.8
10	2.4

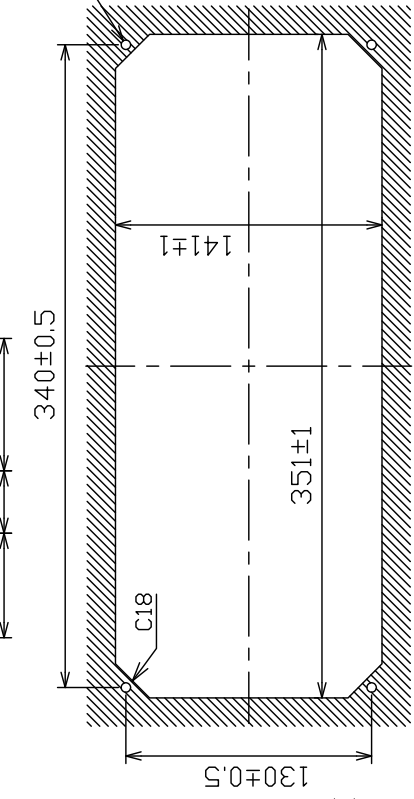
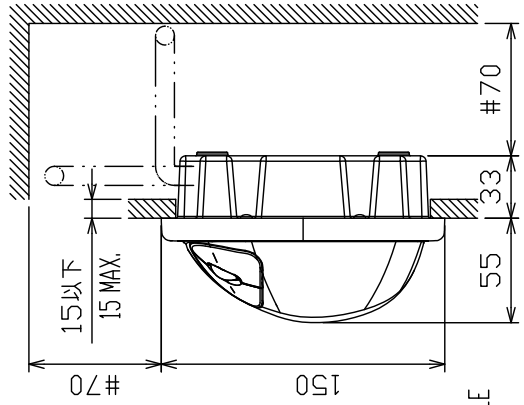
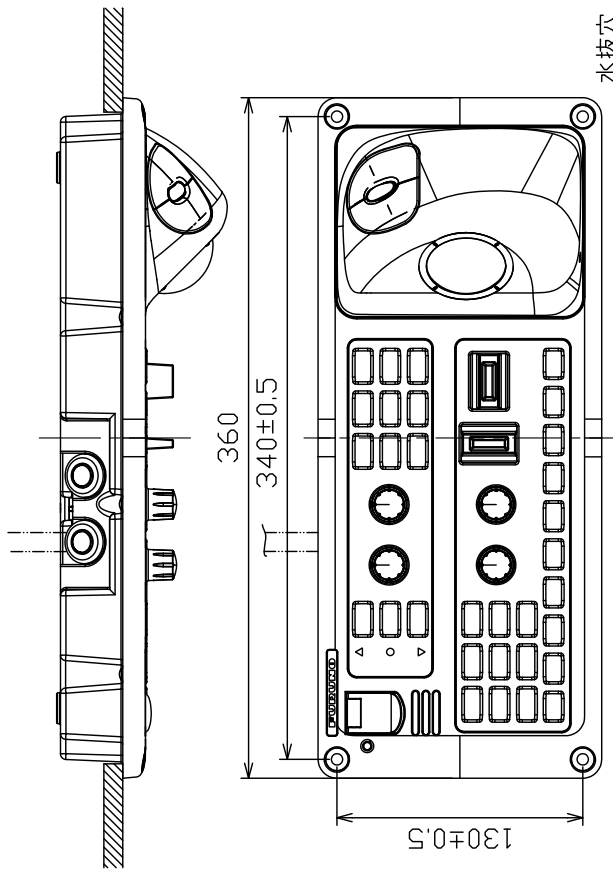

取付寸法 (参考)
CUTOUT DIMENSIONS (REFERENCE)

- 注記
- 指定外の寸法公差は表1による。
 - #印寸法は最小サービス空間寸法とする。
 - 取付ネジはトラスナジ呼び径5×20を使用のこと。
- NOTE
- TABLE 1 INDICATES TOLERANCE OF DIMENSIONS WHICH IS NOT SPECIFIED.
 - #: MINIMUM SERVICE CLEARANCE.
 - USE TAPPING SCREWS $\phi 5 \times 20$ FOR FIXING THE UNIT.

DRAWN	15/Apr/2019	T.YAMASAKI	TITLE	FSV-7501
CHECKED	15/Apr/2019	H.IMAKI	名称	操作部 (埋込装備)
APPROVED	16/Apr/2019	H.MAKI	外寸図	
SCALE	1/4	MASS 表2参照 TABLE 2	NAME	CONTROL UNIT (FLUSH MOUNT)
DWG.No.	C1363-607-C	REF.No.	10-090-210G-3	OUTLINE DRAWING

表1 TABLE 1

寸法区分 (mm) DIMENSION	公差 (mm) TOLERANCE
L ≤ 50	±1.5
50 < L ≤ 100	±2.5
100 < L ≤ 500	±3

取付穴
2-φ5.5
FIXING HOLES

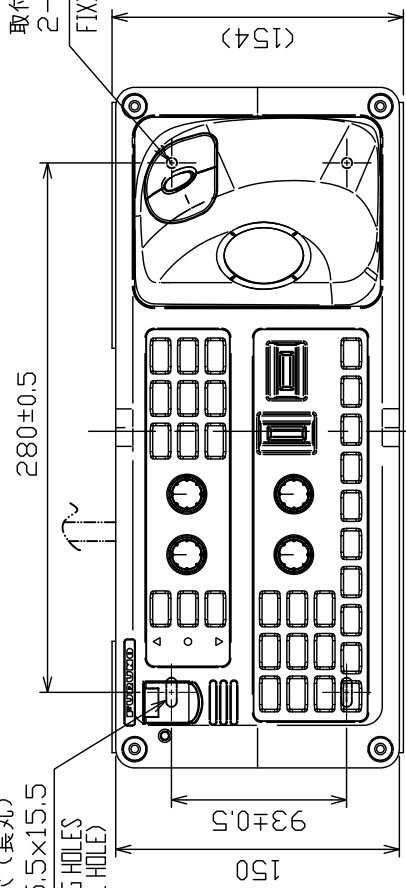

矢視 A
VIEW A

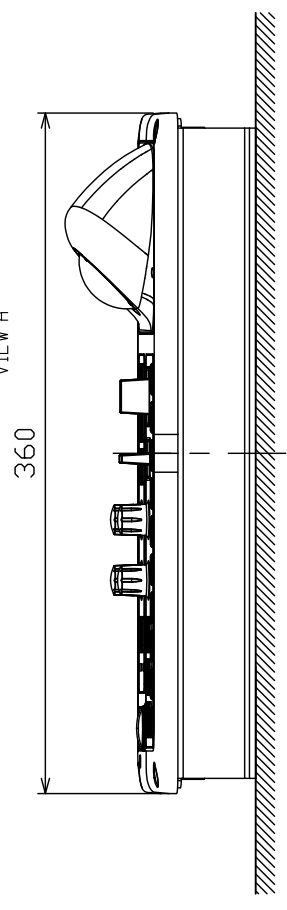

矢視 B
VIEW B



表2 TABLE 2

ケーブル長(m) CABLE LENGTH	質量 (kg±10%) MASS
5	2.9
10	3.5

NOTE
 1. TABLE 1 INDICATES TOLERANCE OF DIMENSIONS WHICH IS NOT SPECIFIED.
 2. #: MINIMUM SERVICE CLEARANCE.
 3. USE TAPPING SCREWS φ5x20 FOR FIXING THE UNIT.

注記

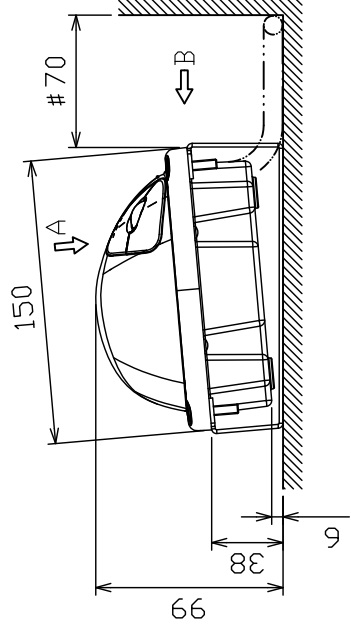
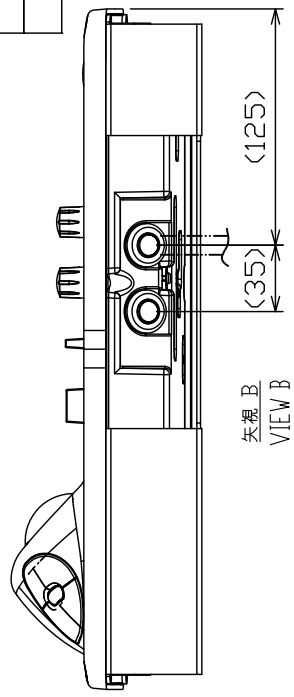
- 1) 指定外の寸法公差は表1による。
- 2) #印寸法は最小サービス空間寸法とする。
- 3) 取付ネジはトラスタッピネジ呼び径5×20を使用のこと。

水抜穴
DRAIN HOLE

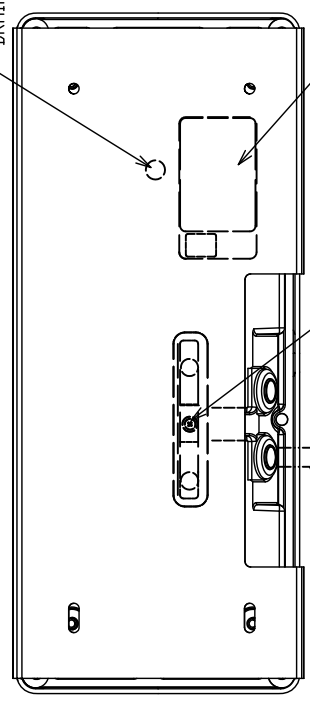

電源・信号ケーブル
POWER/SIGNAL CABLE

アース端子
GND TERMINAL

型式銘板
NAMEPLATE

DRAWN	15/Apr/2019	I.YAMASAKI	TITLE	FSV-7501
CHECKED	15/Apr/2019	H.MAKI	名称	操作部 (取付金具)
APPROVED	16/Apr/2019	H.MAKI	外寸図	FSV-75
SCALE	1/4	MASS 表2参照 TABLE 2	NAME	CONTROL UNIT (FIXTURE MOUNT)
IMGNo.	C1363-G08-C	REF.No.	10-090-220G-3	OUTLINE DRAWING

表1 TABLE 1

寸法区分 (mm) DIMENSION	公差 (mm) TOLERANCE
$L \leq 50$	± 1.5
$50 < L \leq 100$	± 2.5
$100 < L \leq 500$	± 3

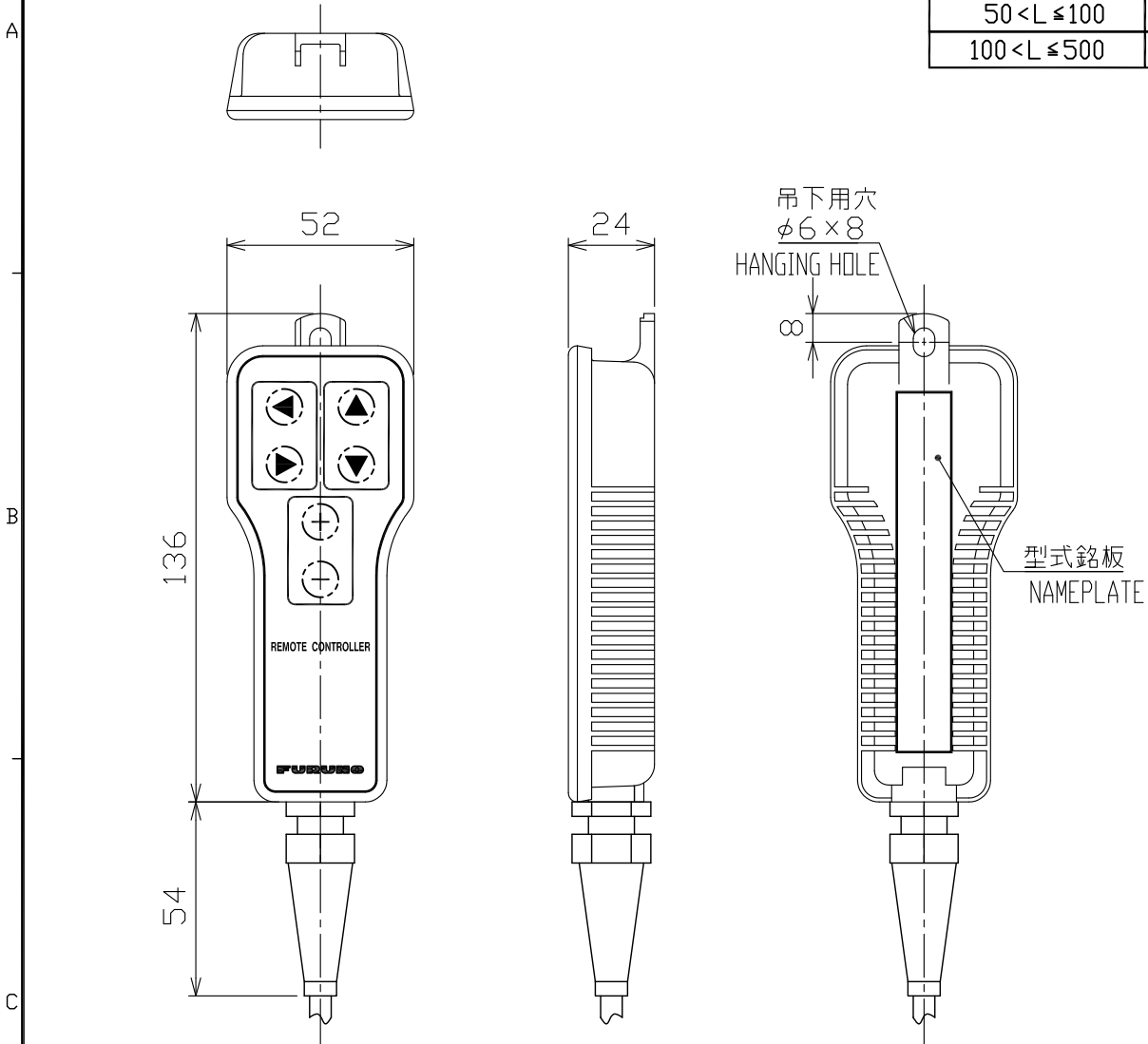

注 記

1) 指定外の寸法公差は表 1 による。

NOTE

1. TABLE 1 INDICATES TOLERANCE OF DIMENSIONS WHICH IS NOT SPECIFIED.

表2 TABLE 2

ケーブル長 (m) CABLE LENGTH	質量 (kg $\pm 10\%$) MASS
5	0.46
10	0.76

DRAWN 15/Apr/2019 T.YAMASAKI		TITLE FSV-7504
CHECKED 15/Apr/2019 H.MAKI		名称 リモコン
APPROVED 16/Apr/2019 H.MAKI	FSV-75	外寸図
SCALE 1/2	MASS 表2参照 TABLE 2	NAME REMOTE CONTROLLER
DWG. No. C1363-G09- B	REF. No. 10-090-260G- 2	OUTLINE DRAWING

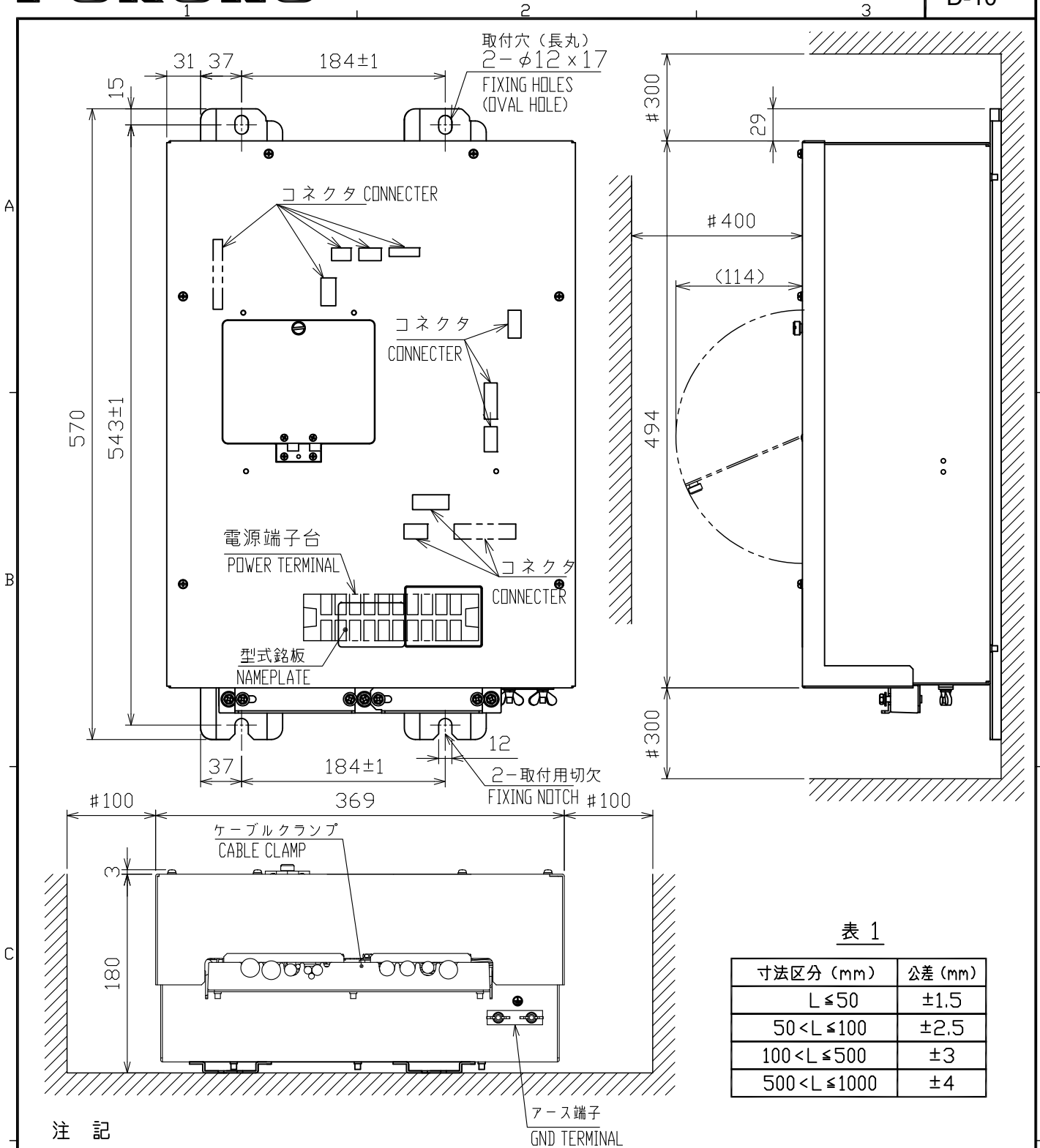

注 記

- 1) 指定外の寸法公差は表 1 による。
- 2) #印寸法は最小サービス空間寸法とする。
- 3) 取付は M 1 0 ボルトを使用のこと。

NOTE

1. TABLE 1 INDICATES TOLERANCE OF DIMENSIONS WHICH IS NOT SPECIFIED.
2. #: MINIMUM SERVICE CLEARANCE.
3. USE M10 BOLTS FOR FIXING THE UNIT.

DRAWN	5/Oct/2018 T. YAMASAKI	TITLE	FSV-7530
CHECKED	5/Oct/2018 H. MAKI	名称	上下装置制御器 (壁掛装備)
APPROVED	9/Oct/2018 H. MAKI	型式	FSV-75
SCALE	1/5	質量	18 ±10% kg
DWG. No.	C1363-G10-A	REF. No.	10-090-580G-1
		NAME	CONTROL BOX (BULKHEAD MOUNT)
			OUTLINE DRAWING

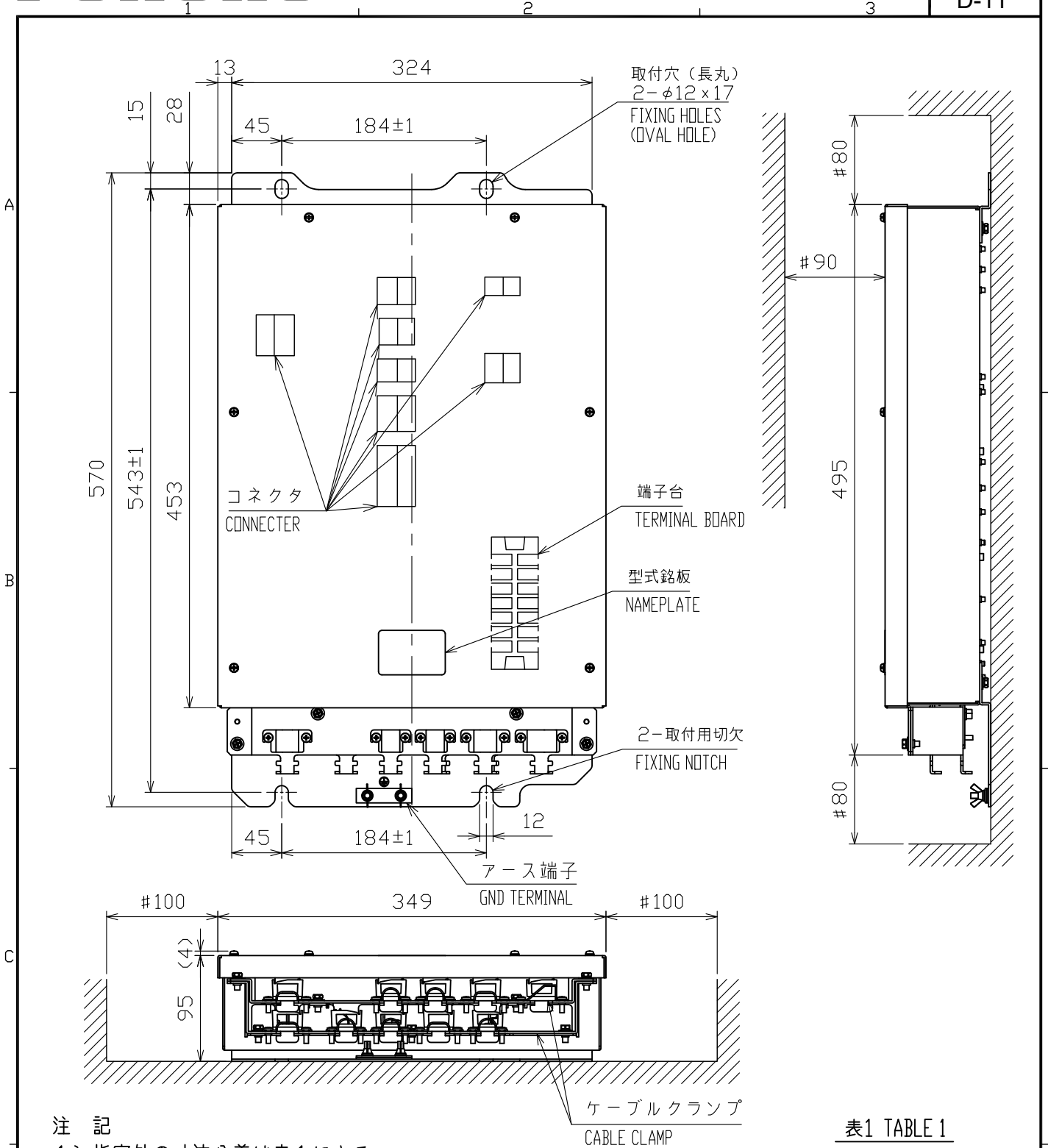

注 記

- 1) 指定外の寸法公差は表 1 による。
- 2) # 印寸法は最小サービス空間寸法とする。
- 3) 取付は M 1 0 ボルトを使用のこと。

NOTE

1. TABLE 1 INDICATES TOLERANCE OF DIMENSIONS WHICH IS NOT SPECIFIED.
2. #: MINIMUM SERVICE CLEARANCE.
3. USE M10 BOLTS FOR FIXING THE UNIT.

表1 TABLE 1

寸法区分 (mm) DIMENSION	公差 (mm) TOLERANCE
$L \leq 50$	±1.5
$50 < L \leq 100$	±2.5
$100 < L \leq 500$	±3
$500 < L \leq 1000$	±4

DRAWN 19/Apr/2019 T. YAMASAKI	TITLE FSV-7560
CHECKED 19/Apr/2019 H. MAKI	名称 上下装置延長箱 (壁掛装備)
APPROVED 22/Apr/2019 H. MAKI	外寸図
SCALE 1/5 MASS 10 ±10% kg	NAME EXTENSION BOX (BULKHEAD MOUNT)
DWG. No. C1363-G11- B	REF. No. 10-090-585G-4
OUTLINE DRAWING	



表1 TABLE 1

寸法区分 (mm) DIMENSION	公差 (mm) TOLERANCE
$L \leq 50$	± 1.5
$50 < L \leq 100$	± 2.5
$100 < L \leq 500$	± 3
$500 < L \leq 1000$	± 4

注 記

- 1) 指定外の寸法公差は表 1 による。
- 2) #印寸法は最小サービス空間寸法とする。
- 3) 取付は M 1 0 ボルトを使用のこと。

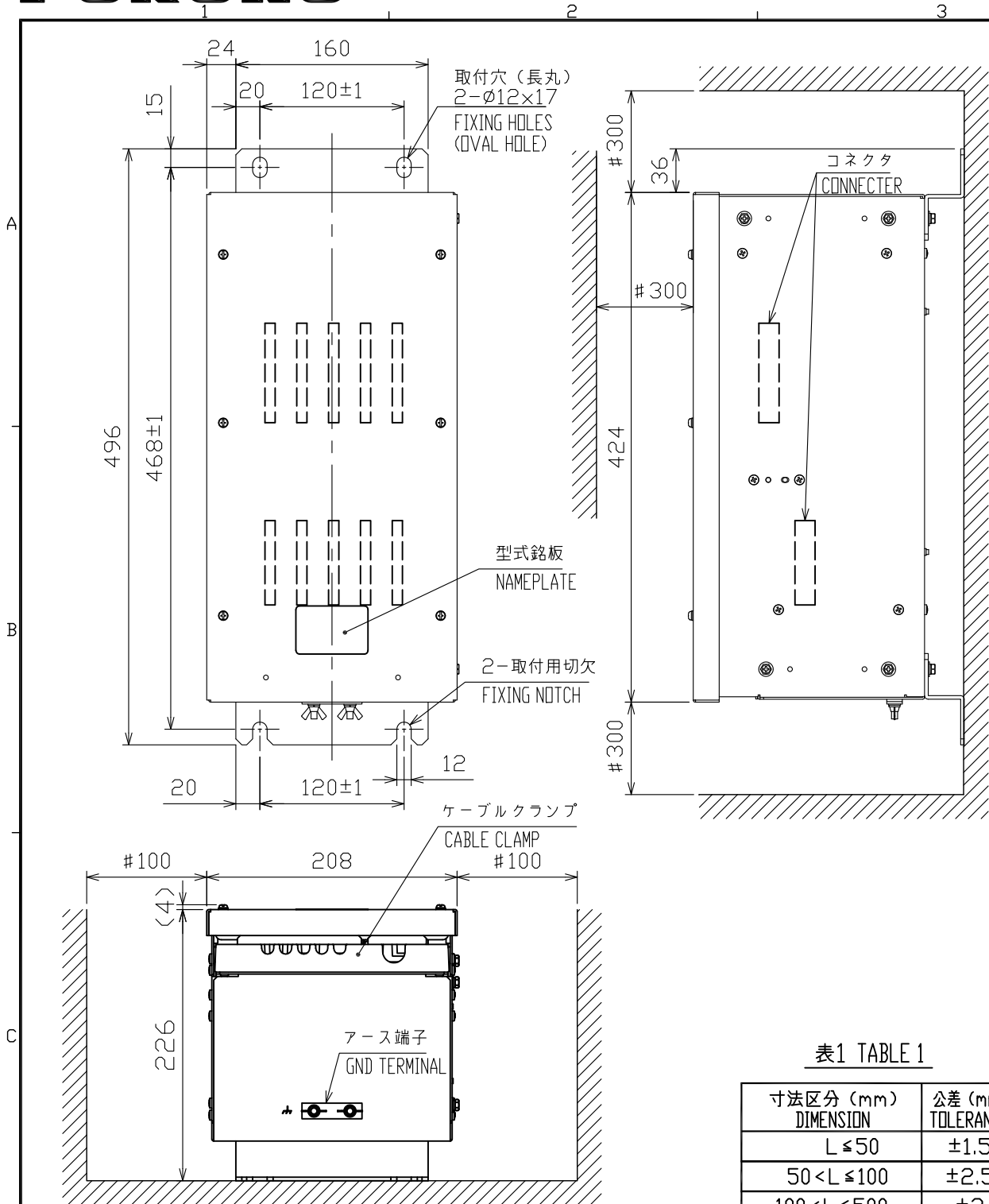
NOTE

1. TABLE 1 INDICATES TOLERANCE OF DIMENSIONS WHICH IS NOT SPECIFIED.
2. #: MINIMUM SERVICE CLEARANCE.
3. USE M10 BOLTS FOR FIXING THE UNIT.

DRAWN	9/Oct/2018 T. YAMASAKI	TITLE	FSV-7550
CHECKED	9/Oct/2018 H. MAKI	名称	整合箱 (壁掛装備)
APPROVED	9/Oct/2018 H. MAKI	FSV-75	外寸図
SCALE	1/5	MASS	10 $\pm 10\%$ kg
DWG. No.	C1363-G12-A	REF. No.	10-090-750G-3
		NAME	MATCHING BOX (BULKHEAD MOUNT)
			OUTLINE DRAWING



表1 TABLE 1

寸法区分 (mm) DIMENSION	公差 (mm) TOLERANCE
$L \leq 50$	± 1.5
$50 < L \leq 100$	± 2.5
$100 < L \leq 500$	± 3
$500 < L \leq 1000$	± 4

注 記

- 1) 指定外の寸法公差は表 1 による。
- 2) # 印寸法は最小サービス空間寸法とする。
- 3) 取付は M 1 0 ボルトを使用のこと。

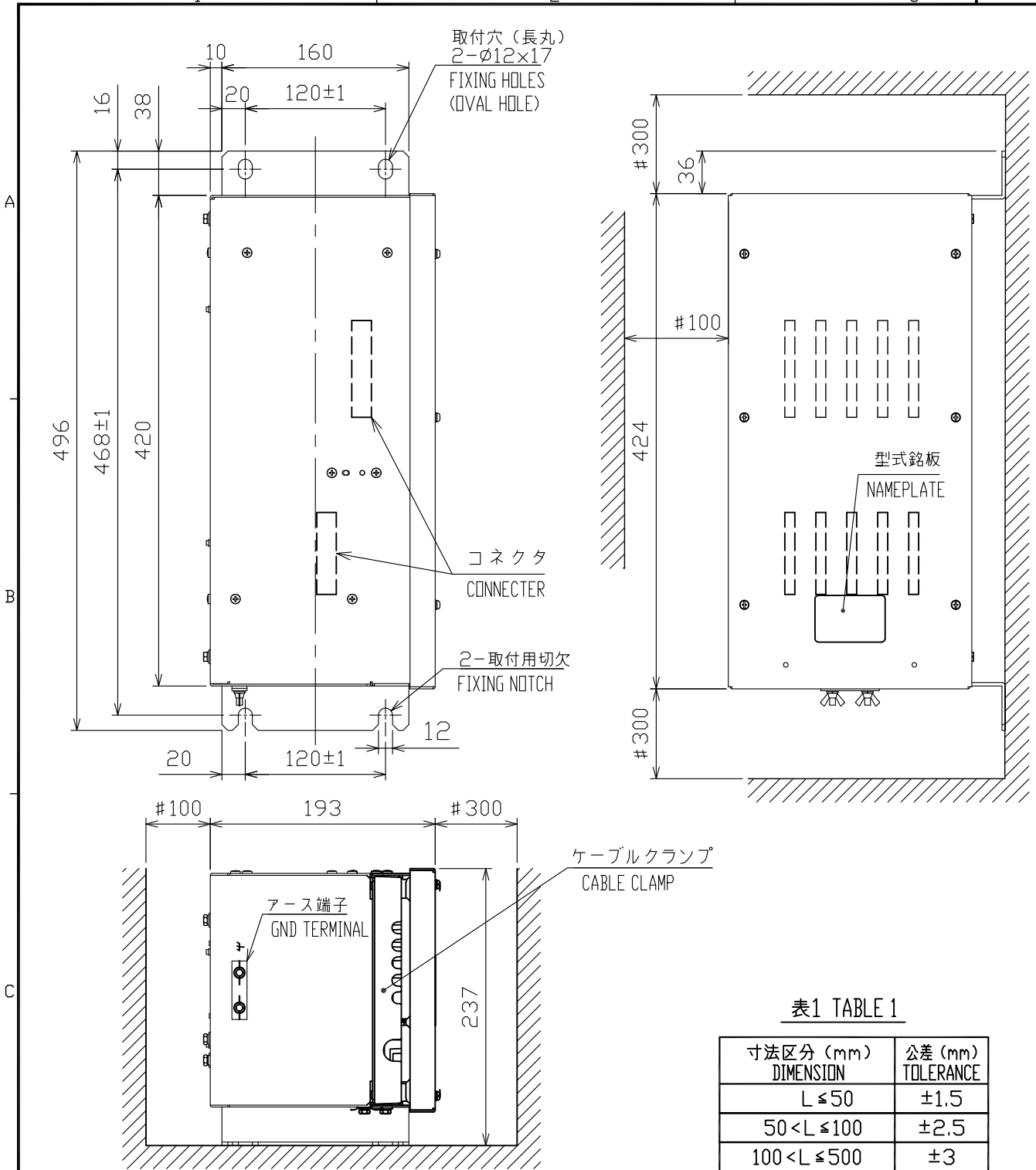
NOTE

1. TABLE 1 INDICATES TOLERANCE OF DIMENSIONS WHICH IS NOT SPECIFIED.
2. #: MINIMUM SERVICE CLEARANCE.
3. USE M10 BOLTS FOR FIXING THE UNIT.

DRAWN	9/Oct/2018 T. YAMASAKI	TITLE	FSV-7550
CHECKED	9/Oct/2018 H. MAKI	名称	整合箱 (側面装備)
APPROVED	9/Oct/2018 H. MAKI	外寸図	
SCALE	1/5	MASS	10 $\pm 10\%$ kg
DWG. No.	C1363-G13-A	REF. No.	10-090-751G-3
		NAME	MATCHING BOX (SIDE MOUNT)
			OUTLINE DRAWING

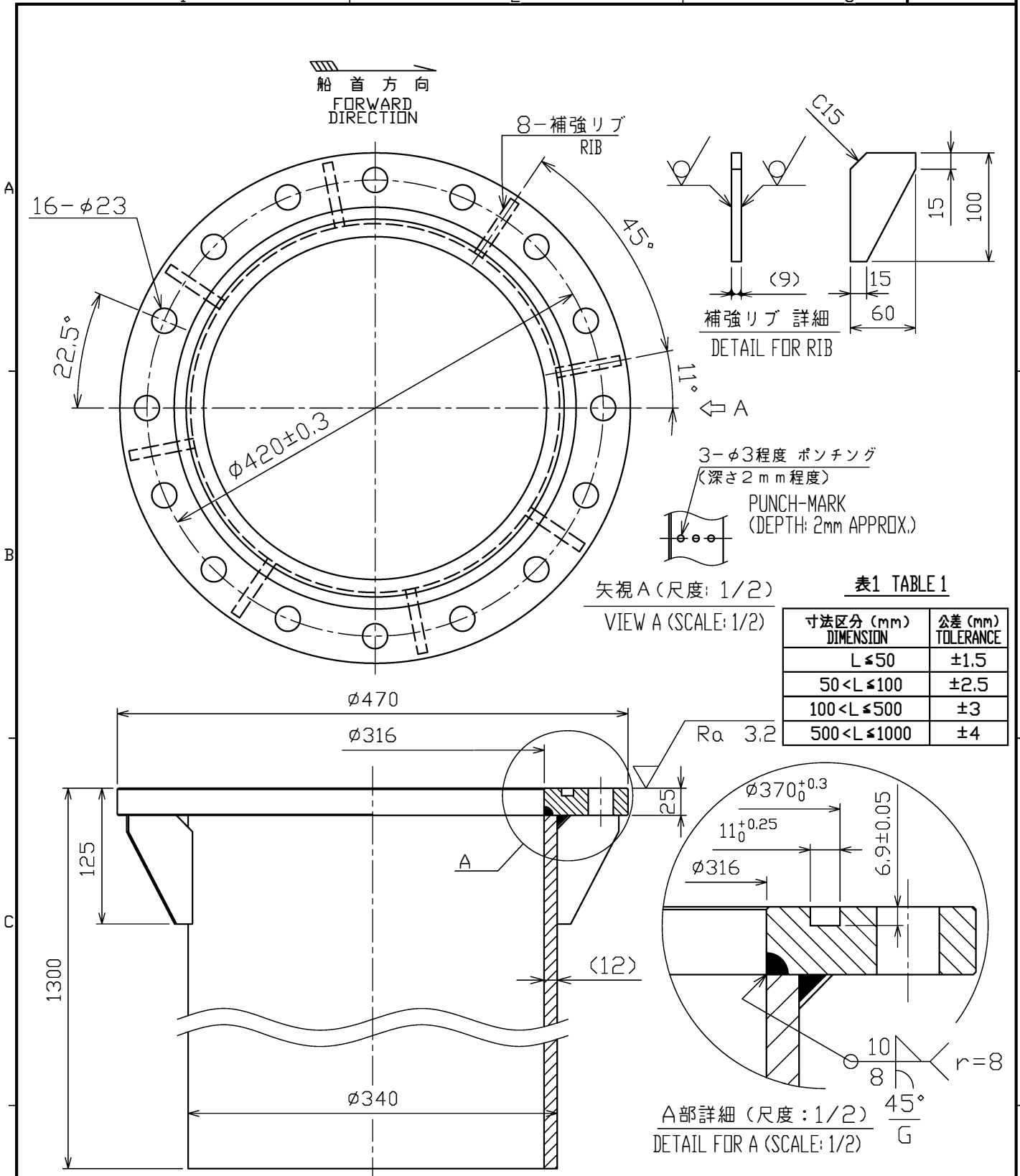

注記

1) 指定外の寸法公差は表1による。

NOTE

1. TABLE 1 INDICATES TOLERANCE OF DIMENSIONS WHICH IS NOT SPECIFIED.

DRAWN 28/Jan/2021 T. YAMASAKI		TITLE DP10-57/58
CHECKED 28/Jan/2021 H. MAKI		名称 格納タンク
APPROVED 17/Feb/2021 H. MAKI	FSV-75	外寸図
SCALE 1/5	MASS 表2参照 TABLE 2	NAME RETRACTION TANK
DWG. No. C1363-G14-D	REF. No. 10-090-550G-3	OUTLINE DRAWING

A

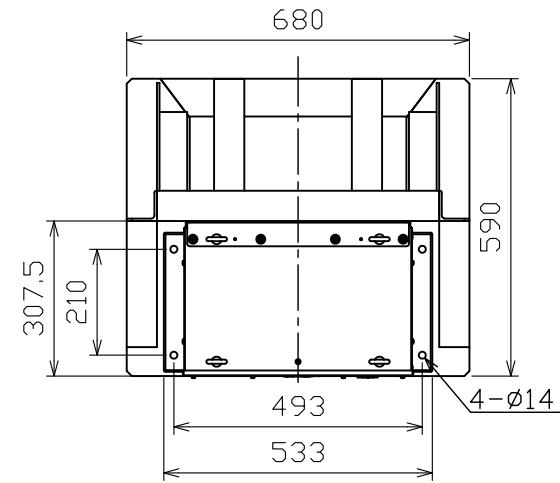

B

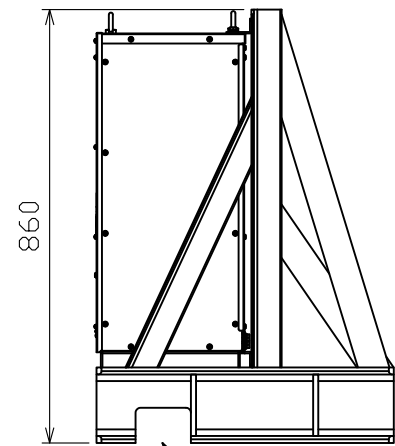
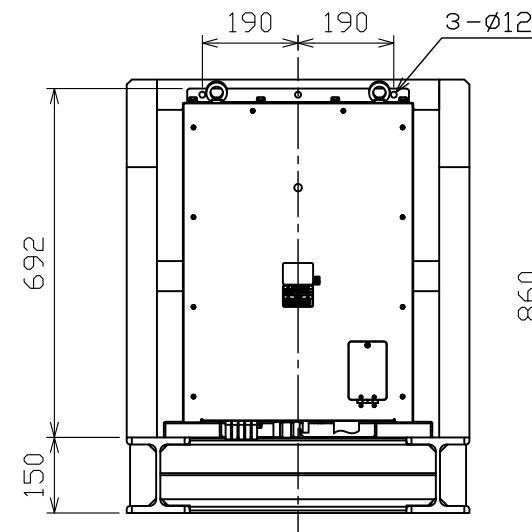

ケーブル導入口(左右いずれか)
CABLE ENTRY (ONE SIDE EITHER)

FSV-751取付寸法
DIMENSIONS FOR FSV-751 MOUNTING

FSV-751質量: 55 kg
MASS OF FSV-751: 55 kg

D

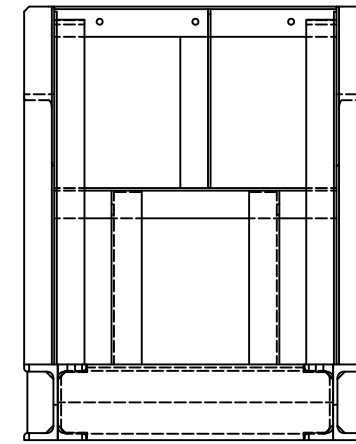
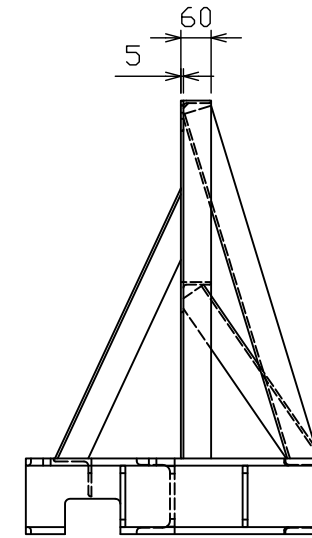
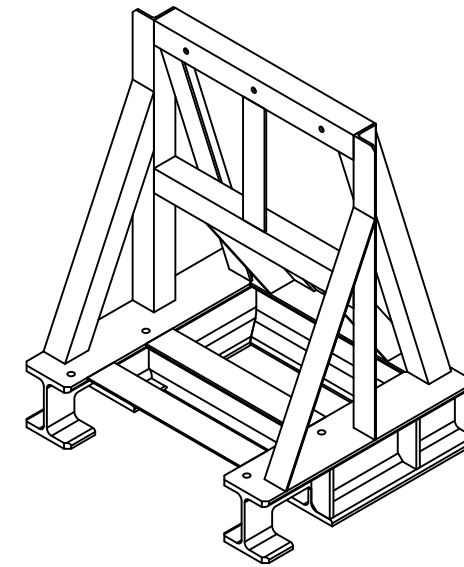
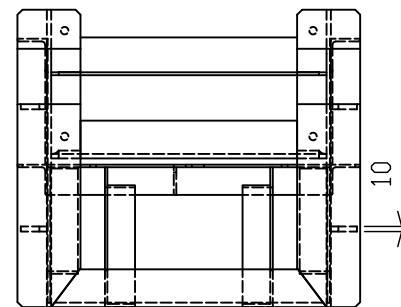
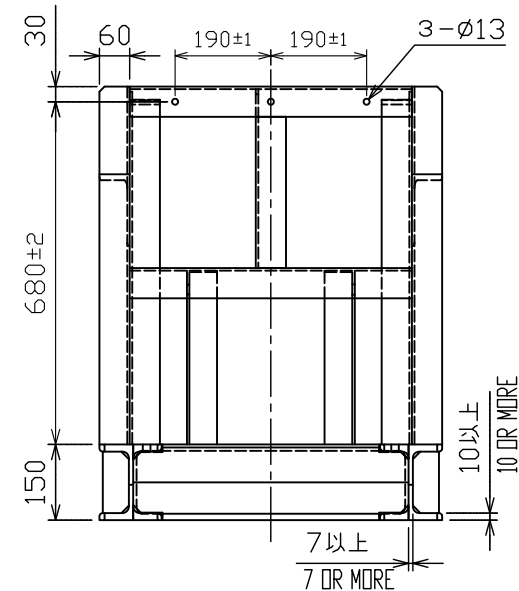
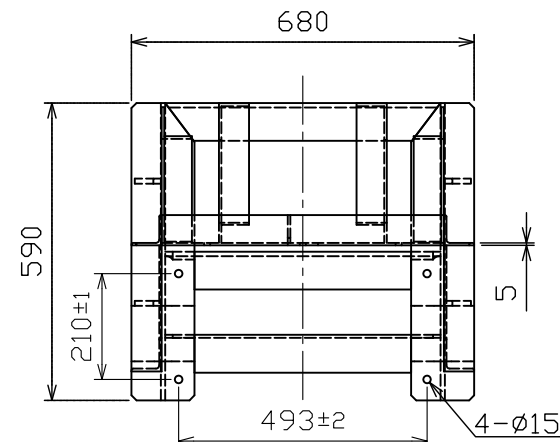

取付台製作例 (造船所手配: 設計寸法は造船所一任)
(床置装備の場合。壁掛装備は別図参照とする)

L-アングルの大きさ (上部): 60×60 (t5)以上。
ベース部アングルの大きさ (下部): H形鋼150×150 (t10以上)。

MOUNTING BASE SAMPLE (SHIPYARD SUPPLY)
(DIMENSIONS ARE DECIDED BY SHIPYARD)
(FOR FLOOR MOUNT; REFER TO ANOTHER DRAWING FOR BULKHEAD MOUNT)
L-ANGLE SIZE (UPPER): 60 X 60 (t5) OR MORE.
BASE-ANGLE (STEEL I-BEAM) SIZE (LOWER): 150x150 (W6x15-in) OR MORE.

DRAWN	19/Nov/2018 T.YAMASAKI	TITLE	MOUNTING BASE FOR FSV-751
CHECKED	19/Nov/2018 H.MAKI	名称	送受信装置取付台例 (参考)
APPROVED	19/Nov/2018 H.MAKI	FSV-75	装備要領
SCALE	1/15 MASS ±10% kg	NAME	TRANSCEIVER UNIT MOUNTING BASE (REFERENCE)
DWG. No.	C1363-Y01-A	REF. No.	INSTALLATION PROCEDURE

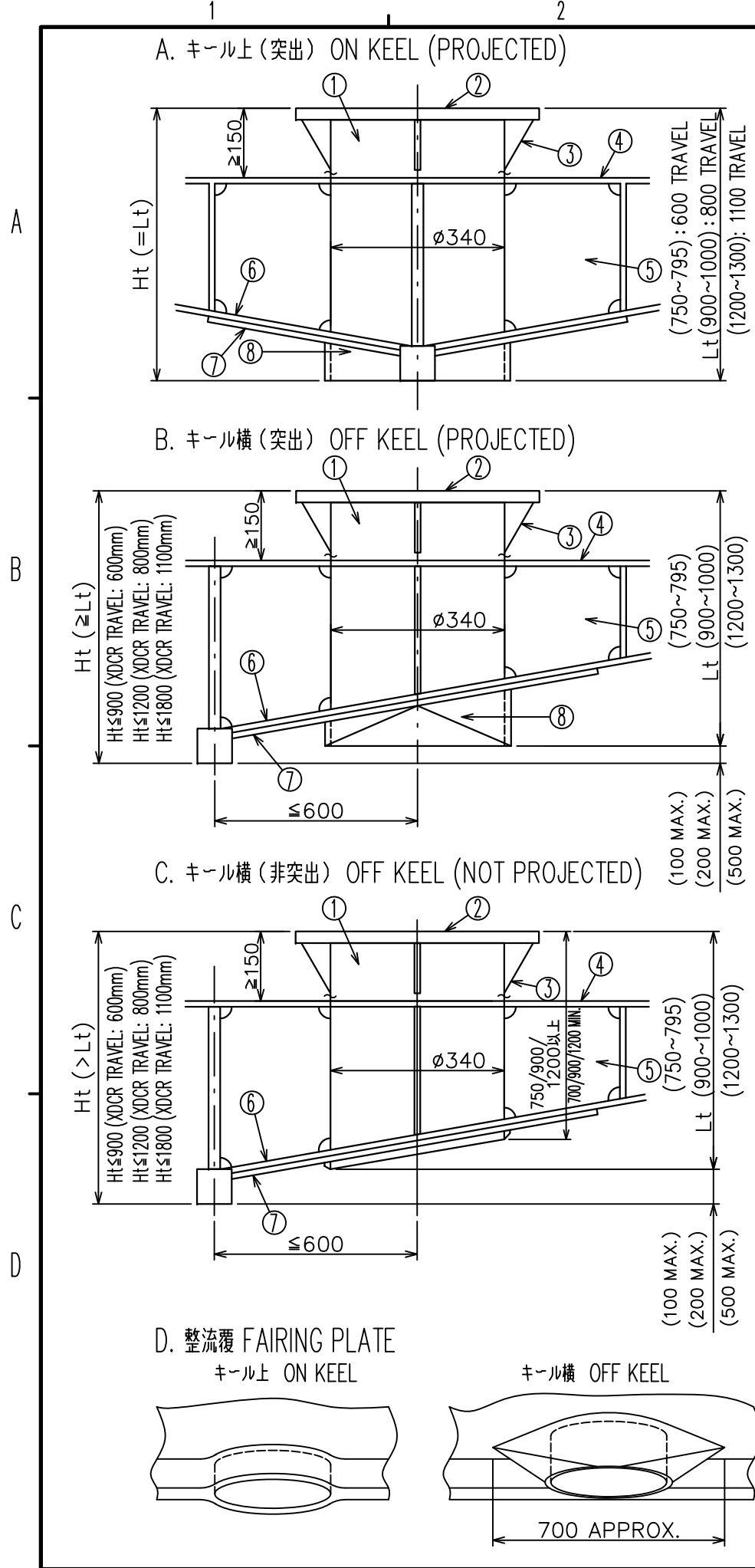

装備手順

- 次の点に注意して、格納タンクを船底板に連続スミ肉溶接する。
 - * タンクのフランジ面が標準走航時に水平になること。
 - * フランジ側面のマークが船首方向になること。
 - * 送受波器を突出させたときに送受波ビームがキールで遮られないように、フランジ面のキールよりの高さ "Ht" を図示の範囲内にすること。
 - * タンク下端がキールより下に出ないようにタンク長さ "Lt" は、"Ht" より短くする。かつ、送受波器がタンク下端より出ないように図示の範囲内にする(標準支給長900・1000・1300mm)
- 格納タンクの周囲に外径φ700以上のダブリング⑦を取付ける。また、突出装備(A・B図)の場合には、整流覆⑧(D図)を取付ける。ダブリングと整流覆には、船底板と同じ材質・肉厚のものを使用すること。
- タンク周囲と隔壁⑤を溶接する。
- 上下装置本体を格納タンクにボルト締めするのに必要なスペースとしてフランジ面の位置を二重船底板より150mm以上離す。二重船底が高い船にはB図の方法で二重船底板を下げ、スペースを確保すること。

INSTALLATION METHOD OF RETRUCTION TANK

- Install tank to hull plate with fillet welding taking the following points into account;
 - * Flange face is exactly horizontal at normal ship's trim.
 - * Bow mark on side of flange should be faced dead ahead.
 - * Allow height of flange face from keel bottom "Ht" mentioned in the drawings, otherwise transducer beam is blocked by the keel, when transducer is fully lowered.
 - * Tank's length "Lt" should be less than "Ht". If not so, bottom end of tank is placed below keel level. "Lt" is also limited as shown in the drawings so that the transducer can be fully retracted in tank. (The tank is supplied with 1000/1300 mm long as standard.
- Fit doubling plate⑦ of outer dia. φ700 around the tank on hull plate. Fit fairing plate⑧ referring to the drawing 'D' for installation method 'A' and 'B'. Use same material and thickness of doubling and fairing plate as hull plate.
- Weld the tank into bulkhead⑤ around the tank.
- Allow clearance of more than 150 mm below the flange face for easy bolting. Sink the inner hull plate as shown in the drawing 'B' for high inner hull plate.

表1 格納タンク TABLE 1 RETRUCTION TANK

型式 TYPE	ストローク TRAVEL	タンク長 TANK LENGTH
OP10-59	600 mm	900 mm
OP10-57	800 mm	1000 mm
OP10-58	1100 mm	1300 mm

品番 ITEM	品名 NAME	材質 MATERIAL	数量 Q'TY	図番 DWG. NO.	備考 REMARKS
8	整流覆 FAIRING PLATE				
7	ダブリング DOUBLING				
6	船底板 HULL PLATE				
5	油槽隔壁 BULKHEAD				
4	二重船底板 INNER HULL PLATE				
3	補強リブ REINFORCEMENT RIB				
2	タンクフランジ TANK FLANGE				
1	格納タンク RETRUCTION TANK			10-086-5801 10-090-5551/5559	

DRAWN	26/Jan/2021 T.YAMASAKI	TITLE	OP10-57/58/59
CHECKED	26/Jan/2021 H.MAKI	名称	格納タンク(鋼船用)
APPROVED	18/Feb/2021 H.MAKI	FSV-75	装備要領
SCALE	MASS kg	NAME	RETRUCTION TANK (FOR STEEL HULL)
DWG. No.	C1363-Y02-D	REF. No.	INSTALLATION PROCEDURE

A

B

C

D

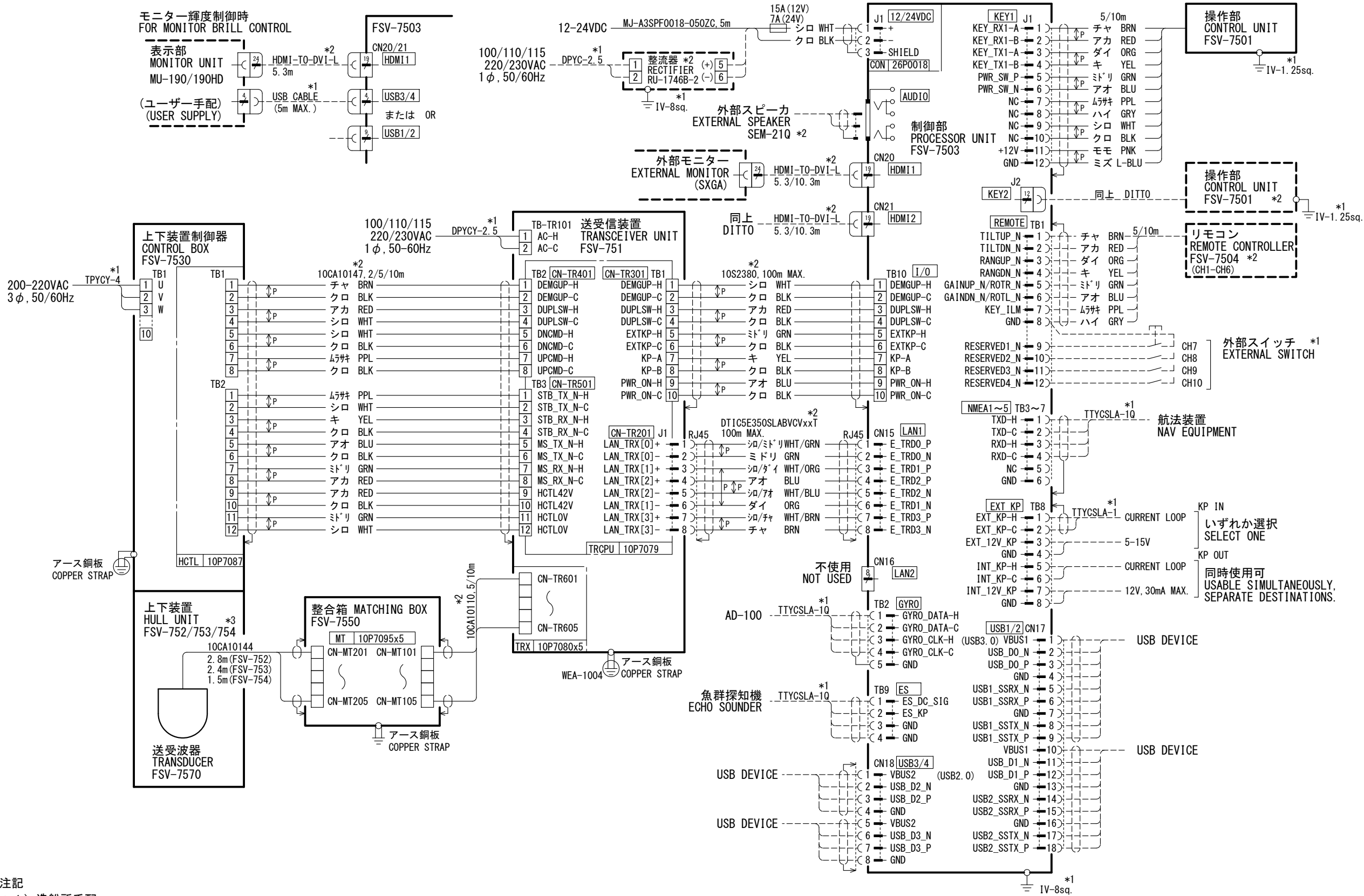

- 注記
 * 1) 造船所手配。
 * 2) オプション。
 * 3) FSV-752は国内のみ。

- NOTE
 *1: SHIPYARD SUPPLY.
 *2: OPTION.
 *3: FSV-752 IS AVAILABLE IN JAPAN ONLY.

DRAWN	1/Dec/2020 T. YAMASAKI	TITLE	FSV-75 (-3D)
CHECKED	1/Dec/2020 H. MAKI	名称	半周型カラスキャンソナー
APPROVED	17/Feb/2021 H. MAKI		相互結線図
SCALE	MASS kg	NAME	HALF-CIRCLE COLOR SCANNING SONAR
DWG No.	G1363-C01-L	REF. No.	10-090-0201-0
			INTERCONNECTION DIAGRAM

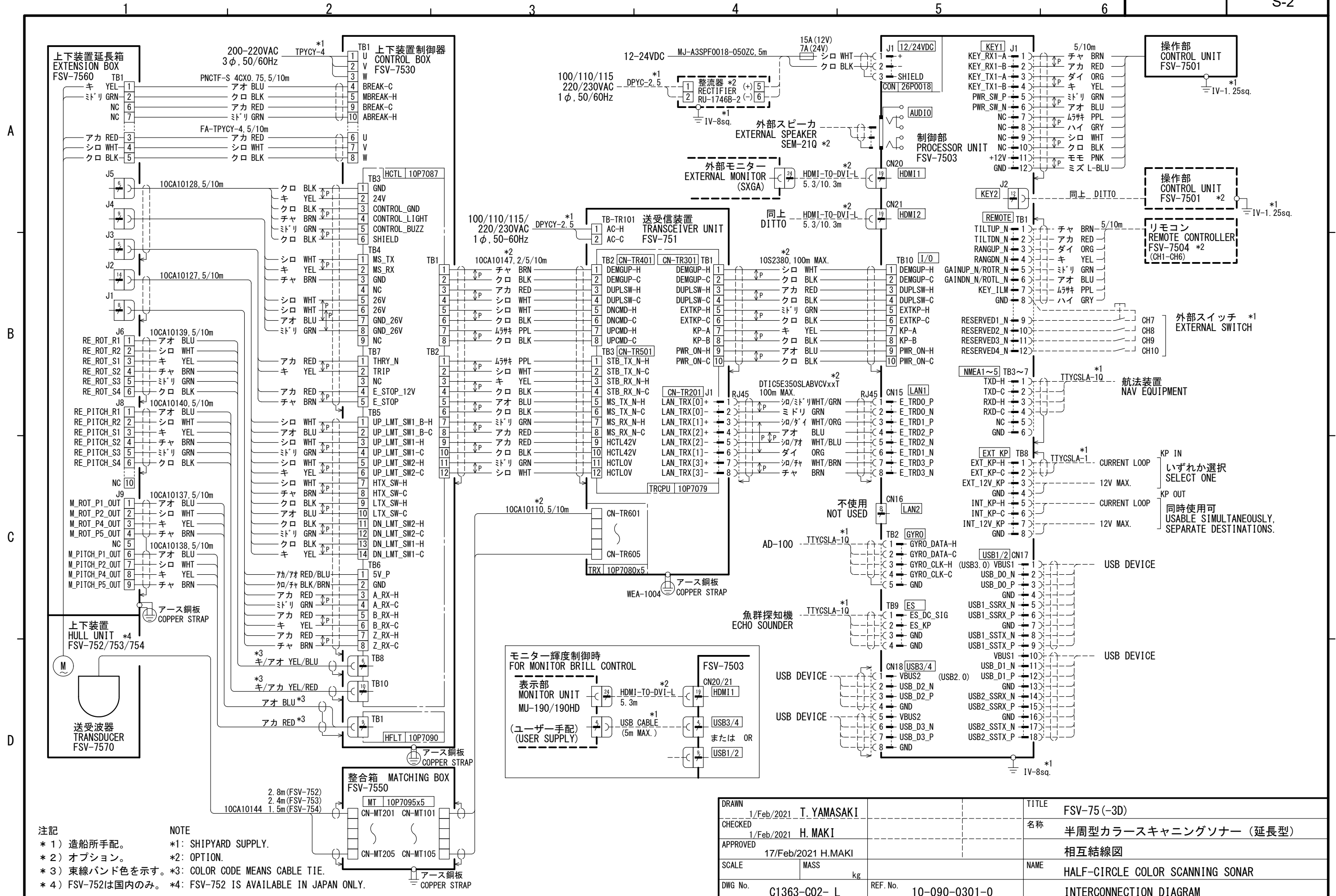

DRAWN	1/Feb/2021 T. YAMASAKI	TITLE	FSV-75 (-3D)
CHECKED	1/Feb/2021 H. MAKI	名称	半周型カラスキャンソナー (延長型)
APPROVED	17/Feb/2021 H. MAKI		相互結線図
SCALE	MASS kg	NAME	HALF-CIRCLE COLOR SCANNING SONAR
DWG No.	G1363-C02-L	REF. No.	10-090-0301-0
			INTERCONNECTION DIAGRAM