(ELECTRONIC CHART DISPLAY AND INFORMATION SYSTEM)

SAFETY INSTRUCTIONS	i
SYSTEM CONFIGURATION	ii
EQUIPMENT LISTS.....	v
1. MOUNTING.....	1-1
1.1 Monitor Unit.....	1-1
1.2 ECDIS Control Unit/Track Control Unit.....	1-1
1.3 Processor Unit	1-4
1.4 Sensor Adapters (option).....	1-6
1.5 Intelligent HUB (option).....	1-7
1.6 Switching HUB (option).....	1-8
1.7 Radar Connection Box (option).....	1-8
2. WIRING.....	2-1
2.1 Processor Unit	2-3
2.2 Monitor Unit.....	2-13
2.3 Sensor Adapters (option).....	2-15
2.4 Intelligent HUB (option).....	2-32
2.5 How to Extend the Control Unit Cable (option).....	2-33
2.6 Radar Connection Box (option).....	2-37
2.7 Raytheon Anschutz Autopilot NP-5400.....	2-41
3. ECN-303/304 (OPTION)	3-1
3.1 How to Install the Console	3-1
3.2 How to Dismount the Rack for the Processor Unit.....	3-2
3.3 How to Connect External Cables	3-4
3.4 How to Mount the Rack for the Processor Unit.....	3-6
4. SETTING UP THE EQUIPMENT	4-1
APPX. 1 JIS CABLE GUIDE	AP-1
APPX. 2 ROD TERMINALS	AP-2
APPX. 3 RA/IF BOARD JUMPER VALUES	AP-8
PACKING LIST(S)	A-1
OUTLINE DRAWING(S)	D-1
INTERCONNECTION DIAGRAM(S)	S-1

ECF

(Elemental Chlorine Free)

The paper used in this manual
is elemental chlorine free.

FURUNO ELECTRIC CO., LTD.

9-52 Ashihara-cho,
Nishinomiya, 662-8580, JAPAN

• FURUNO Authorized Distributor/Dealer

All rights reserved. Printed in Japan

A : DEC. 2021

Pub. No. IME-44732-A

(YOSH) FMD-3200/3200BB/3300





0 0 0 1 9 9 4 1 8 1 0



SAFETY INSTRUCTIONS

The installer of the equipment must read the safety instructions before attempting to install the equipment.

 WARNING	Indicates a potentially hazardous situation which, if not avoided, could result in death or serious injury.
 CAUTION	Indicates a potentially hazardous situation which, if not avoided, can result in minor or moderate injury.

 Warning, Caution	 Prohibitive Action	 Mandatory Action
--	--	--

WARNING

 **Do not open the equipment unless totally familiar with electrical circuits and service manual.**

ELECTRICAL SHOCK HAZARD Only qualified personnel should work inside the equipment.

Turn off the power at the mains switchboard before beginning the installation. Fire, electrical shock or serious injury can result if the power is left on or is applied while the equipment is being installed.

Be sure that the power supply is compatible with the voltage rating of the equipment. Connection of an incorrect power supply can cause fire or damage the equipment.

Use only the specified power cable. Fire or damage to the equipment can result if a different cable is used.

Do not install the monitor unit, processor unit or control unit where they may get wet from rain or water splash, or in a dusty environment. Water in the units can result in fire, electrical shock, or damage the equipment.

WARNING

 **Attach protective earth securely to the ship's body.** The protective earth (grounding) is required for the AC power supply to prevent electrical shock.

CAUTION

Observe the following compass safe distances to prevent deviation of a magnetic compass:

	Standard compass	Steering compass
Processor Unit (EC-3000)	2.40 m	1.55 m
Monitor Unit (MU-190)	1.65 m	1.05 m
Monitor Unit (MU-231)	2.55 m	1.55 m
Monitor Unit (MU-270W)	0.90 m	0.55 m
ECDIS Control Unit (RCU-024)	0.30 m	0.30 m
Trackball Control Unit (RCU-026)	0.30 m	0.30 m
Intelligent HUB (HUB-3000)	1.20 m	0.75 m
Switching HUB (HUB-100)	1.00 m	0.60 m
Sensor Adapter (MC-3000S)	2.05 m	1.35 m
Sensor Adapter (MC-3010A)	0.75 m	0.50 m
Sensor Adapter (MC-3020D)	1.05 m	0.70 m
Sensor Adapter (MC-3030D)	0.90 m	0.60 m
Radar Connection Box (RCB-002)	1.45 m	0.95 m

SYSTEM CONFIGURATION

System with one processor unit

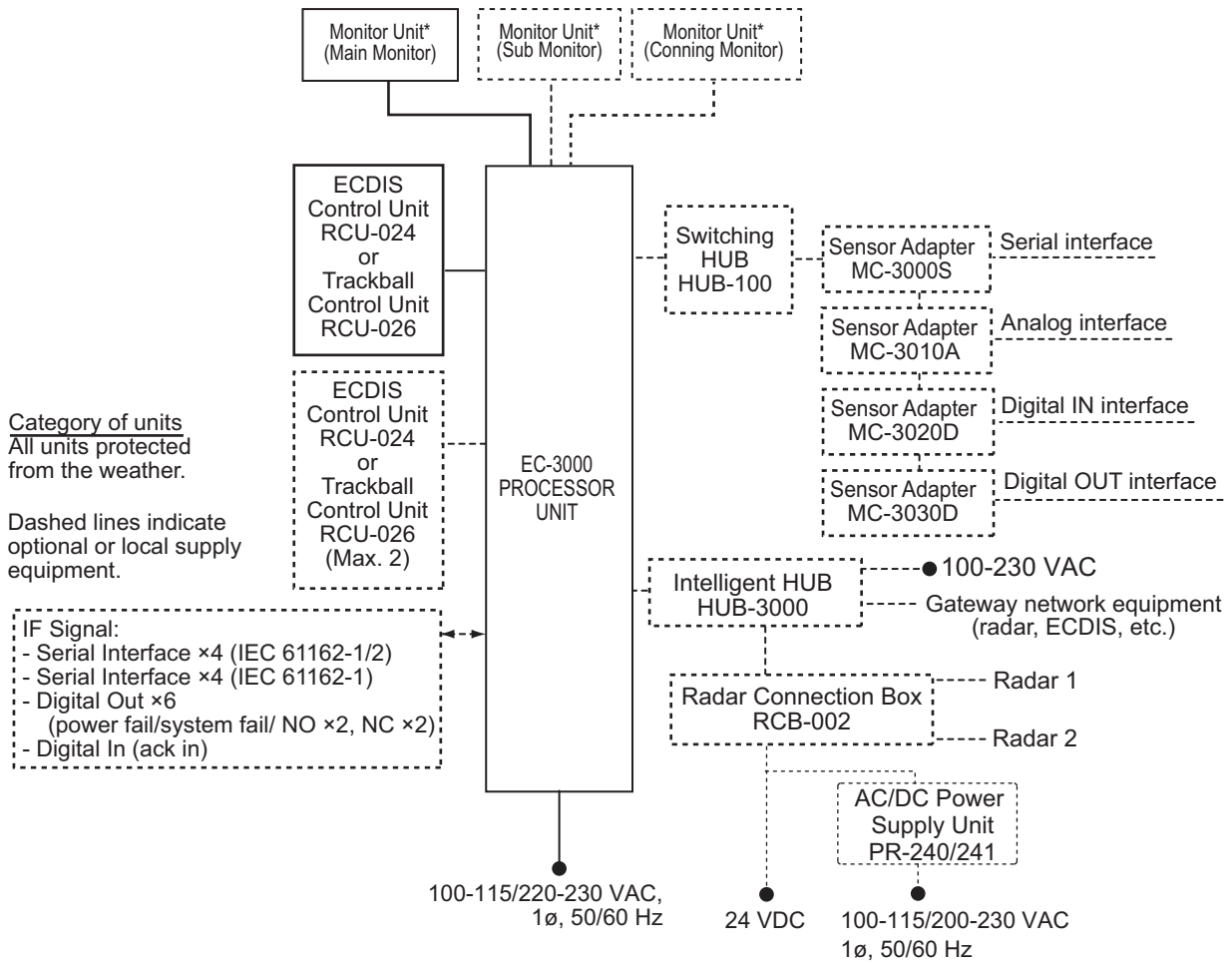

*: For the monitors available for connection with the ECDIS, see page iv.

System with two processor units

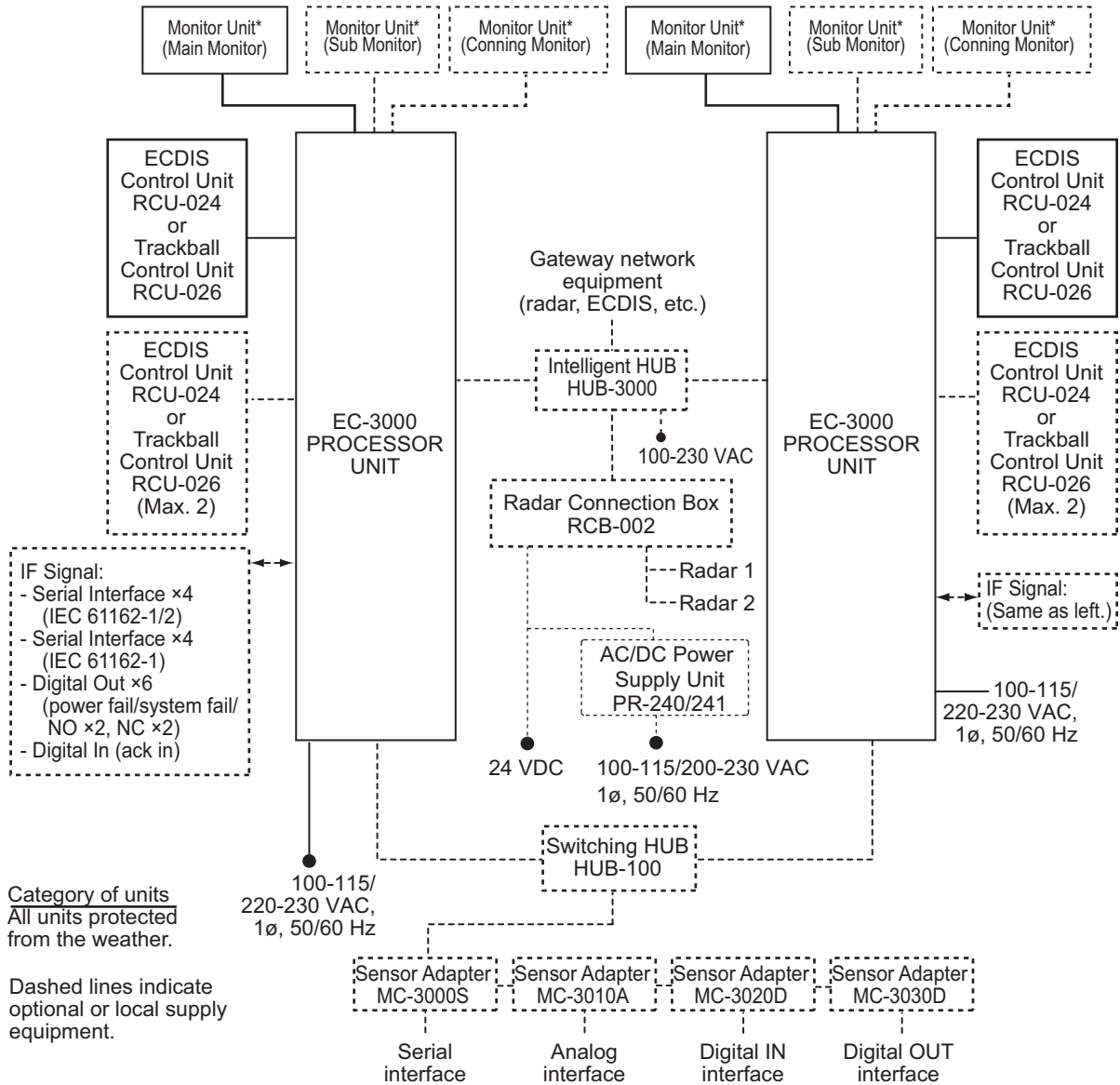

*: For the monitors available for connection with the ECDIS, see page iv.

Monitors compatible with the ECDIS

The following monitors are available for connection with the ECDIS:

Maker	Model	Viewing distance
FURUNO	MU-190* ¹	1.02 m
	MU-231* ²	1.2 m
	MU-201CE	1.0759 m
	MU-231CE	1.0138 m
	MU-270W* ²	1.02 m
Hatteland Technology	JH19T14 FUD	1.011 m
	JH20T17 FUD	0.878 m
	JH23T12 FUD* ³	1.011 m
	JH23T14 FUD	1.011 m
	JH26T11 MMD* ³	0.985 m
	HD19T21 MMD* ³	1.010 m
	HD24T21 MMD* ³	0.951 m
	HD24T22 FUD	0.951 m
	HD26T21 MMD	0.985 m
	HD26T22 MMD* ³	0.985 m
	HD26T22 FUD	0.985 m
	HD27T22 FUD	1.070 m
	HD32T22 FUD	1.268 m
	HD55T22 FUD	2.164 m
North Invent	WA270-01.MON.01	1.02 m
	WA460-01.MON.01	1.82 m

*¹: Standard supply for FMD-3200.

*²: Standard supply for FMD-3300.

*³: Do not connect this monitor to the DVI1 port. Connection to ports other than the DVI1 port is available.

EQUIPMENT LISTS

Standard Supply

Name	Type	Code No.	Qty	Remarks
Monitor Unit	MU-190	-	1	For FMD-3200, 19-inch
	MU-231	-		For FMD-3300, 23.1-inch
	MU-270W	-		For FMD-3300, 27-inch
Processor Unit	EC-3000	-	1	
ECDIS Control Unit	RCU-024	-	1	
Trackball Control Unit	RCU-026	-	1	
Installation Materials	CP24-02100	000-020-557	1	CP24-02101 and cables
	CP24-02201	001-170-810	1	For RCU-024
	CP24-02301	001-170-910	1	For RCU-026
Accessories	FP24-00602	001-258-570	1	For EC-3000(FMD-V3)
	FP24-00607	001-623-580		For EC-3000(FMD-V5)
	FP24-00701	001-170-820	1	For RCU-024
	FP24-00801	001-170-920	1	For RCU-026
Spare Parts	SP24-00601	001-170-660	1	For 100VAC
	SP24-00602	001-170-670	1	For 220VAC

Console Type

Name	Type	Code No.	Qty	Remarks
Standard Console	ECN-303	-	1	Built-in type, monitor unit: MU-231
	ECN-304	-		Built-in type, monitor unit: MU-190
	ECN-319	-		Stand-alone type, monitor unit: MU-190
	ECN-323	-		Stand-alone type, monitor unit: MU-231
	ECN-327	-		Stand-alone type, monitor unit: MU-270W

Optional Supply

Name	Type	Code No.	Remarks
Sensor Adapter	MC-3000S	-	Serial IN/OUT type
	MC-3010A	-	Analog IN
	MC-3020D	-	Digital IN
	MC-3030D	-	Digital OUT
Radar Connection Box	RCB-002	-	For connection of external radar
Intelligent HUB	HUB-3000	-	
Switching HUB	HUB-100	-	
AC/DC Power Supply Unit	PR-240	-	
	PR-241	-	
Ferrite Core	OP86-11	001-594-450	For PR-241

EQUIPMENT LISTS

Name	Type	Code No.	Remarks
Monitor Unit	MU-190	-	19-inch display
	MU-231	-	23.1-inch display
	MU-270W	-	27-inch display
	HD26T22-FUD-MA4-FAGA	-	26-inch display
ECDIS Control Unit	RCU-024	-	
Trackball Control Unit	RCU-026	-	
Bracket Assembly	OP26-5	000-016-270	For MU-190, w/knobs
	OP26-15	001-116-730	For MU-231
	OP26-30	001-439-060	For MU-270W
IPX2 Kit	OP24-23	001-171-780	For EC-3000
Flush Mount	OP24-24	001-171-790	For RCU-024
	OP24-27	001-171-820	For RCU-026
Connection Stand (19)	OP24-25	001-171-800	For RCU-024, FMD-3200
Connection Stand (23)	OP24-26	001-171-810	For RCU-024, FMD-3300
Case Gasket	OP24-28	001-169-970	For MC-3000S
	OP24-29	001-169-960	For MC-3010A/3020D/3030D
Hood Assembly	OP26-6	001-080-930	For MU-190
	OP26-16	001-116-740-01	For MU-231
Flush Mount Kit	OP26-12	001-116-280	For MU-190
	OP26-13	001-116-290	For two MU-190s
	OP26-18	000-017-273	For two MU-231s
	OP26-14	001-116-300	For three MU-190s
	OP26-19	000-017-274	For three MU-231s
	OP26-17	001-116-750	For MU-231
Flush Mount Assembly (Rear)	OP26-31	001-439-070	For MU-270W
Mounting Bracket	OP26-21	001-139-310	For MU-190
Monitor Replacement Kit	OP26-22	001-139-320	For MU-190, flush mounting
	OP26-23	001-139-360	For MU-190, desktop mounting
	OP26-26	001-139-390	For MU-190, hood
	OP26-27	001-139-570	For MU-231, desktop mounting
Control Unit Replacement Kit	OP24-31	001-181-700	For RCU-024
Hood Assembly	OP26-24	001-139-370	For MU-190
	OP26-25	001-139-380-01	For MU-231
Hood Assembly (Front)	OP26-32	001-439-090	For MU-270W
Hood Assembly (Rear)	OP26-33	001-439-110	For MU-270W
Connection Stand (27)	OP26-34	001-462-860	For MU-270W
Terminal Opener	OP24-33	001-188-850	
EC-3000 Attachment Kit	OP24-36	001-258-180	For EC-3000
Program Install Software	OP24-37	001-529-060	For EC-3000(FMD-V3)
	OP24-65	001-624-260	For EC-3000(FMD-V5)

Name	Type	Code No.	Remarks
Replacement Kit	OP24-50	000-027-446	
Unit Mounting Base	OP24-51	001-461-600	For ECN-319/323/327
FAN-LED Kit	OP24-052	001-462-730	For ECN-319/323/327
Dust Cover	26-007-1201	001-116-260-10	For MU-190
	26-007-2141	001-121-240-10	For MU-231
	26-009-1093	001-439-120	For MU-270W
	03-163-7271	001-121-230-10	For console type
Installation Materials	CP03-28900	000-082-658	LAN cable for sensor adapter, 10 m
	CP03-28910	000-082-659	LAN cable for sensor adapter, 20 m
	CP03-28920	000-082-660	LAN cable for sensor adapter, 30 m
	CP24-02900	001-208-050	LAN cable for HUB-3000, 10 m
	CP24-02910	001-208-060	LAN cable for HUB-3000, 20 m
	CP24-02920	001-208-070	LAN cable for HUB-3000, 30 m
Connector	CP03-28901	008-542-460	
Spare Parts	SP03-15001	001-042-330	For HUB-100
	SP24-00801	001-235-320	For HUB-3000
Hand Grip Assembly	FP03-09840	008-535-570	For MU-190/231/270W
Cable Assy.	DSUB9P-X2-L5M	001-188-260	For monitor unit, 5 m
	DSUB9P-X2-L5M-WP	001-207-890	For monitor unit, 5 m, waterproof type
	DSUB9P-X2-L10M	001-188-270	For monitor unit, 10 m
	DSUB9P-X2-L10M-WP	001-207-900	For monitor unit, 10 m, waterproof type
	DSUB9P-X2-A-L5M	001-252-580	Brightness control cable for monitor unit, 5 m
	DSUB9P-X2-A-L10M	001-252-590	Brightness control cable for monitor unit, 10 m
	MC1.5-W-L600	001-187-470-10	Between sensor adapters, 0.6 m
	MC1.5-W-L1000	001-187-480-10	Between sensor adapters, 1 m
	MC1.5-W-L2000	001-187-490-10	Between sensor adapters, 2 m
	MC1.5-W-L3000	001-187-500-10	Between sensor adapters, 3 m
	TET-16-045A-2(L5M)	000-194-754-10	For RCU-024, 5 m
	TET-16-045A-3(L10M)	000-194-755-10	For RCU-024, 10 m
	TET-16-045A-4(L20M)	000-194-756-10	For RCU-024, 20 m
	TET-16-045A-5(L30M)	000-194-757-10	For RCU-024, 30 m
	6TPSH-XH12X2-L5.0SP2	001-186-310-10	For RCU-026, 5 m
	6TPSH-XH12X2-L10SP2	001-186-320-10	For RCU-026, 10 m
	6TPSH-XH12X2-L20SP2	001-186-330-10	For RCU-026, 20 m
	6TPSH-XH12X2-L30SP2	001-186-340-10	For RCU-026, 30 m
	DVI-D/D S-LINK 5M	001-132-960-10	For monitor unit, 5 m
	DVI-D/D S-LINK 10M	001-133-980-10	For MU-190, 10 m
	OP24-32	001-188-300	USB cable (between processor and control units), 5 m

EQUIPMENT LISTS

Name	Type	Code No.	Remarks
Cable Assy.	MJ-A10SPF0020A-050+	001-283-370	Cable between RCB-002 and external radar, 5 m
	MJ-A10SPF0020A-100+	001-283-380	Cable between RCB-002 and external radar, 10 m
	MJ-A10SPF0020A-200+	001-283-390	Cable between RCB-002 and external radar, 20 m
	MJ-A10SPF0020A-300+	001-283-400	Cable between RCB-002 and external radar, 30 m
	AI.14-8AI.34-6L430	001-460-190	For ECN-319/323/327, cable between MC-3010A/3020D/3030D
	IOK-V0024-2	001-460-210	For ECN-319/323/327, cable between HUB-3000 and processor unit
Operator's Manual	OME-44730-*	000-176-125-**	Hard copy manual, English
	OMJ-44730-*	000-176-124-**	Hard copy manual, Japanese
LOP Instruction Manual	E42-01411-*	000-190-356-**	Hard copy manual, English
Radar Instruction Manual	E42-01502-*	000-190-843-**	Hard copy manual, English
Crimping Tool	CRIMPFOX10S	001-206-920	For ferrule

1. MOUNTING

NOTICE

Do not apply paint, anti-corrosive sealant or contact spray to coating or plastic parts of the equipment.

Those items contain organic solvents that can damage coating and plastic parts, especially plastic connectors.

1.1 Monitor Unit

To mount the monitor unit, see the operator's manual supplied with the monitor unit.

Make sure that the ground wire is connected between the earth terminal on the chassis and the ship's earth.

1.2 ECDIS Control Unit/Track Control Unit

The control units can be mounted on a desktop, with or without the KB fixing metal (supplied), which mounts the control units at an angle. The control unit also can be mounted in a console panel using the optional kit.

Note: The control unit RCU-024 can be used instead of the RCU-018 (for FEA-2xx7) mounted in the connection stand (OP03-184 or OP26-20) using the option OP24-31.

Mounting considerations

When you select a mounting location, keep in mind the following points:

- Select a location where the control unit can be operated conventionally.
- Locate the unit away from heat sources because of heat that can build up inside the cabinet.
- Locate the equipment away from places subject to water splash and rain.
- Leave sufficient space for maintenance and service, referring to the outline drawings at the back of this manual.

Note: The outline drawing number for the ECDIS control unit (RCU-024) is different depending on the serial number, as shown below:

- "199999" or earlier: See "C4473-G02" to "C4473-G04".
- "200001" or later: See "C4473-G18" to "C4473-G20".
- Determine the mounting location considering the length of the signal cable between the control unit and the processor unit.
- A magnetic compass will be affected if the control unit is placed too close to the magnetic compass. Observe the compass safe distances on page i to prevent compass malfunction.

1. MOUNTING

- Make sure that the ground wire is connected between the earth terminal on the chassis and the ship's earth.
- Fasten the USB cable with the cable tie (supplied) to the cable routing peg.

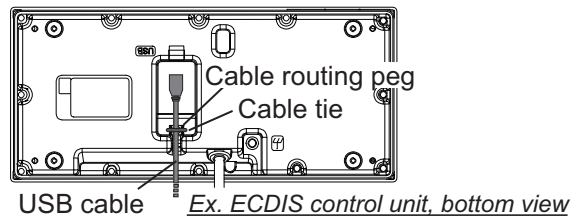

1.2.1 Desktop Mounting

Fixing with KB fixing metal

1. Fix the KB fixing metal to the bottom of the control unit.
2. Fix the unit with self-tapping screws (5x20, local supply).

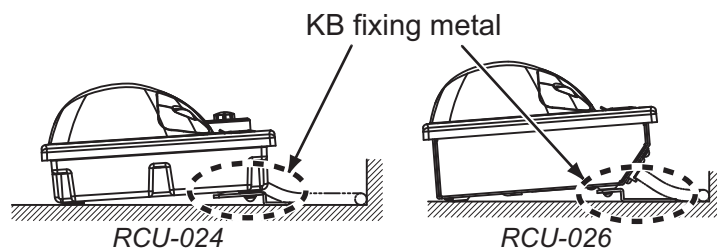

Fixing without KB fixing metal

1. Drill four mounting holes of 5 mm (RCU-024) or 4 mm (RCU-026) diameter referring to the outline drawing at the back of this manual.
2. Fix the control unit with four screws (RCU-024: M4, RCU-026: M3) from under side of the desktop. (The M4 screws with a sufficient length for the thickness of the desktop should be provided locally.)

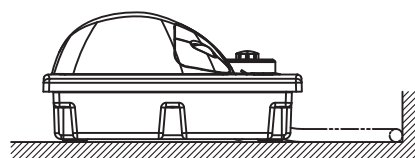
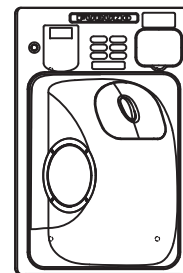
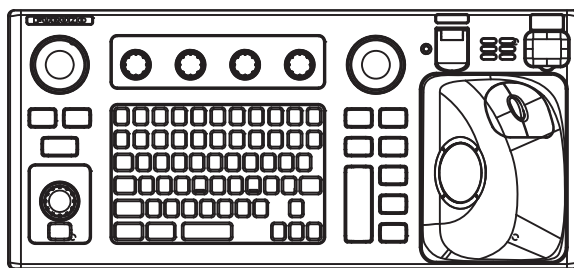

RCU-025

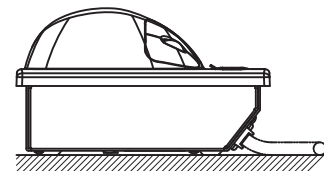

RCU-026

1.2.2 Flush mounting

Use the optional flush mount kit to mount the control unit in a console panel.

Flush mount kits for RCU-024/025

Control Unit	Type	Code No.
RCU-024	OP24-24	001-171-790
RCU-026	OP24-27	001-171-820

1. Prepare a cutout in the mounting location as shown on below.

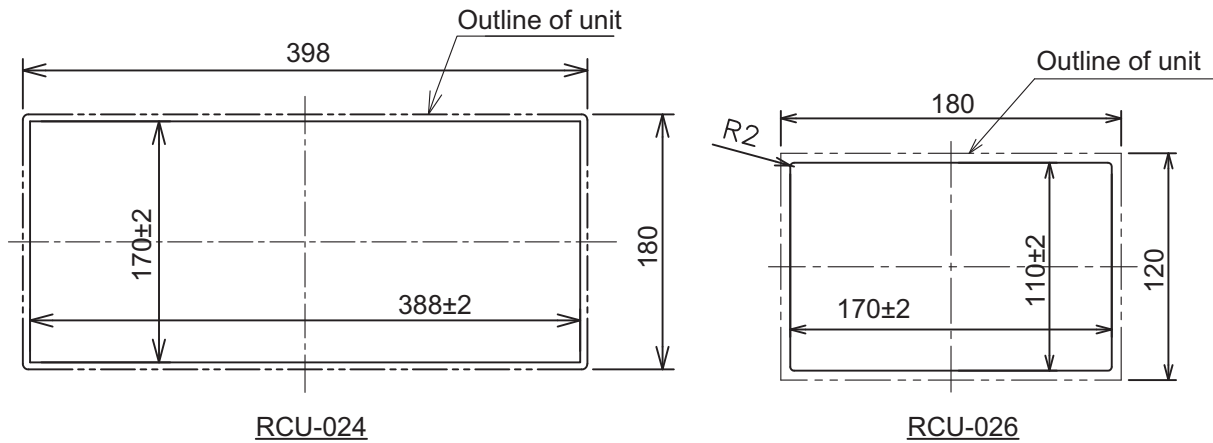

2. Set the control unit to the cutout.
3. Attach the mounting plate to the control unit with four screws from the rear side.
4. Screw the wing screw to each mounting plate and then insert hex. bolt to each wing screw.
5. Fasten each wing screw and then fasten the wing nuts as shown in figure below.

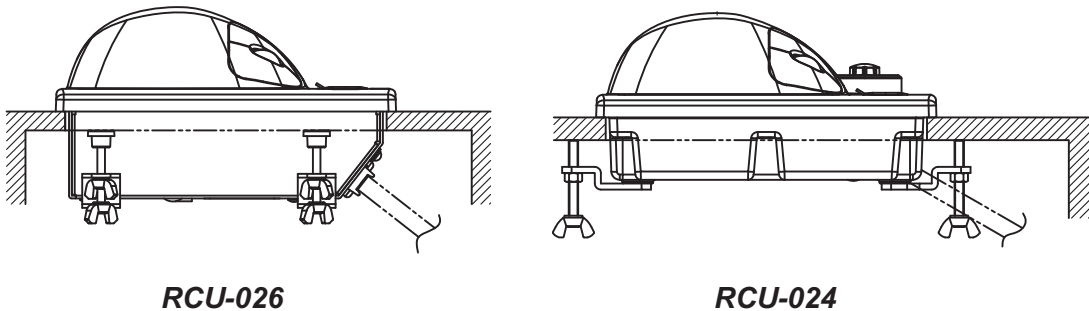

Side view of control units

1.3 Processor Unit

1.3.1 Mounting considerations

When you select a mounting location, keep in mind the following points:

- Locate the processor unit away from heat sources because of heat that can build up inside the cabinet.
- The vibration at the mounting location should be minimum.
- Locate the equipment away from places subject to water splash and rain.
- Make the service clearance of 100 mm in front of the vent hole (left side).
- Leave sufficient space at the sides and rear of the unit to facilitate maintenance.
- Make sure that the ground wire is connected between the earth terminal on the chassis and the ship's earth.
- A magnetic compass will be affected if the processor unit is placed too close to the magnetic compass. Observe the compass safe distances on page i to prevent compass malfunction.
- Do not remove the dummy plate to prevent the wrong operation of the power switch. The items behind the plate are for use by the serviceman.

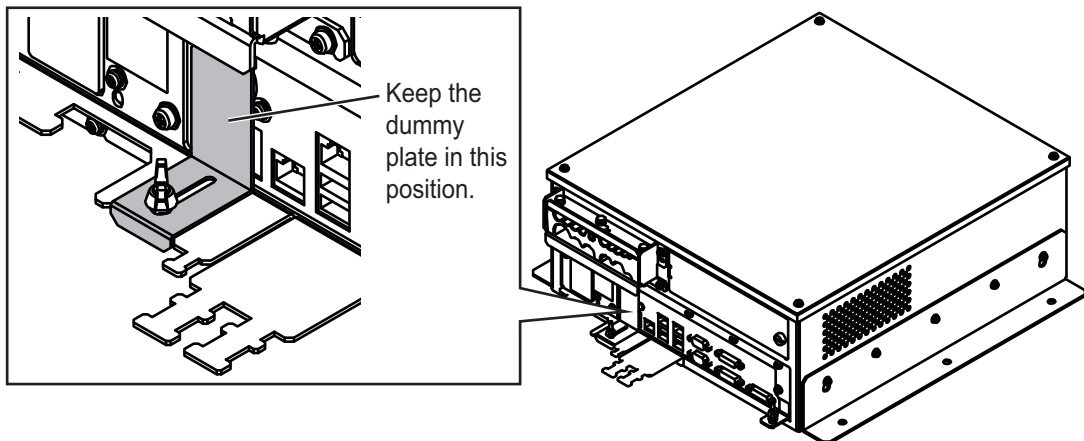

- Mount the processor unit on the floor, or on a bulkhead with the following direction (horizontal), because of the DVD drive unit.

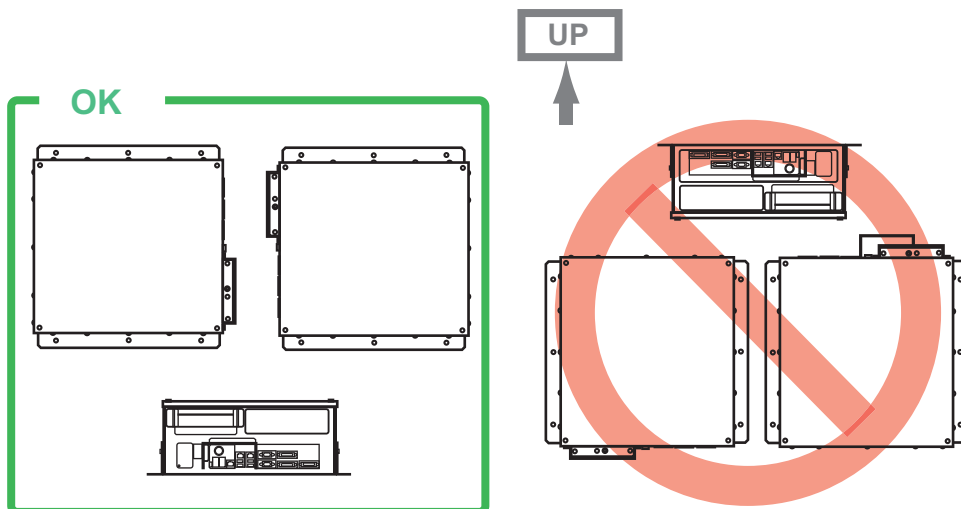

1.3.2 How to mount the processor unit

Use six bolts (M6, local supply) to mount the processor unit.

1. Use 10 binding head screws (M4x8, supplied) to attach the chassis bases 1 and 2 to the processor unit.

Note: For bulkhead mounting, attach the chassis base 2 so that the notches on it are facing the deck.

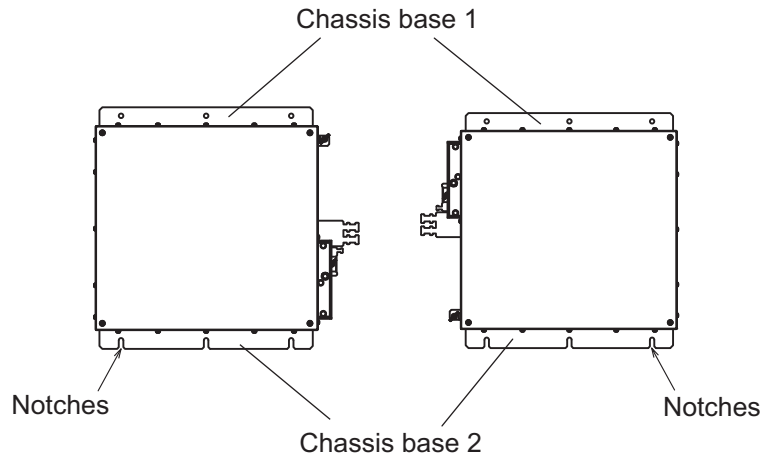

2. Use six bolts (M6, local supply) to fix the processor unit.

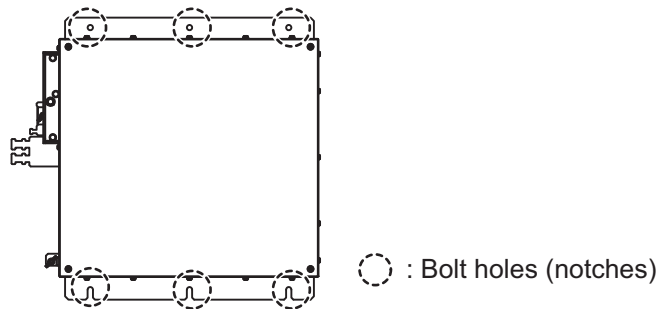

1.4 Sensor Adapters (option)

Mounting considerations

When you select a mounting location, keep in mind the following points:

- Locate the adapter away from heat sources because of heat that can build up inside the cabinet.
- The vibration should be minimal.
- Locate the equipment away from places subject to water splash and rain.
- Make sure that the ground wire is connected between the earth terminal on chassis and the ship's earth.
- Leave sufficient space at the sides and rear of the unit to facilitate maintenance.
- A magnetic compass will be affected if the adapter is placed too close to the magnetic compass. Observe the compass safe distances at the front of this manual to prevent interference to a magnetic compass.
- Select the mounting location considering the numbers of the sensor adapters connected.

Maximum eight MC-3000S can be connected to a sensor network (for the redundant connection:16).

Maximum 10 sensor adapters (MC-3010A/3020D/3030D) can be connected to a MC-3000S. However, note that five MC-3010A can be connected.

- Select the mounting location so that the length of cables among the sensor adapters (MC-3000S, 3010A, 3020D and 3030D) is less than 6 m. If the length is more than 6 m, the equipment may not work properly.

How to mount the sensor adapter

1. Unfasten four binding screws to remove the cover from the sensor adapter.
2. Fasten four self-tapping screws (4x20, supplied) to fix the sensor adapter.
3. Reattach the cover.

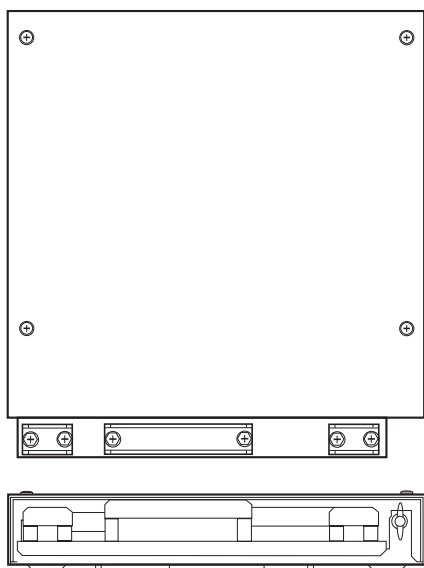

MC-3000S

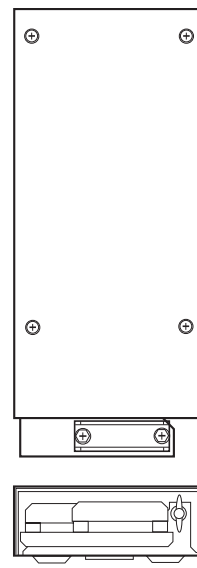

MC-3010A/3020D/3030D

1.5 Intelligent HUB (option)

Use the optional Intelligent HUB (HUB-3000) to connect gateway network equipment. This network cannot be connected with the LAN network on board. Note that a commercial PC cannot be connected in this network, other than for the maintenance.

Mounting considerations

When you select a mounting location, keep in mind the following points:

- Locate the adapter away from heat sources because of heat that can build up inside the cabinet.
- The vibration should be minimal.
- Locate the equipment away from places subject to water splash and rain.
- Make sure that the ground wire is connected between the earth terminal on chassis and the ship's earth.
- Leave sufficient space at the sides and rear of the unit to facilitate maintenance.
- A magnetic compass will be affected if the adapter is placed too close to the magnetic compass. Observe the compass safe distances at the front of this manual to prevent interference to a magnetic compass.

How to mount the HUB-3000

1. Use two binding screws (M3x6, supplied) to attach the cable clamp (supplied) to the bottom of the HUB-3000.

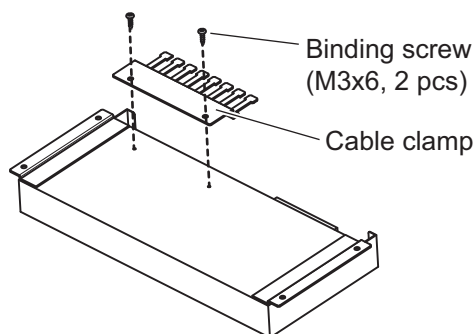

HUB-3000, bottom view

2. Fasten four self-tapping screws (4x20, supplied) to fix the unit.

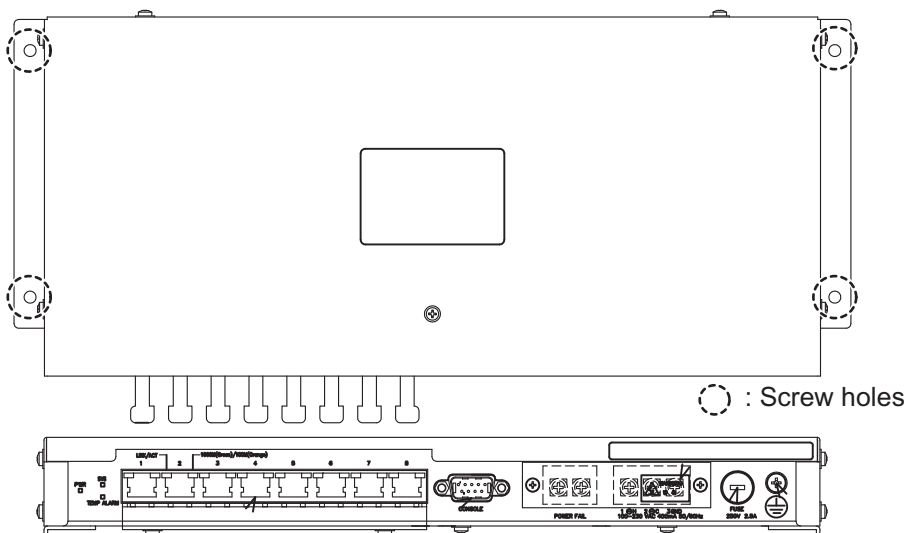

1.6 Switching HUB (option)

Use the optional Switching HUB (HUB-100) to connect sensor networks. This network cannot be connected with the LAN network on board. Note that a commercial PC cannot be connected in this network, other than for the maintenance. The total length of all cables connected to the hub is 6 m.

For the mounting procedures, see the operator's manual for HUB-100 (Pub. No.OMC-35191).

Mounting considerations

When you select a mounting location, keep in mind the following points:

- Locate the adapter away from heat sources because of heat that can build up inside the cabinet.
- The vibration should be minimal.
- Locate the equipment away from places subject to water splash and rain.
- Make sure that the ground wire is connected between the earth terminal on chassis and the ship's earth.
- Leave sufficient space at the sides and rear of the unit to facilitate maintenance.
- A magnetic compass will be affected if the adapter is placed too close to the magnetic compass. Observe the compass safe distances at the front of this manual to prevent compass malfunctions.

1.7 Radar Connection Box (option)

You can display signals from up to two external radars on the chart display by using the RCB-002. The RCB-002 must be connected via the Gateway Network.

Mounting considerations

Keep the following points in mind when selection a mounting location:

- Locate the unit away from heat sources. Heat can build up inside the cabinet, causing undue wear to electrical components.
- Take into account the length of the cables to connected to the unit when selecting an installation location.
- Fix the unit firmly so that rough seas and vibrations do not cause the unit to move in any manner.
- Locate the unit away from areas which may be subject to splash or rain.
- Leave sufficient space at the sides and rear of the unit to facilitate maintenance.
- A magnetic compass will be affected if the equipment is placed too close to the magnetic compass. Observe the compass safe distances at the front of this manual to prevent interference to a magnetic compass.
- Vibration at the mounting location should be minimum.

1. Referring to the outline drawing at the back of this manual, drill four holes ($\phi 5 \times 20$) in the mounting location.
2. Fix the unit firmly in place using $\phi 5 \times 20$ self-tapping screws.

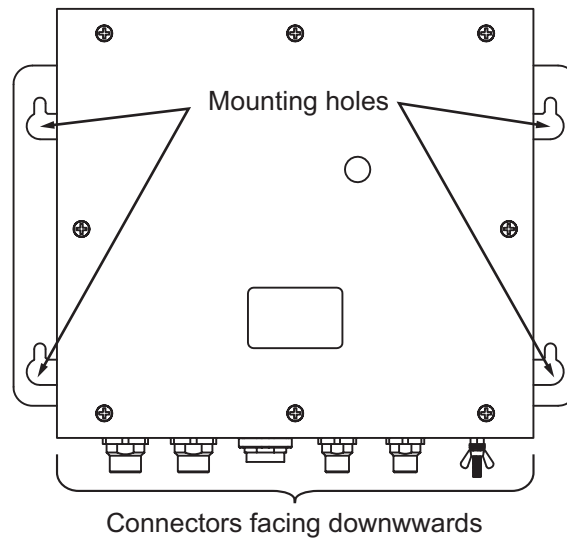

1. MOUNTING

This page is intentionally left blank.

2. WIRING

The illustration on this page shows the general connection between FMD-3200/3300 and external equipment. For detailed information, see the interconnection diagram. Many of the cables mentioned are JIS (Japan Industry Standard) cables. If not available locally, use the equivalent. See the cable guide in the Appendix for how to select equivalent cables. For other monitor unit wiring, see the applicable operator's manual.

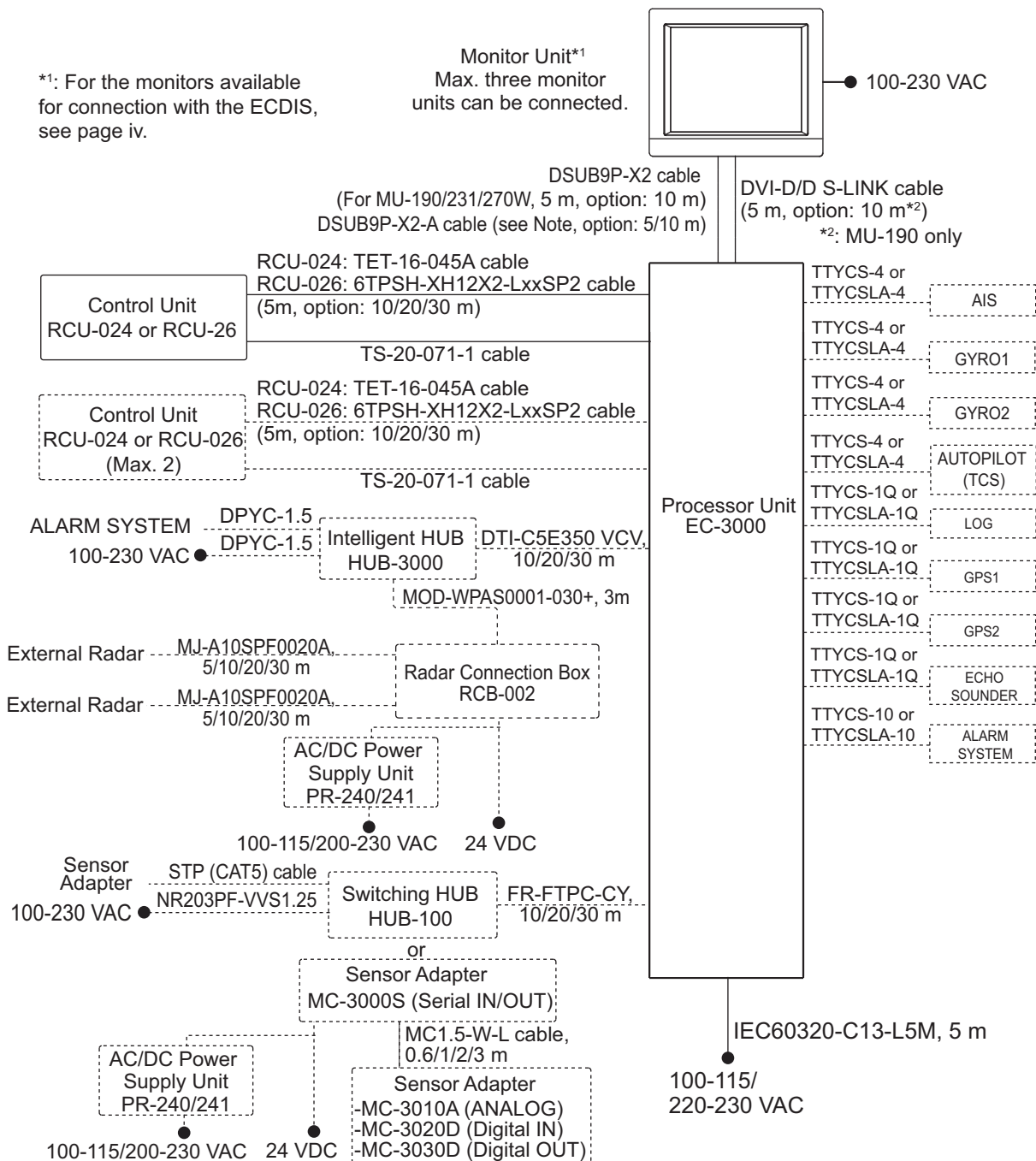

Note: If the MU-201, MU-231CE or a Hatteland Technology monitor is connected, the DSUB9P-X2-A-L5M/L10M cable (available as an optional extra) for brilliance control is required to connect.

Notice for the network construction

- Use the optional Switching HUB (HUB-100) to connect the sensor networks. For the gateway networks, use the optional Intelligent HUB (HUB-3000).
- Do not connect the LAN network on board to the above optional HUBs. Also, commercial PCs cannot be connected to the gateway network, other than for maintenance.
- Connect to other ECDIS units and radars (FEA-2xx7, FAR-2xx7 series radars, etc) using the gateway network.
- When constructing a network with two or more FAR-2xx7 radars, an FMD-3x00 unit and using a HUB-3000, the HUB-3000 querier must be configured. For how to set the HUB-3000 querier, see the instruction manual (E42-02113).
- The processor unit does not support IGMP snooping or CGMP enabled switch.
- The processor unit does not have a router or repeater hub function.
- The Switching HUB (HUB-100) does not support IGMP snooping or CGMP enabled switch.
- When you use IEC 61162-450 compatible sensors, set [Transmission Group] on the [Common Installation Settings] menu. For how to set [Transmission Group], see the instruction manual (E42-02113).
- Modbus is only available for AMS database communication.
- To ensure the security of the FURUNO network, be sure to connect with non-FURUNO networks via the service gateway (tBOX810-83A-FL).

Notice on wiring

- To use the USB port on the control unit, connect the control unit to the processor unit, using the USB cable supplied with the control unit or optional USB cable.
- The length of the USB cable should be within 5 m to prevent equipment trouble.
- The length of LAN cables should be within 50 m.
- Use the CAT5E or CAT6 LAN cables for the network if available locally.
- If LAN cables are not available locally, use the optional LAN cables (FR-FTPC-CY for sensor network, DTI-C5E350 VCV for gateway network).
- If extension or division of the DVI or ERGB cables is necessary, use the dividers shown below.
 - DVI cable divider: DVI-12A (maker: IMAGENICS)
 - RGB divider: CIF-12H, DD-106 or WBD-14F (maker: IMAGENICS)
- Make sure that the ground wires are connected between the ground terminals on each equipment and the ship's earth.
- If a UPS (user supply) is connected to this equipment, be sure that the grounding lamp does not light.

2.1 Processor Unit

2.1.1 How to connect cables to terminals on the processor unit

Use screws (M3×6, supplied) to attach the wiring plate 1 and wiring plate 2 to the processor unit. Connect the cables to the connectors at the front of the processor unit, referring to the following figure. After the connection, bind cables to the appropriate fixing metal with the cable ties (supplied).

Slide the plate toward the unit to hide LED and switches.



For the cables from the monitor unit (type: DVI-D/D SLINK5M/10M (MU-190 only), DSUB9P-X2-L5/10M) and ground wire, connect them to the processor unit directly (without fixing to a wiring plate). Tighten the fixing screws on these connectors to prevent disconnection from the processor unit.

Note: Connect the cables so that they do not interfere with the opening or closing of the DVD tray.

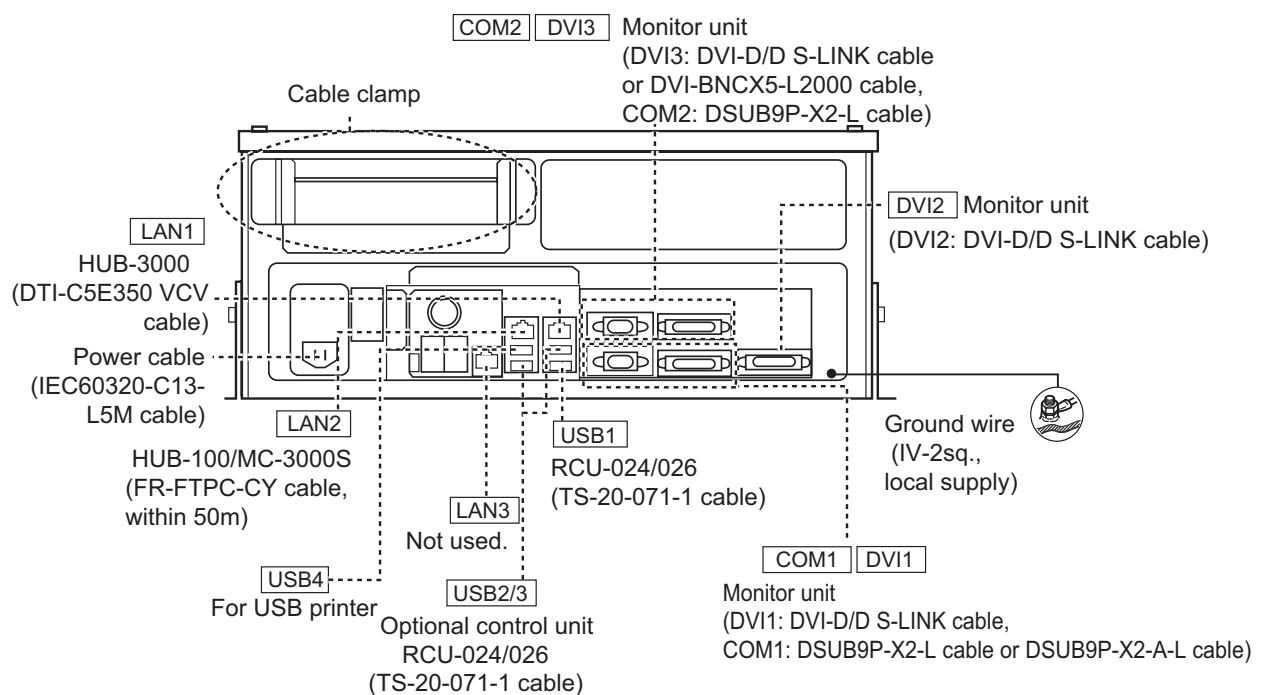

Cables connected at the wiring plate 1

- USB cables from the control units
- Printer cable
- LAN cable (type: DTI-C5E350 VCV) from the HUB-3000
- LAN cable (type: FR-FTPC-CY) from the HUB-100/MC-3000S

Cables connected at the wiring plate 2

- Power cable (Type: IEC60320-C13-L5M)
- LAN cable to the LAN3 port

2. WIRING

Fabricating LAN cable

Fabricate the LAN cable (FR-FTPC-CY, DTI-C5E350 VCV), as shown below. (Wrap both edges of the armor with vinyl tape.) Confirm that the shield of the cable touches to the shell of the modular plug.

Note 1: Be sure to use the shielded modular plug that is supplied with the LAN cable.

Note 2: This equipment can use either straight or crossover cables.

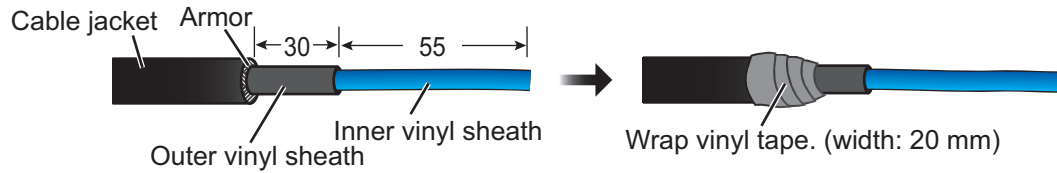

1 Expose inner vinyl sheath.



2 Remove the inner vinyl sheath by approx 25 mm. Be careful not to damage inner shield and cores.

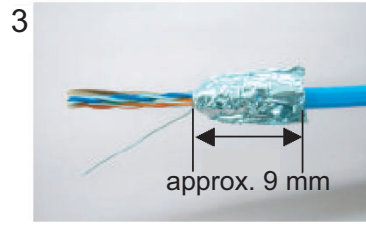

3 Fold back the shield, wrap it onto the inner vinyl sheath and cut it, leaving 9 mm.

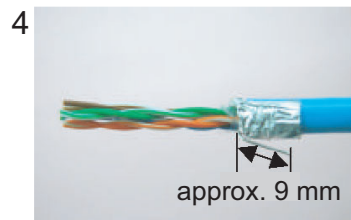

4 Fold back drain wire and cut it, leaving 9 mm.

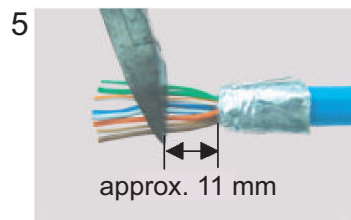

5 Straighten and flatten the cores in order and cut them, leaving 11 mm.

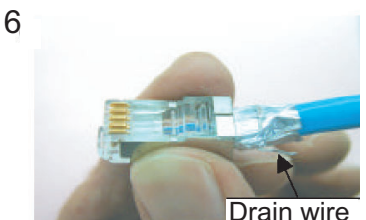

6 Insert the cable into the modular plug so that the folded part of the shield enters into the plug housing. The drain wire should be located on the tab side of the jack.



7 Using special crimping tool MPT5-8AS (PANDUIT CORP.), crimp the modular plug. Finally check the plug visually.

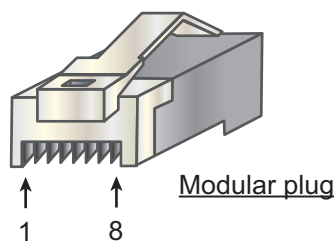

[Cross cable]

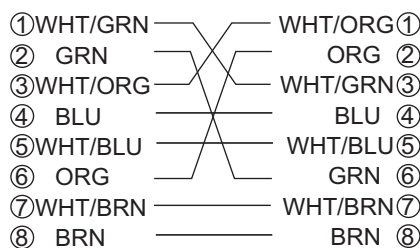

[Straight cable]

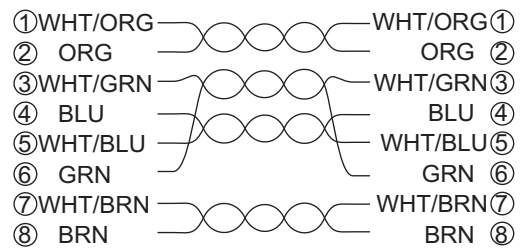

IPX2 kit

The optional IPX2 kit (Type: OP24-23, Code No.: 001-171-780) protects the connectors shown below to waterproofing standard IPX2.

Contents of IPX2 kit

Name	Type	Code No.	Qty	Remarks
Binding Screw	#4-40UNCX3/16	000-176-619-10	10	
Connector Gasket 1	24-014-0107	100-367-730-10	2	For D-sub connectors
Connector Gasket 2	24-014-0108	100-367-741-10	3	For DVI connectors
Rainproof Cover	24-014-0109	100-372-202-10	1	
Gasket Clamping Plate	24-014-0114	100-372-210-10	2	For D-sub connectors
	24-014-0115	100-372-220-10	3	For DVI connectors

1. Set the connector gasket to the unused connector not used.
2. Fasten two binding screws to fix the connector gasket.

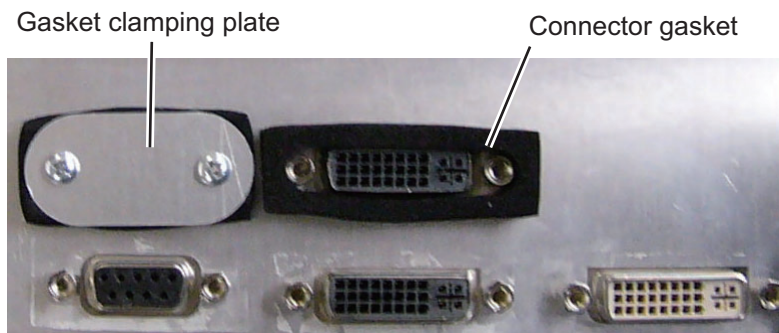

3. Peel the paper from the double-sided tape on the rainproof cover, then attach the cover to the position shown below by using four screws preattached to the processor unit.

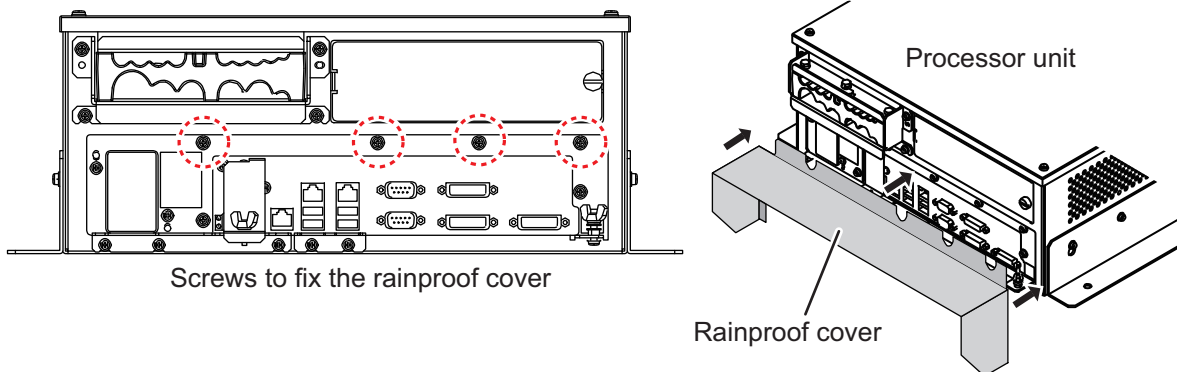

2.1.2 How to connect cables inside the processor unit

Fabrication

Fabricate JIS cables as shown below to connect them to the WAGO connectors on the I/O Board 24P0124 inside the processor unit.

For locations of cables and cores, see the sticker on the reverse side of the top cover. (All dimensions in millimeters)

Fabrication of TTYCS series

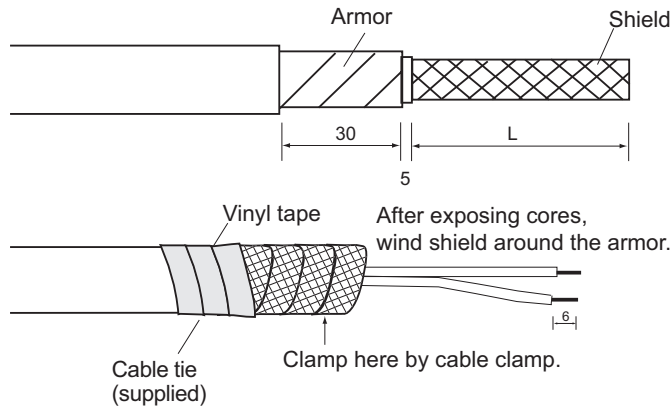

Cable type (JIS)	Length of "L"
TTYCS-4, TTYCSLA-4, TTYCS-1Q, TTYCSLA-1Q	400
TTYCS-10, TTYCSLA-10	380

Fabrication of TTYCSLA series

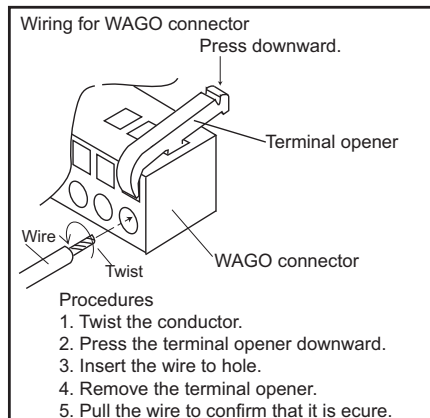
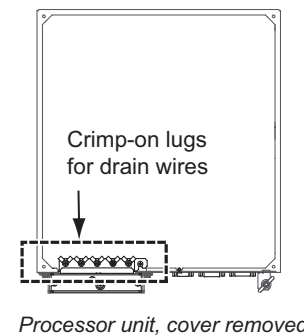
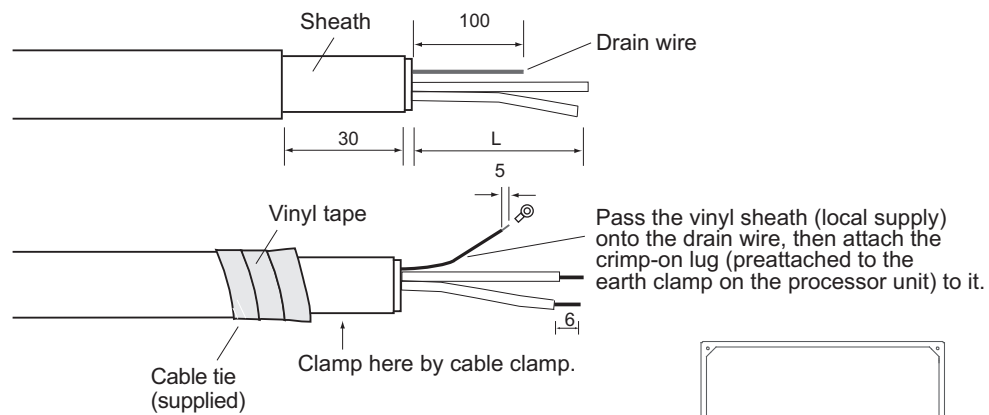

Connection

1. Unfasten four screws (M4x8) to remove the top cover from the processor unit.
2. Unfasten three bolts shown below to remove the upper plate of the cable clamp.

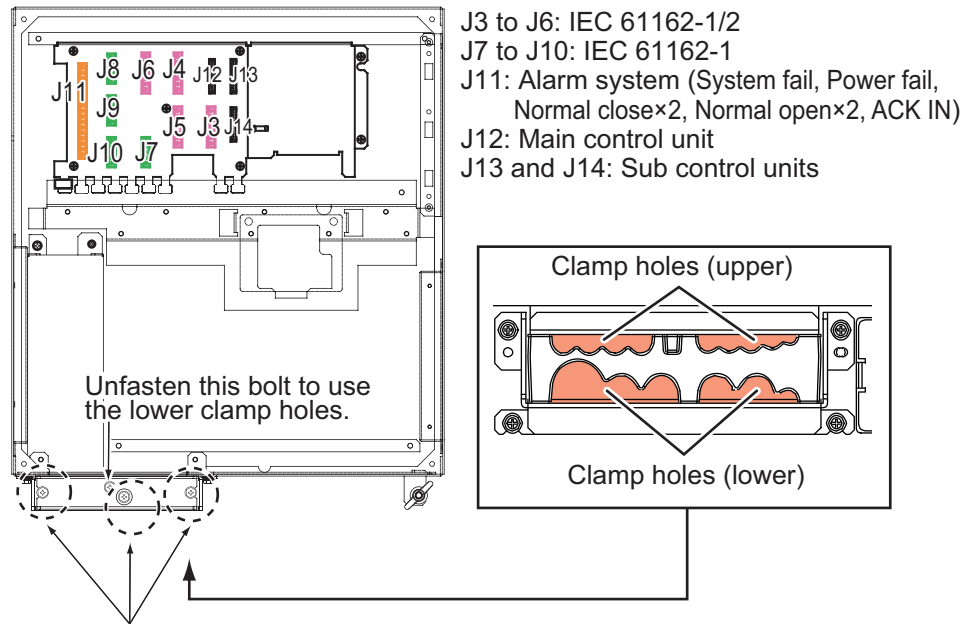

Processor unit, top view

3. Pass the cables through the clamp holes, then fasten the bolts removed at step 2 to fix the cables.



4. Connect the WAGO connectors appropriately to the I/O Board, referring to the interconnection diagram.

2. WIRING

- Bind the cables to the fixing metal in the processor unit with the cable ties (supplied).

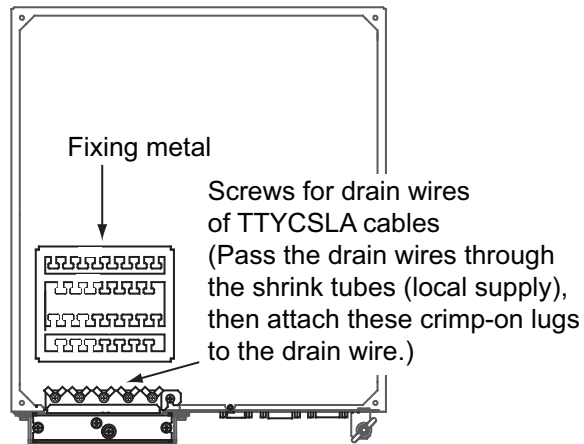

- For TTYCSLA series cables, pass the drain wire into the shrink tube (local supply), then fasten crimp-on lugs at the end of drain wires to screws shown above.

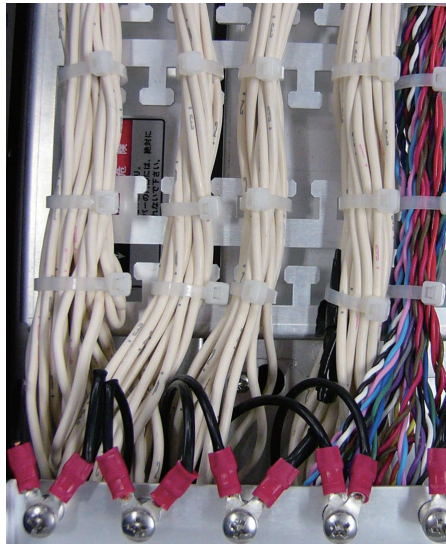

Example of wiring (inside the processor unit)

2.1.3 How to set jumper blocks on I/O Board

How to set the termination resistors

Use the jumper blocks JP1 to JP4 on the I/O Board (24P0124) to set the termination resistors for J3 to J6 ON or OFF. The default setting is ON.

- When setting the starting/ending terminal for the multipoint connection, or multipoint is not connected (CH1 to CH4): termination resistor ON
- When not setting the starting/ending terminal for the multipoint connection (CH1 to CH4): termination resistor OFF

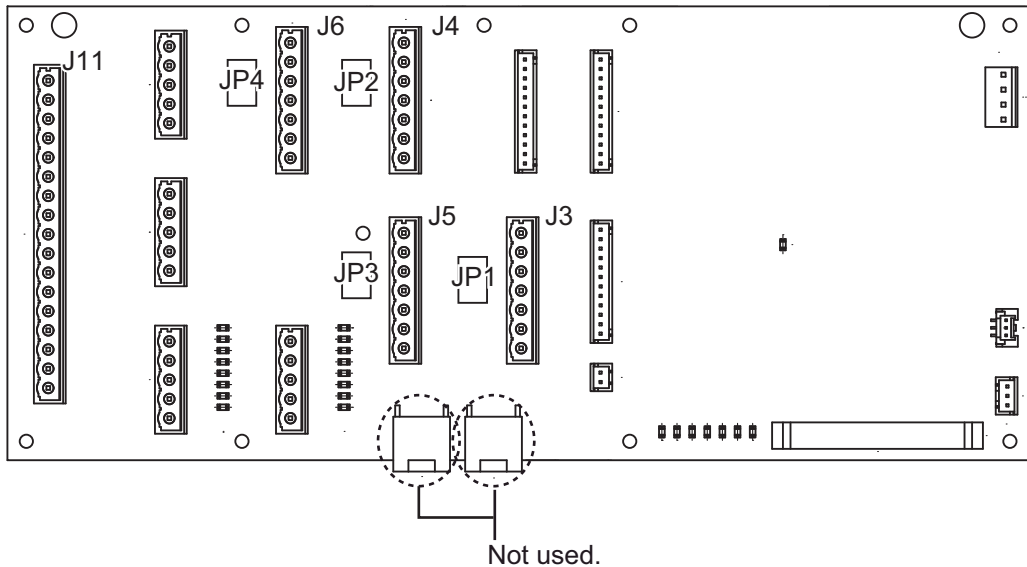

Processor unit, I/O Board (24P0124)

Jumper block JP1		Connector J3
1-2	SHORT	Termination resistor: ON (default setting)
2-3	OPEN	
1-2	OPEN	Termination connector: OFF
2-3	SHORT	

Jumper block JP2		Connector J4
1-2	SHORT	Termination resistor: ON (default setting)
2-3	OPEN	
1-2	OPEN	Termination connector: OFF
2-3	SHORT	

Jumper block JP3		Connector J5
1-2	SHORT	Termination resistor: ON (default setting)
2-3	OPEN	
1-2	OPEN	Termination connector: OFF
2-3	SHORT	

Jumper block JP4		Connector J6
1-2	SHORT	Termination resistor: ON (default setting)
2-3	OPEN	
1-2	OPEN	Termination connector: OFF
2-3	SHORT	

2. WIRING

How to select the serial input/output format

Use the connectors J3 to J6 to set the input/output format for serial CH1 to CH4, from IEC 61162-1 or IEC 61162-2. For connectors J7 to J10, use TTYCS-1Q or TTYCSLA-1Q cable for a connector.

Connector J3

Pin #	Signal	In/Out	Description	IEC 61162-2	IEC 61162-1
1	TD1-A	Out	Serial CH1, output IEC 61162-1/2	TTYCS(LA)-4	TTYCS(LA)-4
2	TD1-B	Out	Serial CH1, output IEC 61162-1/2		
3	RD1-A	In	Serial CH1, input IEC 61162-2		No connection
4	RD1-B	In	Serial CH1, input IEC 61162-2		
5	ISOGND1	-	Isolation GND (CH1)		
6	RD1-H	In	Serial CH1, input IEC 61162-1	No connection	TTYCS(LA)-4
7	RD1-C	In	Serial CH1, input IEC 61162-1		

Connector J4

Pin #	Signal	In/Out	Description	IEC 61162-2	IEC 61162-1
1	TD2-A	Out	Serial CH2, output IEC 61162-1/2	TTYCS(LA)-4	TTYCS(LA)-4
2	TD2-B	Out	Serial CH2, output IEC 61162-1/2		
3	RD2-A	In	Serial CH2, input IEC 61162-2		No connection
4	RD2-B	In	Serial CH2, input IEC 61162-2		
5	ISOGND2	-	Isolation GND (CH2)		
6	RD2-H	In	Serial CH2, input IEC 61162-1	No connection	TTYCS(LA)-4
7	RD2-C	In	Serial CH2, input IEC 61162-1		

Connector J5

Pin #	Signal	In/Out	Description	IEC 61162-2	IEC 61162-1
1	TD3-A	Out	Serial CH3, output IEC 61162-1/2	TTYCS(LA)-4	TTYCS(LA)-4
2	TD3-B	Out	Serial CH3, output IEC 61162-1/2		
3	RD3-A	In	Serial CH3, input IEC 61162-2		No connection
4	RD3-B	In	Serial CH3, input IEC 61162-2		
5	ISOGND3	-	Isolation GND (CH3)		
6	RD3-H	In	Serial CH3, input IEC 61162-1	No connection	TTYCS(LA)-4
7	RD3-C	In	Serial CH3, input IEC 61162-1		

Connector J6

Pin #	Signal	In/Out	Description	IEC 61162-2	IEC 61162-1
1	TD4-A	Out	Serial CH4, output IEC 61162-1/2	TTYCS(LA)-4	TTYCS(LA)-4
2	TD4-B	Out	Serial CH4, output IEC 61162-1/2		
3	RD4-A	In	Serial CH4, input IEC 61162-2		No connection
4	RD4-B	In	Serial CH4, input IEC 61162-2		
5	ISOGND4	-	Isolation GND (CH4)		
6	RD4-H	In	Serial CH4, input IEC 61162-1	No connection	TTYCS(LA)-4
7	RD4-C	In	Serial CH4, input IEC 61162-1		

Connector J7

Pin#	Signal	In/Out	Description	Remarks
1	TD5-A	Out	Serial CH5, output IEC 61162-1	Use TTYCS(LA)-1Q, IEC 61162-1 only
2	TD5-B	Out	Serial CH5, output IEC 61162-1	
3	RD5-H	In	Serial CH5, input IEC 61162-1	
4	RD5-C	In	Serial CH5, input IEC 61162-1	
5	GND	-	GND	

Connector J8

Pin#	Signal	In/Out	Description	Remarks
1	TD6-A	Out	Serial CH6, output IEC 61162-1	Use TTYCS(LA)-1Q, IEC 61162-1 only
2	TD6-B	Out	Serial CH6, output IEC 61162-1	
3	RD6-H	In	Serial CH6, input IEC 61162-1	
4	RD6-C	In	Serial CH6, input IEC 61162-1	
5	GND	-	GND	

Connector J9

Pin#	Signal	In/Out	Description	Remarks
1	TD7-A	Out	Serial CH7, output IEC 61162-1	Use TTYCS(LA)-1Q, IEC 61162-1 only
2	TD7-B	Out	Serial CH7, output IEC 61162-1	
3	RD7-H	In	Serial CH7, input IEC 61162-1	
4	RD7-C	In	Serial CH7, input IEC 61162-1	
5	GND	-	GND	

Connector J10

Pin#	Signal	In/Out	Description	Remarks
1	TD8-A	Out	Serial CH8, output IEC 61162-1	Use TTYCS(LA)-1Q, IEC 61162-1 only
2	TD8-B	Out	Serial CH8, output IEC 61162-1	
3	RD8-H	In	Serial CH8, input IEC 61162-1	
4	RD8-C	In	Serial CH8, input IEC 61162-1	
5	GND	-	GND	

2. WIRING

How to set contact input/output

The connector J11 can be used for the connection of contact input or voltage input. Refer to the figures shown below to make the wiring which complies with the input specification.

Note: The input must not exceed the range of the input voltage, to prevent malfunction.

-Setting for voltage input: 21.6V to 31.2V

-Setting for contact input: Voltage cannot be input (contact signal only).

- (Setting for contact input)

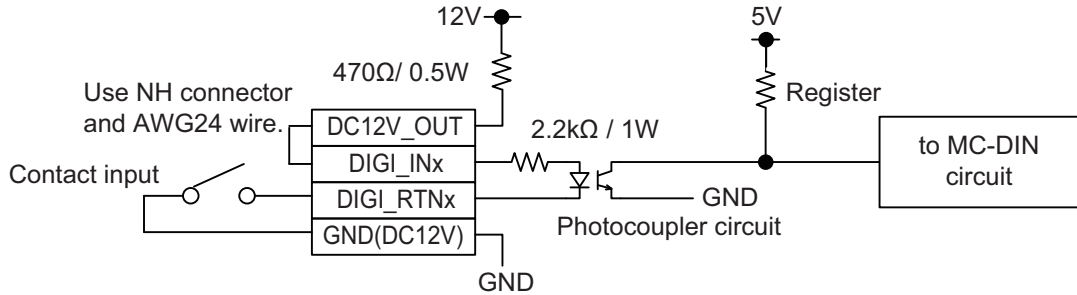

- (Setting for voltage input)

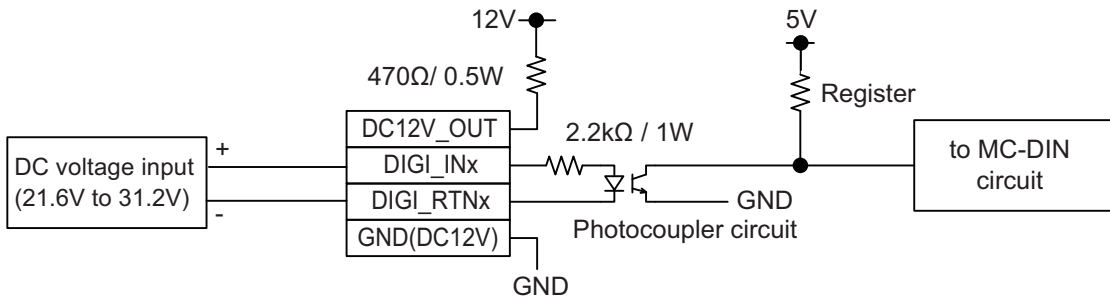

Connector J11

Pin #	Signal name	In/Out	Description	Contact input	Voltage input
1	SYS_FAIL-A	Out	System fail output (NC)	TTYCS(LA)-10	TTYCS(LA)-10
2	SYS_FAIL-B	Out	System fail output (NC)		
3	PWR_FAIL-A	Out	Power fail output (NC)		
4	PWR_FAIL-B	Out	Power fail output (NC)		
5	NC1-A	Out	Alarm output (NC1)		
6	NC1-B	Out	Alarm output (NC1)		
7	NC2-A	Out	Alarm output (NC2)		
8	NC2-B	Out	Alarm output (NC2)		
9	NO1-A	Out	Alarm output (NO1)		
10	NO1-B	Out	Alarm output (NO1)		
11	NO2-A	Out	Alarm output (NO2)		
12	NO2-B	Out	Alarm output (NO2)		
13	DC12V_OUT	Out	ACK input	#13-#14: short	No connection
14	DIGI_IN1	In	ACK input	TTYCS(LA)-10	TTYCS(LA)-10
15	DIGI_RTN1	Out	ACK input		No connection
16	GND (DC12V)	In	ACK input		No connection
17	GND	-	GND	NO connection	

Note: NC1/2 and NO1/2 are output with a fixed value.

2.2 Monitor Unit

For the wiring of the monitor unit, see the operator's manual supplied with the monitor unit.

Mounting consideration

<Standard type>

- Connect the ECDIS main monitor to the DVI1 and COM1 ports.
- For the sub ECDIS monitor, connect it to the DVI2 and COM2 port.

<Conning type>

- ECDIS main monitor: DVI1 and COM1 ports, conning monitor: DVI3 port and COM2 ports
- When an ECDIS sub monitor is added to the above connection, connect it to the DVI2 port (the brilliance adjustment is not available).

<Monitor Color Calibration>

For the following monitor, it is required to calibrate monitor color ([Monitor Color Calibration]) on the [Common Installation Settings] menu. For how to calibrate monitor color, see the instruction manual (E42-02113).

- | | | |
|---------------|---------------|---------------|
| • HD19T21 MMD | • HD24T21 MMD | • HD24T22 FUD |
| • HD26T21 MMD | • HD26T22 MMD | • HD26T22 FUD |
| • HD27T22 FUD | • HD32T22 FUD | • HD55T22 FUD |

<Notice for HD24T22 FUD-MA1-FxGx>

For the monitor unit HD24T22 FUD-MA1-FxGx, do not use the monitor cascade function (connect to the VGA Output port in the connection) as shown in the following figure. This installation is not available for the ECDIS.

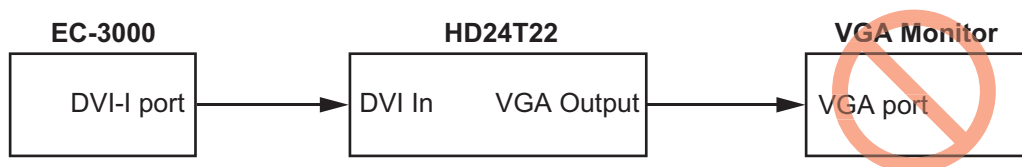

<Notice for HD55T22 FUD-MA1-FxGx>

For the monitor unit HD55T22 FUD-MA1-FxGx, attach the ferrite core (type: Wurth 742 711 31) to the optional cable DSUB9P-X2-A-L5M/10M for brilliance control.

<VDR connection>

- Do the settings in the [Common Installation Settings] menu. See the Instruction Manual (E42-02113) for the procedure.
- To connect a IEC61162-450 compliant VDR (VR-7000/S), connect the VDR to the LAN2 port.
- To connect a VDR that does not comply with IEC61162-450 (VR-3000/S), connect the VDR to the DVI3 or DVI2 port.

Connections at the EC-3000

Prepare the following cables and installation materials.

2. WIRING

- When connecting a VDR to the DVI3 port:
Use a DVI-BNCX converter cable (type: DVI-BNCX5-L2000).
- When connecting a VDR to the DVI2 port:
Use a DVI/RGB converter (maker: IMAGENICS, type: DVI-12A, local supply).

Connections at the VDR (VR-3010)

See the VDR Installation Manual.

Setting for MU-190/MU-231/MU-270W

The [INSTALLATION SETTING] menu appears only when the power is turned on for the first time after installation of the monitor unit.

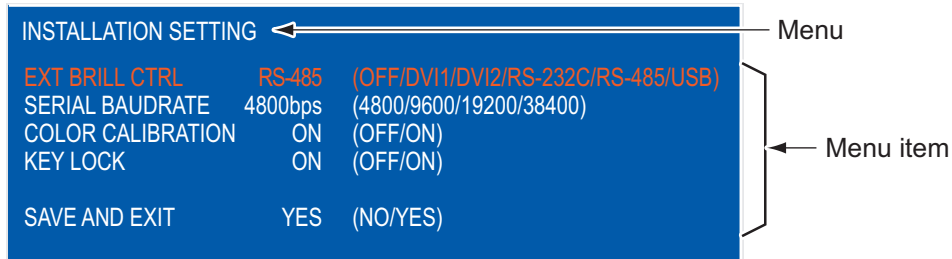

Adjust the settings referring to the following table.

EXT BRILL CTRL	SERIAL BAIDRATE	COLOR CALIBRATION	KEY LOCK	DVI PWR SYNC*
RS-485	4800bps	ON	ON	ON

*: [DVI PWR SYNC] is the slide switch at the bottom rear of the monitor unit. Confirm that this switch is set to [ON] (default setting). See “Slide switch” below for details.

Slide switch

Set the slide switch to “ON” (default setting). This setting automatically powers the monitor unit on or off according to the DVI signal input. The power switch of the monitor unit is inoperative.

Note: The OFF position provides control of the monitor unit power with the power switch of the monitor unit.

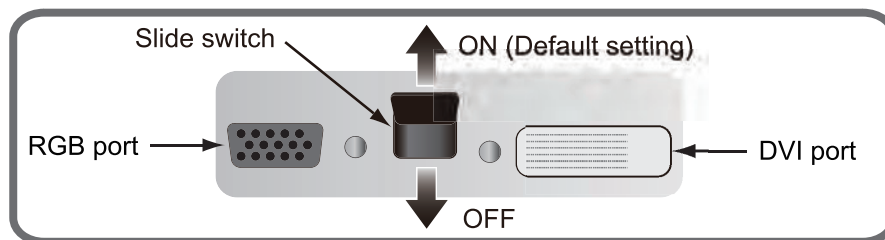

How to open the [INSTALLATION SETTING] menu

Turn off the monitor unit. While you hold the **DISP** key, press the **⏻/BRILL** key to turn on the monitor unit. Keep the **DISP** key pressed until the [INSTALLATION SETTING] menu appears.

Note: When the [DVI PWR SYNC] slide switch is ON, turn on the connected external equipment while you press the **DISP** key to turn on the monitor unit.

2.3 Sensor Adapters (option)

Maximum eight MC-3000S can be connected to a sensor network (for the redundant connection: 16). The MC-3000S (serial input/output, IEC 61162-2/1, 4ch) can connect max. 10 sensor adapters using the MC1.5-W cables. The maximum number of MC-3010A units is five.

When fabricating the MC1.5-W cables, use the lot terminal (ferrule type, supplied) to maintain performance. This fabrication requires the optional crimping tool (type: CRIMPFOX 10S). For the relations between the connectors and rod terminals, see page AP-2. Also, the stickers attached on the reverse side of the covers show the detailed connections.

Attach the cables to the applicable pins.

Pin No.	Cable color	Signal
1	Red	24V_OUT or 24V_IN
2	Black	24V_GND
3	White	MODBUS-A
4	Blue	MODBUS-B
5	Gray	GND

Use the ferrule-type terminals (supplied) to connect the cables to the terminals in the sensor adapters. This connection requires a crimping tool (CRIMPFOX10S, option).

Note 1: Use the MC1.5-W cable between the sensor adapters.

Note 2: The total length of the MC1.5-W cables should be less than 6 m to prevent malfunction.

How to attach ferrule-type lug

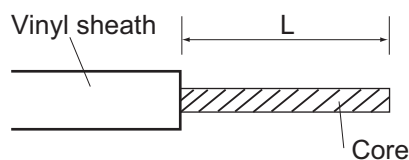

Ferrule-type lug	Length of "L"
AI 1.5-6 BK (BLK)	6 mm
AI 0.34-6 TQ (BLU)	
AI 0.75-6 GY (GREY)	
AI 1-6 RD (RED)	
AI 0.14-8 GY (GREY)	8 mm

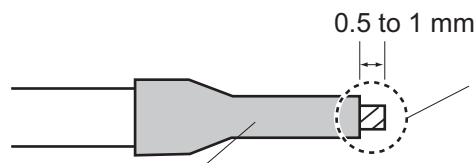

Rod terminal (ferrule type):
The core must protrude 0.5 to 1 mm past the rod terminal.

Rod terminal (ferrule type):
After attaching the rod terminal, use the optional crimping tool CRIMPFOX 10S to crimp.

2. WIRING

2.3.1 MC-3000S

Use the LAN cable FR-FTPC-CY cable to connect the MC-3000S and the processor unit. With HUB-100, a maximum of eight MC-3000S can be connected.

Fabrications

LAN cable (FR-FTPC-CY)

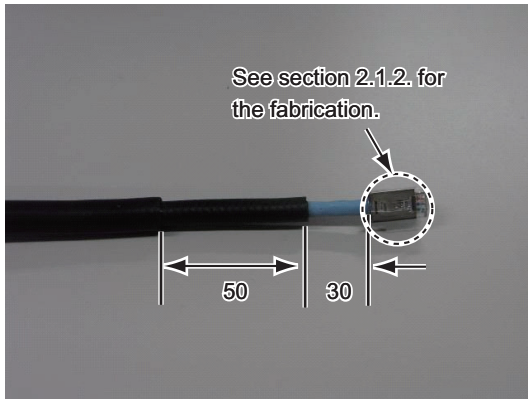

TTYCS-1Q cable

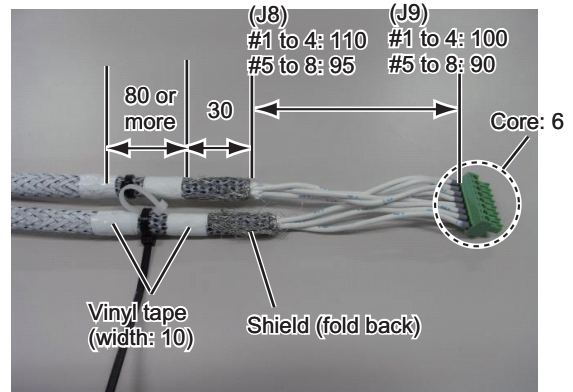

MC1.5-W-L600/1000/2000/3000 cable

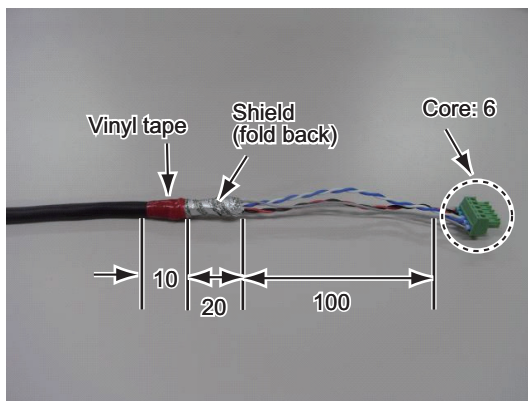

TTYCSLA-1Q cable

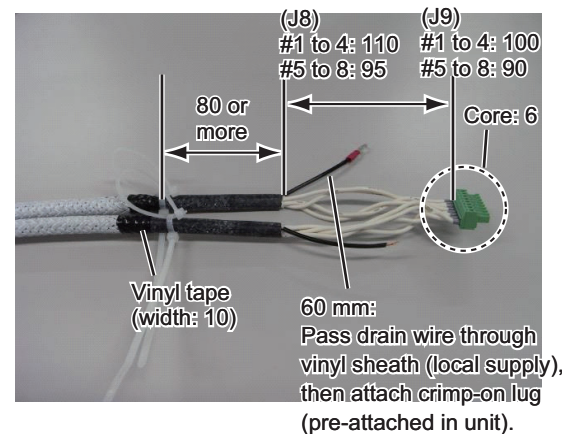

TTYCS-1 cable

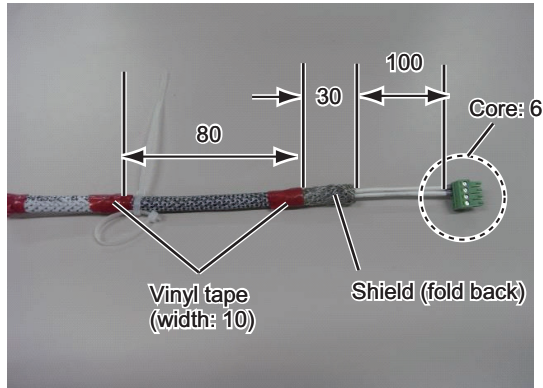

TTYCSLA-1 cable

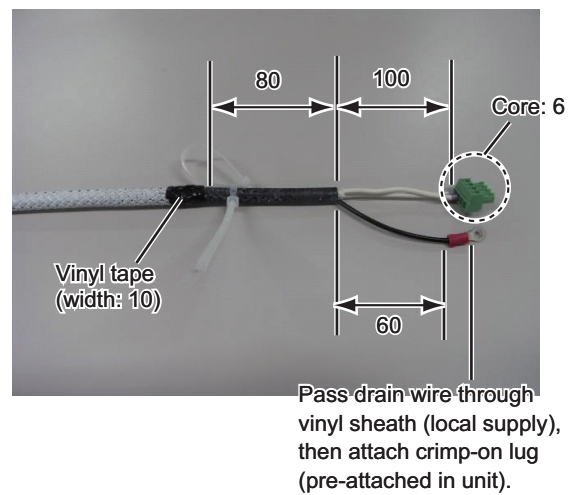

TTYCS-4 cable

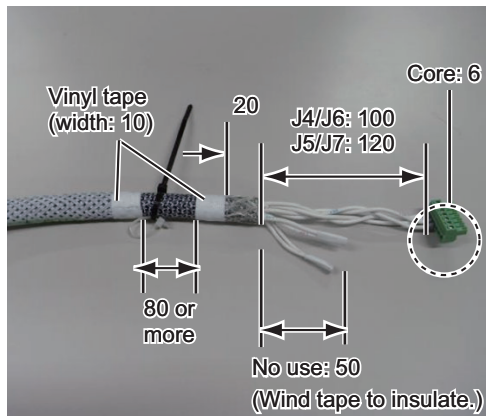

TTYCSLA-4 cable

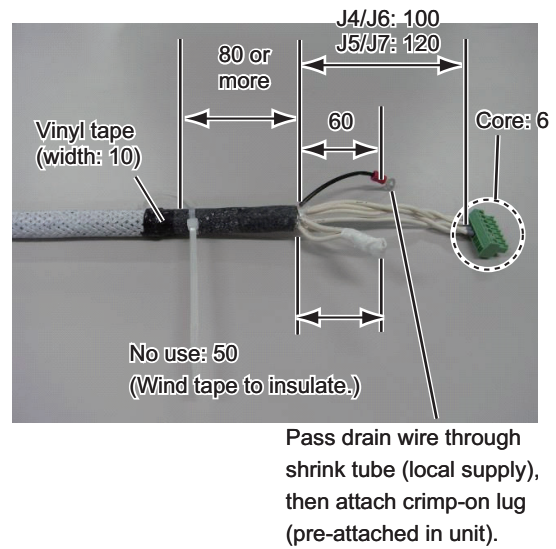

DPYC-1.5 cable

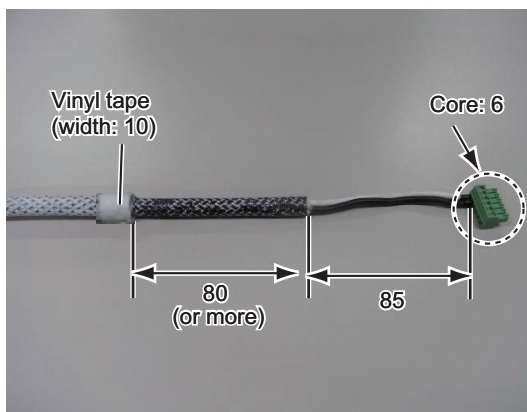

2. WIRING

Connections

Unfasten four screws to remove the cover, pass the cables through the clamps and attach the cables to respective connectors. The shield part of the cable (or drain wire) must be fastened by (connected to) the clamp.

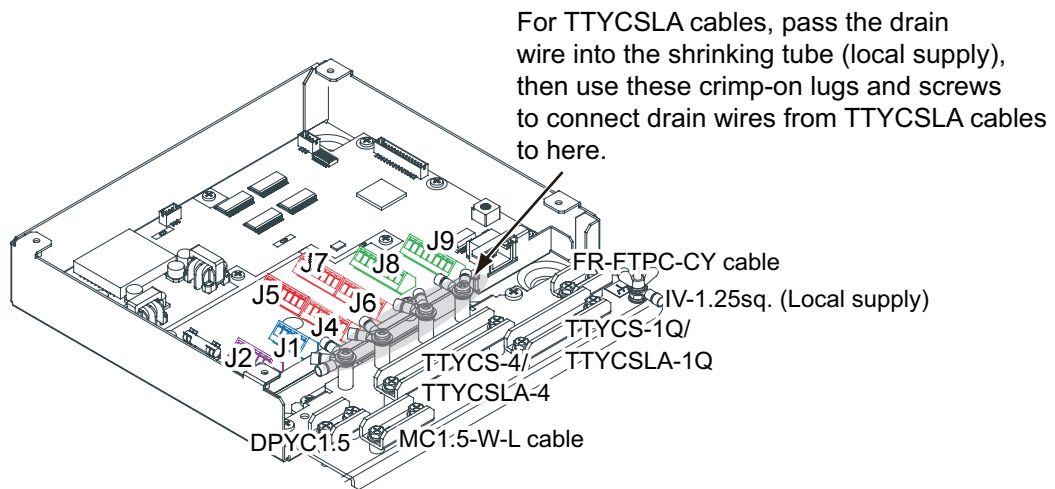

Note: Fasten the cable shield with the cable clamp.

How to set NC/NO output (J2)

The POWER FAIL signal on the connector J2 can be set to NC (normal close) output or NO (normal open) output as shown in the table below.

Connector J2

Pin #	Signal name	In/Out	Description	NO	NC
1	24V_IN	-	24 VDC	DPYC-1.5	
2	24V_GND	-	GND (24 VDC)		
3	PWR_FAIL_A	Out	Power fail output	TTYCS(LA)-1	No connection
4	PWR_FAIL_COM	Out	Power fail output		TTYCS(LA)-1
5	PWR_FAIL_B	Out	Power fail output	No connection	

How to set input specification (J4 to J9)

For connectors J4 to J7, the connections are different depending on the input specifications as shown below.

Connector J4

Pin #	Signal name	In/Out	Description	IEC 61162-2	IEC 61162-1	Modbus*		
1	TD1-A	Out	Serial CH1, output IEC 61162-1/2/modbus	TTYCS(LA)-4	TTYCS(LA)-4	TTYCS(LA)-4		
2	TD1-B	Out	Serial CH1, output IEC 61162-1/2/modbus					
3	RD1-A	In	Serial CH1, input IEC 61162-2/modbus				No connection	No connection
4	RD1-B	In	Serial CH1, input IEC 61162-2/modbus					
5	ISOGND1	-	Isolation, GND (CH1)					
6	RD1-H	In	Serial CH1, input IEC 61162-1	No connection	TTYCS(LA)-4			
7	RD1-C	In	Serial CH1, input IEC 61162-1					

*: Set the jumpers J20/J21 to Modbus.

Connector J5

Pin #	Signal name	In/Out	Description	IEC 61162-2	IEC 61162-1	Modbus*		
1	TD2-A	Out	Serial CH2, output IEC 61162-1/2/modbus	TTYCS(LA)-4	TTYCS(LA)-4	TTYCS(LA)-4		
2	TD2-B	Out	Serial CH2, output IEC 61162-1/2/modbus					
3	RD2-A	In	Serial CH2, input IEC 61162-2/modbus				No connection	No connection
4	RD2-B	In	Serial CH2, input IEC 61162-2/modbus					
5	ISOGND2	-	Isolation, GND (CH2)					
6	RD2-H	In	Serial CH2, input IEC 61162-1	No connection	TTYCS(LA)-4			
7	RD2-C	In	Serial CH2, input IEC 61162-1					

*: Set the jumpers J20/J21 to Modbus.

Connector J6

Pin #	Signal name	In/Out	Description	IEC 61162-2	IEC 61162-1	
1	TD3-A	Out	Serial CH3, output IEC 61162-1/2	TTYCS(LA)-4	TTYCS(LA)-4	
2	TD3-B	Out	Serial CH3, output IEC 61162-1/2			
3	RD3-A	In	Serial CH3, input IEC 61162-2			No connection
4	RD3-B	In	Serial CH3, input IEC 61162-2			
5	ISOGND3	-	Isolation, GND (CH3)			

2. WIRING

Pin #	Signal name	In/Out	Description	IEC 61162-2	IEC 61162-1
6	RD3-H	In	Serial CH3, input IEC 61162-1	No connection	TTYCS(LA)-4
7	RD3-C	In	Serial CH3, input IEC 61162-1		

Connector J7

Pin #	Signal name	In/Out	Description	IEC 61162-2	IEC 61162-1
1	TD4-A	Out	Serial CH4, output IEC 61162-1/2	TTYCS(LA)-4	TTYCS(LA)-4
2	TD4-B	Out	Serial CH4, output IEC 61162-1/2		
3	RD4-A	In	Serial CH4, input IEC 61162-2		No connection
4	RD4-B	In	Serial CH4, input IEC 61162-2		
5	ISOGND4	-	Isolation, GND (CH4)		
6	RD4-H	In	Serial CH4, input IEC 61162-1	No connection	TTYCS(LA)-4
7	RD4-C	In	Serial CH4, input IEC 61162-1		

Connector J8

Pin#	Signal name	In/Out	Description	Used cable
1	TD5-A	Out	Serial CH5, output IEC 61162-1	TTYCS-1Q or TTYCSLA-1Q
2	TD5-B	Out	Serial CH5, output IEC 61162-1	
3	RD5-H	In	Serial CH5, input IEC 61162-1	
4	RD5-C	In	Serial CH5, input IEC 61162-1	
5	TD6-A	Out	Serial CH6, output IEC 61162-1	
6	TD6-B	Out	Serial CH6, output IEC 61162-1	
7	RD6-H	In	Serial CH6, input IEC 61162-1	
8	RD6-C	In	Serial CH6, input IEC 61162-1	

Connector J9

Pin#	Signal name	In/Out	Description	Used cable
1	TD7-A	Out	Serial CH7, output IEC 61162-1	TTYCS-1Q or TTYCSLA-1Q
2	TD7-B	Out	Serial CH7, output IEC 61162-1	
3	RD7-H	In	Serial CH7, input IEC 61162-1	
4	RD7-C	In	Serial CH7, input IEC 61162-1	
5	TD8-A	Out	Serial CH8, output IEC 61162-1	
6	TD8-B	Out	Serial CH8, output IEC 61162-1	
7	RD8-H	In	Serial CH8, input IEC 61162-1	
8	RD8-C	In	Serial CH8, input IEC 61162-1	

Case packing OP24-28

The optional kit OP24-28 protects the connectors on the MC-3000S to waterproofing standard IPX2.

Case packing (type: OP24-28, code no.: 001-169-970)

Name	Type	Code No.	Qty	Remarks
Case packing (serial)	24-014-2051	100-367-880-10	2	For MC-3000S

1. Unfasten four binding screws to remove the cover from the adapter.

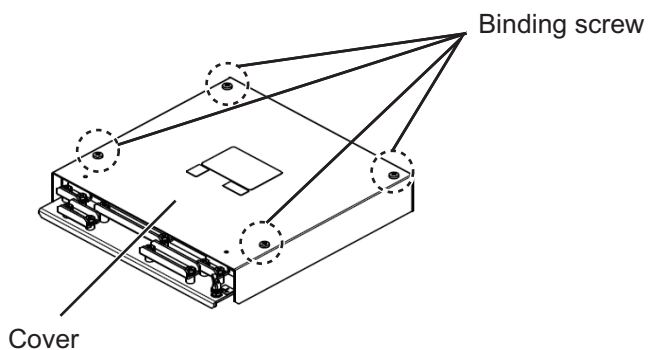

2. Peel the paper from the case packing, then attach the case packing to the reverse side of the cover and the body unit as shown below.

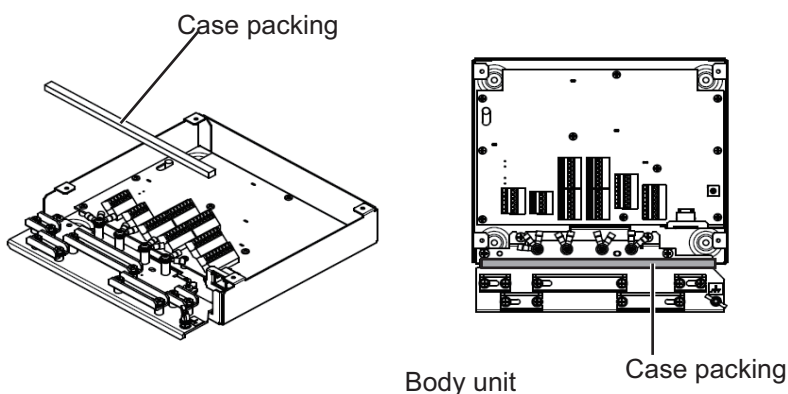
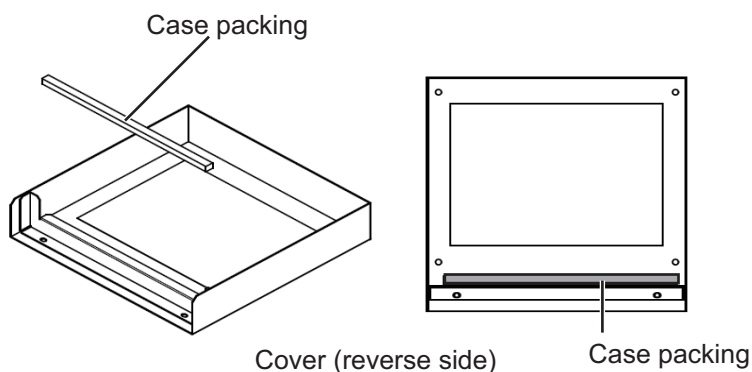

3. Attach the cover to the MC-3000S body unit.

2.3.2 MC-3010A/3020D/3030D

- MC-3010A: Inputs analog signal. To set MC-3010A to the current input, connect short pins to each terminals.
- MC-3020D: Inputs digital signal (8ch contact input). Contact or voltage input is selectable (contact input requires short pins).
- MC-3030D: Outputs digital signal (8ch, normal open/close).

Fabrications

MC1.5-W-L600/1000/2000/3000 cable (Input)

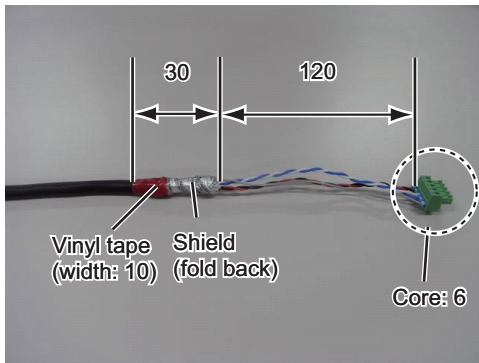

TTYCSLA-1 (MC-3010A)

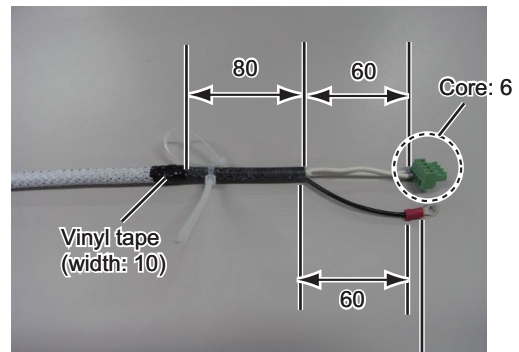

Pass drain wire through shrink tube (local supply), then attach crimp-on lug (pre-attached in unit).

MC1.5-W-L600/1000/2000/3000 cable (Output)

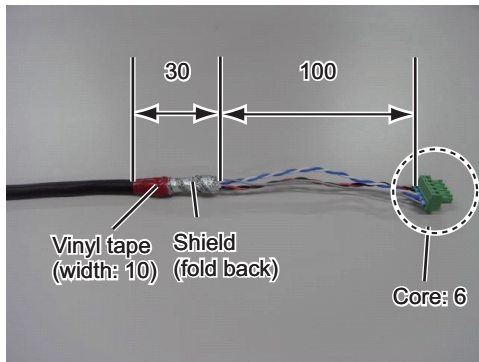

TTYCS-1 (MC-3010A)

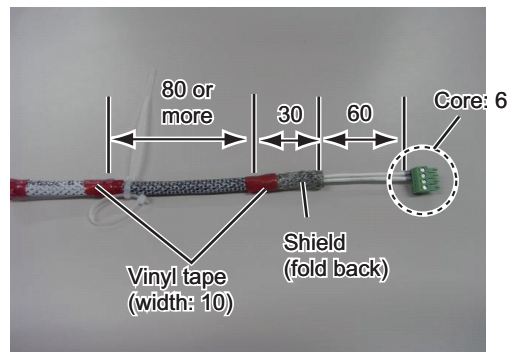

MPYC-12 cable (MC-3030D)

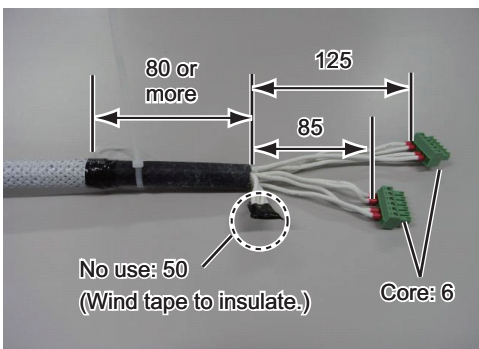

MPYC-12 cable (MC-3020D)

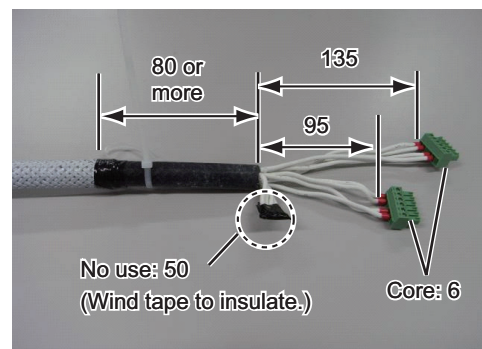

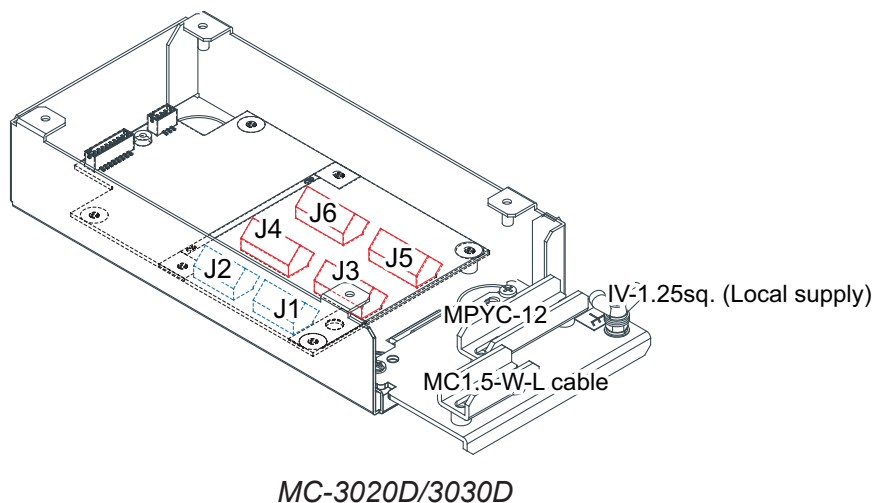
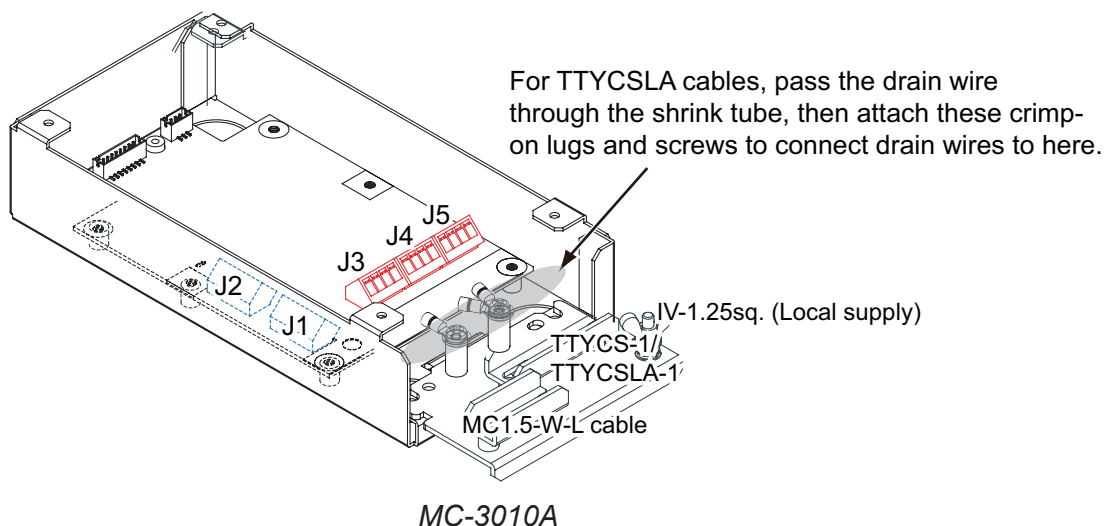
Connection

Note: Fasten the cable shield with the cable clamp.

Input method (MC-3010A only)

Select the method of the analog data input, power voltage or power current.

Note 1: The input must not exceed the range of the input voltage, to prevent malfunction.

-Setting for voltage input: -10V to +10V or 0 to 10V (depending on the setting)

-Setting for contact input: Voltage 4mA to 20mA.

Note 2: When changing the input method, turn off the MC-3010A and on again to put change in effect.

2. WIRING

- Power voltage: Input the amount of power voltage change to the operational amplifier.

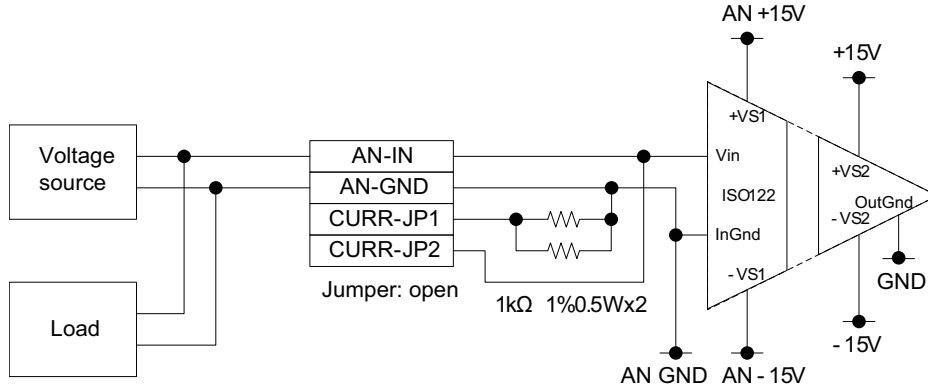

- Power current: Pass the power current to the shunt resistor, 1kΩ/parallel (combined resistance: 500Ω) to input the amount of voltage change at the both ends of the resistor to the operational amplifier.

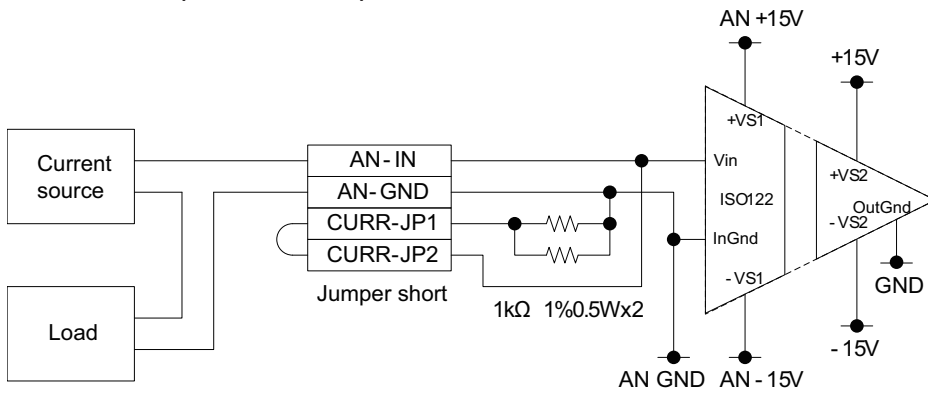

Connector J3

Pin #	Signal name	In/Out	Description	Power voltage	Power current
1	AN1_IN	In	Analog 1 input	TTYCS(LA)-1	
2	AN1_GND	-	Analog 1 GND		
3	CURR1_JP1	-	Analog 1 input, power current/voltage setting jumper 1	Pin #3-#4: open	Pin #3-#4: short
4	CURR1_JP2	-	Analog 2 input, power current/voltage setting jumper 1		

Connector J4

Pin #	Signal name	In/Out	Description	Power voltage	Power current
1	AN2_IN	In	Analog 2 input	TTYCS(LA)-1	
2	AN2_GND	-	Analog 2 GND		
3	CURR2_JP1	-	Analog 2 input, power current/voltage setting jumper 1	Pin #3-#4: open	Pin #3-#4: short
4	CURR2_JP2	-	Analog 2 input, power current/voltage setting jumper 1		

Connector J5

Pin #	Signal name	In/Out	Description	Power voltage	Power current
1	AN3_IN	In	Analog 3 input	TTYCS(LA)-1	
2	AN3_GND	-	Analog 3 GND		
3	CURR3_JP1	-	Analog 3 input, power current/voltage setting jumper 1	Pin #3-#4: open	Pin #3-#4: short
4	CURR3_JP2	-	Analog 3 input, power current/voltage setting jumper 1		

How to set ACK input (MC-3020D)

Use the connectors J3 to J6 on the MC-DIN Board (24P0116) to set the ACK input for ACK1 to ACK8 as shown below.

- Input circuit for voltage input

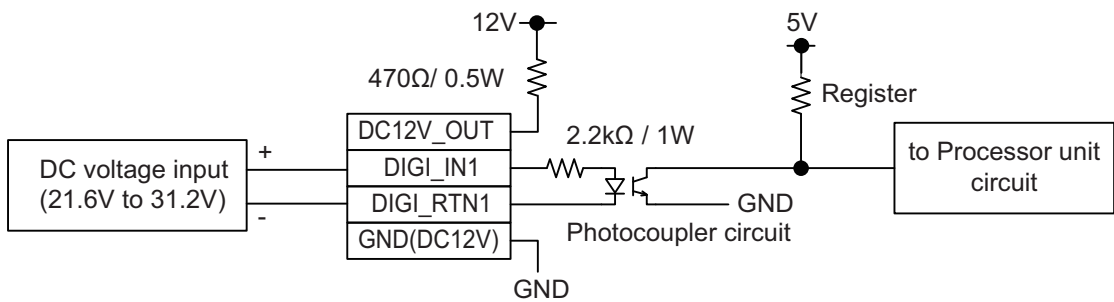

- Input circuit for contact input

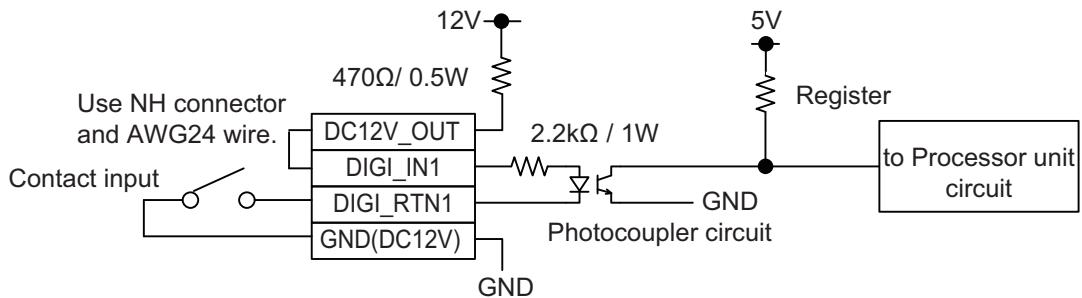

Note 1: The input must not exceed the range of the input voltage, to prevent malfunction.

-Setting for voltage input: 21.6 V to 31.2 V

-Setting for contact input: Voltage cannot be input (contact signal only).

Note 2: For analog input, see page 2-23

2. WIRING

Connector J3

Pin #	Signal name	In/Out	Remarks	ACK1 contact	ACK1 voltage	ACK2 contact	ACK2 voltage
1	DC12V_OUT	Out	ACK1 In	Pin #1-#2: short MPYC-12	No connection		-
2	DIGI_IN1	In			MPYC-12		
3	DIGI_RTN1	Out					
4	GND (DC12V)	In			No connection		
5	DC12V_OUT	Out	ACK2 In		-	Pin #5-#6: short	No connection
6	DIGI_IN2	In				MPYC-12	MPYC-12
7	DIGI_RTN2	Out					
8	GND (DC12V)	In					NO connection

Connector J4

Pin #	Signal name	In/Out	Remarks	ACK3 contact	ACK3 voltage	ACK4 contact	ACK4 voltage
1	DC12V_OUT	Out	ACK3 In	Pin #1-#2: short MPYC-12	No connection		-
2	DIGI_IN3	In			MPYC-12		
3	DIGI_RTN3	Out					
4	GND (DC12V)	In			No connection		
5	DC12V_OUT	Out	ACK4 In		-	Pin #5-#6: short	No connection
6	DIGI_IN4	In				MPYC-12	MPYC-12
7	DIGI_RTN4	Out					
8	GND (DC12V)	In					No connection

Connector J5

Pin #	Signal name	In/Out	Remarks	ACK5 contact	ACK5 voltage	ACK6 contact	ACK6 voltage
1	DC12V_OUT	Out	ACK5 In	Pin #1-#2: short MPYC-12	No connection		-
2	DIGI_IN5	In			MPYC-12		
3	DIGI_RTN5	Out					
4	GND (DC12V)	In			No connection		
5	DC12V_OUT	Out	ACK6 In		-	Pin #5-#6: short	No connection
6	DIGI_IN6	In				MPYC-12	MPYC-12
7	DIGI_RTN6	Out					
8	GND (DC12V)	In					No connection

Connector J6

Pin #	Signal name	In/Out	Remarks	ACK7 contact	ACK7 voltage	ACK8 contact	ACK8 voltage
1	DC12V_OUT	Out	ACK7 In	Pin #1-#2: short MPYC-12	No connection		-
2	DIGI_IN7	In			MPYC-12		
3	DIGI_RTN7	Out					
4	GND (DC12V)	In			No connection		
5	DC12V_OUT	Out	ACK8 In		-	Pin #5-#6: short	No connection
6	DIGI_IN8	In				MPYC-12	MPYC-12
7	DIGI_RTN8	Out					
8	GND (DC12V)	In					No connection

How to set alarm output (MC-3030D)

Use the connector J3 to J6 on the MC_OUT Board (24P0117) to select NC (normal close) or NO (normal open) for alarm output 1 to 8.

Connector J3

Pin #	Signal name	In/Out	Remarks	Alarm1 NO Out	Alarm1 NC Out	Alarm2 NO Out	Alarm2 NC Out
1	A1	Out	Alarm1 Out	MPYC-12	No connection	-	
2	COM1				MPYC-12		
3	B1			No connection			
4	A2		Alarm2 Out	-		MPYC-12	No connection
5	COM2					MPYC-12	
6	B2				No connection		

Connector J4S

Pin #	Signal name	In/Out	Remarks	Alarm3 NO Out	Alarm3 NC Out	Alarm4 NO Out	Alarm4 NC Out
1	A3	Out	Alarm3 Out	MPYC-12	No connection	-	
2	COM3				MPYC-12		
3	B3			No connection			
4	A4		Alarm4 Out	-		MPYC-12	No connection
5	COM4					MPYC-12	
6	B4				No connection		

Connector J5

Pin #	Signal name	In/Out	Remarks	Alarm5 NO Out	Alarm5 NC Out	Alarm6 NO Out	Alarm6 NC Out
1	A5	Out	Alarm5 Out	MPYC-12	No connection	-	
2	COM5				MPYC-12		
3	B5			No connection			
4	A6		Alarm5 Out	-		MPYC-12	No connection
5	COM6					MPYC-12	
6	B6				No connection		

Connector J6

Pin #	Signal name	In/Out	Remarks	Alarm7 NO Out	Alarm7 NC Out	Alarm8 NO Out	Alarm8 NC Out
1	A7	Out	Alarm7 Out	MPYC-12	No connection	-	
2	COM7				MPYC-12		
3	B7			No connection			
4	A8		Alarm8 Out	-		MPYC-12	No connection
5	COM8					MPYC-12	
6	B8				No connection		

Case packing OP24-29

The optional kit OP24-29 protects the connectors on the MC-3010A/3020D/3030D to waterproofing standard IPX2.

Case packing (type: OP24-29, code no.: 001-169-960)

Name	Type	Code No.	Qty	Remarks
Case packing (analog)	24-014-2052-1	100-367-961-10	2	MC-3010A/3020D/3030D

1. Unfasten four binding screws to remove the cover from the adapter.

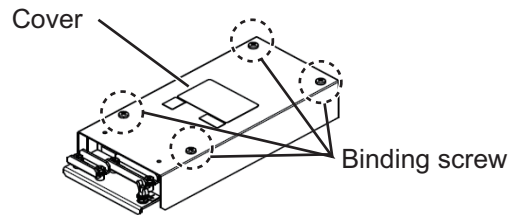

2. Peel the paper from the case packing, then attach the case packing to the reverse side of the cover and the body unit as shown below.

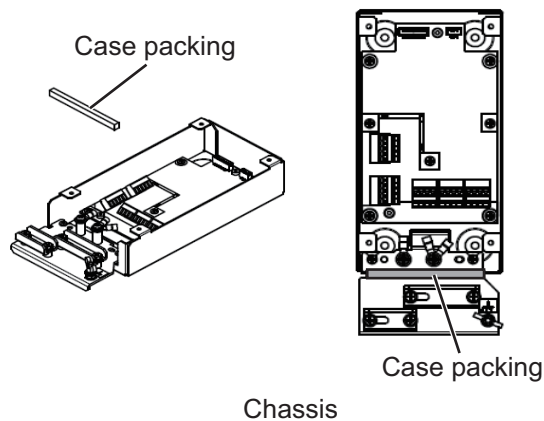
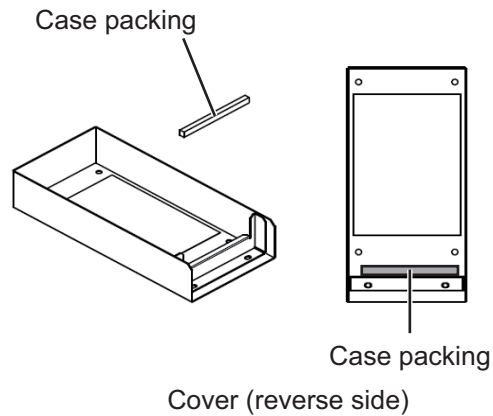

3. Attach the cover to the MC-3010A/3020D/3030D chassis.

2.3.3 How to set jumper blocks in the sensor adapters

MC-3000S

Set the jumper blocks in the MC-CS Board (24P0114) referring to the tables that follow.

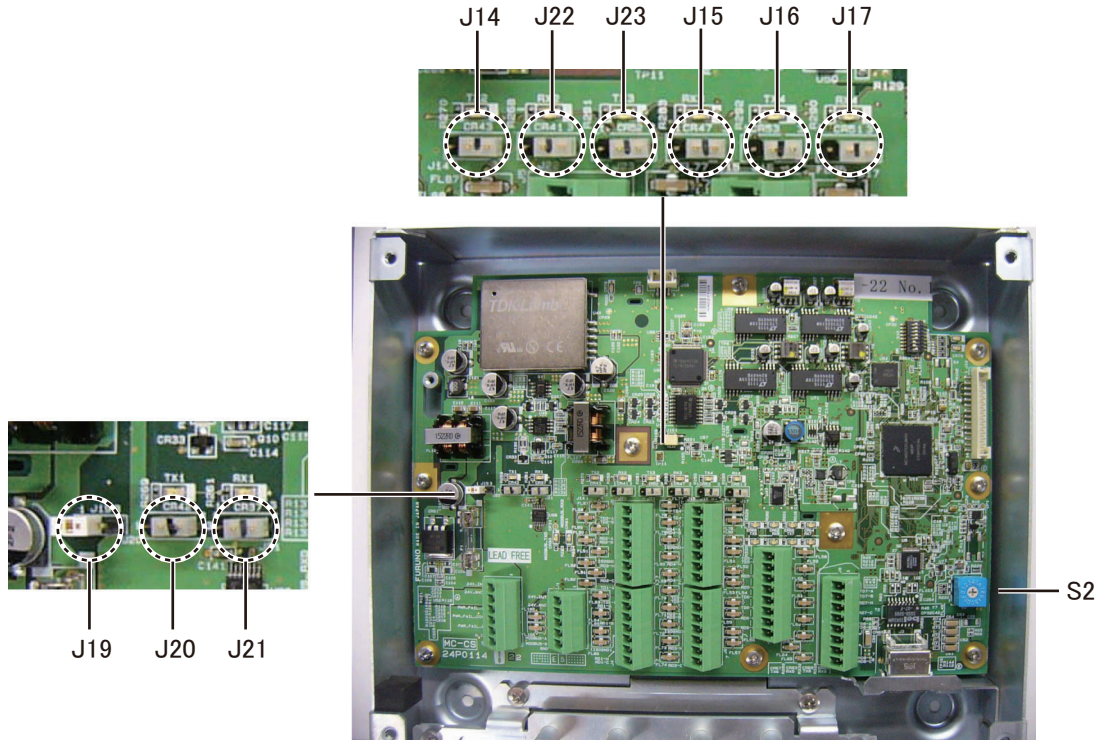

MC-CS Board (24P0114)

Rotary switch: Use the rotary switch (S2) to set the Modbus address when setting connectors J4/J5 to Modbus. The Modbus address set at J4/J5 in the network is not used. When setting J4/J5 to IEC 61162-1/2, use the default setting (“0”).

Jumper block:

Use the jumper block J19 to set the termination resistor on/off for the MODBUS communication on the connector J1. For the first and last sensor adapter in a series, their termination resistors should be set to ON. Use the MC-CS Board with the default setting because it becomes the “first” adapter in a series.

Jumper block J19		Connector J1
1-2	SHORT	Termination resistor: ON (default setting)
2-3	OPEN	
1-2	OPEN	Termination resistor: OFF
2-3	SHORT	

Set the jumper blocks J14 through J17 to turn the termination resistors on connectors J4 through J7 respectively.

(Termination resistor ON)

- When setting the starting/ending terminal for the multipoint, or the multipoint is not connected (CH1 to 4).
- When setting the starting/ending terminal for Modbus (CH1, CH2)

2. WIRING

(Terminal resistor OFF)

- When setting the terminal other than starting/ending for the multipoint (CH1 to 4).
- When setting the terminal other than starting/ending for Modbus (CH1/CH2)

Jumper block J14		Connector J4 (CH1)
1-2	SHORT	Termination resistor: ON (default setting)
2-3	OPEN	
1-2	OPEN	Termination resistor: OFF
2-3	SHORT	

Jumper block J15		Connector J5 (CH2)
1-2	SHORT	Termination resistor: ON (default setting)
2-3	OPEN	
1-2	OPEN	Termination resistor: OFF
2-3	SHORT	

Jumper block J16		Connector J6 (CH3)
1-2	SHORT	Termination resistor: ON (default setting)
2-3	OPEN	
1-2	OPEN	Termination resistor: OFF
2-3	SHORT	

Jumper block J17		Connector J7 (CH4)
1-2	SHORT	Termination resistor: ON (default setting)
2-3	OPEN	
1-2	OPEN	Termination resistor: OFF
2-3	SHORT	

Set the jumper blocks J20 and J21 to choose the communication type (IEC-61162-1/2 or MODBUS) of the connector J4 (CH1).

The setting of the jumper block JP20 and JP21 must be identical.

Jumper block J20/J21		Communication type of J4 (between RD1 and TD1)
1-2	OPEN	IEC-61162-1/2 (default setting)
2-3	SHORT	
1-2	SHORT	MODBUS (The setting of J14 is different depending on the unit position (starting/ending terminal).)
2-3	OPEN	

The jumper blocks J22 and J23 are used to set the communication type of the connector J5 (CH2).

Jumper block J22/J23		Communication type of J5 (between RD2 and TD2)
1-2	OPEN	IEC-61162-1/2 (default setting)
2-3	SHORT	
1-2	SHORT	MODBUS (The setting of J15 is different depending on the unit position (starting/ending terminal).)
2-3	OPEN	

MC-3010A/3020D/3030D

This paragraph shows how to set the MC-ANLG Board (24P0115, for MC-3010A), MC-DIN Board (24P0116, for MC-3020D) and MC-DOUT Board (24P0117, for MC-3030D).

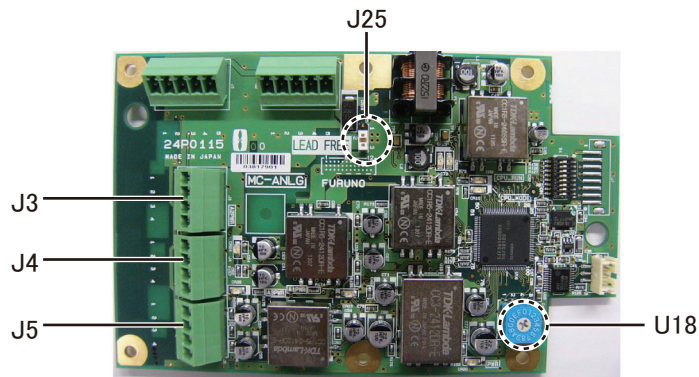

MC-ANLG Board (24P0115)

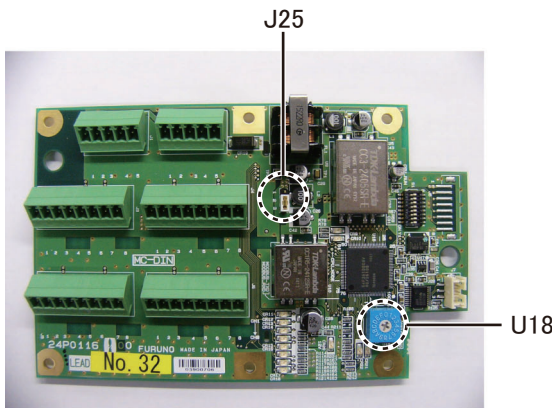

MC-DIN Board (24P0116)

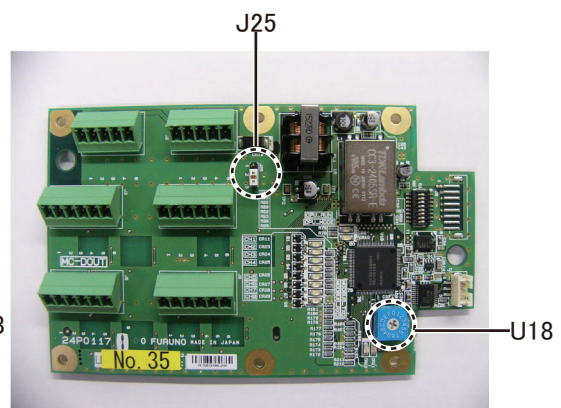

MC-DOUT Board (24P0117)

Rotary switch: Use the rotary switch (U18) to set the MODBUS address with a digit of number from “0”. When multiple sensor adapters are connected to the MC-3000S, the same number cannot be used among them. (It is allowed to use the same number between the MC-3000S and a sensor adapter.)

Jumper block

Use the jumper block J25 to set the termination resistor on/off for the MODBUS communication on the connector J1. For the first and last sensor adapter in a series, their termination resistors should be set to ON. If not, communication between sensor adapters is not possible.

Jumper block J25		Connector J1
1-2	OPEN	Termination resistor: OFF (default setting)
2-3	SHORT	
1-2	SHORT	Termination resistor: ON
2-3	OPEN	

2.4 Intelligent HUB (option)

Fix the LAN cable connected to the cable clamp using the cable ties (supplied).

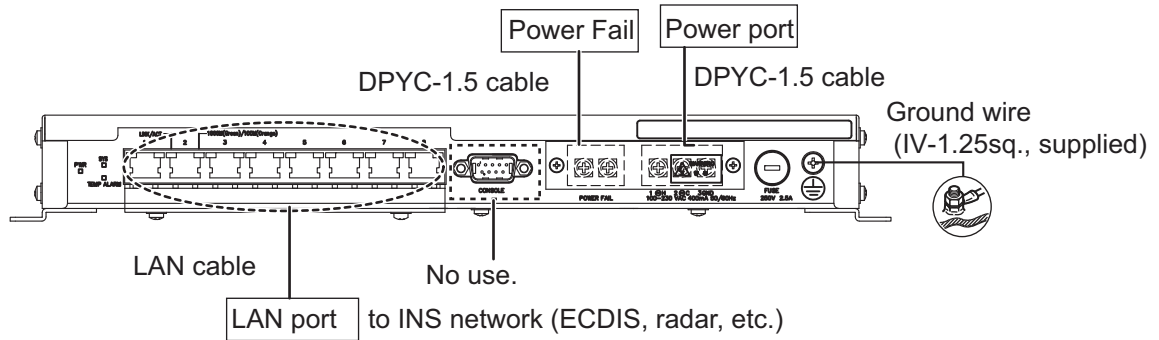

Attach the LAN cap (supplied) to the unused connector holes to provide waterproofing standard IPX2.

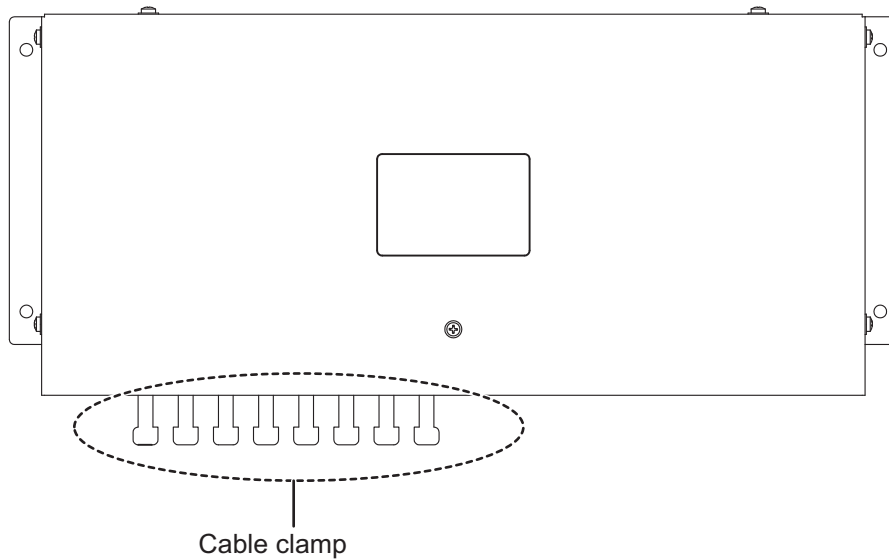

2.5 How to Extend the Control Unit Cable (option)

To extend the length of the cable between the control unit and the processor unit, use the appropriate cable assembly for the control unit, as listed below.

- RCU-024: TET-16-045A (5/10/20/30 m)
- RCU-026: 6TPSH-XH12X2-LxxSP2 (5/10/20/30 m)

Note: When the control unit cable is 10 m or longer, the USB cable (TS-20-071-1, 5 m) that is supplied with the control unit cannot be used. Even if the USB cable is not used, you can operate the control unit properly, but the USB port on the control unit is deactivated.

2.5.1 ECDIS control unit (RCU-024)

Wiring for the control unit

1. Unfasten 12 binding screws (M3x8) from the bottom of the control unit to remove the cover.

Note: Do not add stress to the cables connected to the control unit board when removing the cover. When the serial number of the control unit is "200001" or later, disconnect the cable from the J3 (see the figure on step 3) before removing the cover.

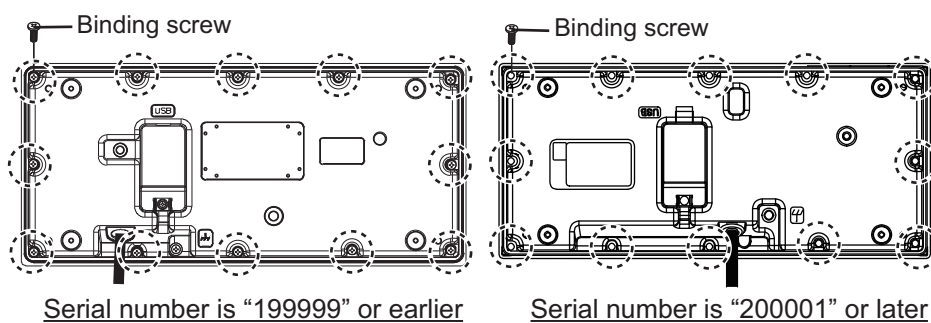

2. Unfasten two screws to remove the cable clamp.
3. Release the control unit cable from the wiring clamp, then disconnect the cable from the J1.

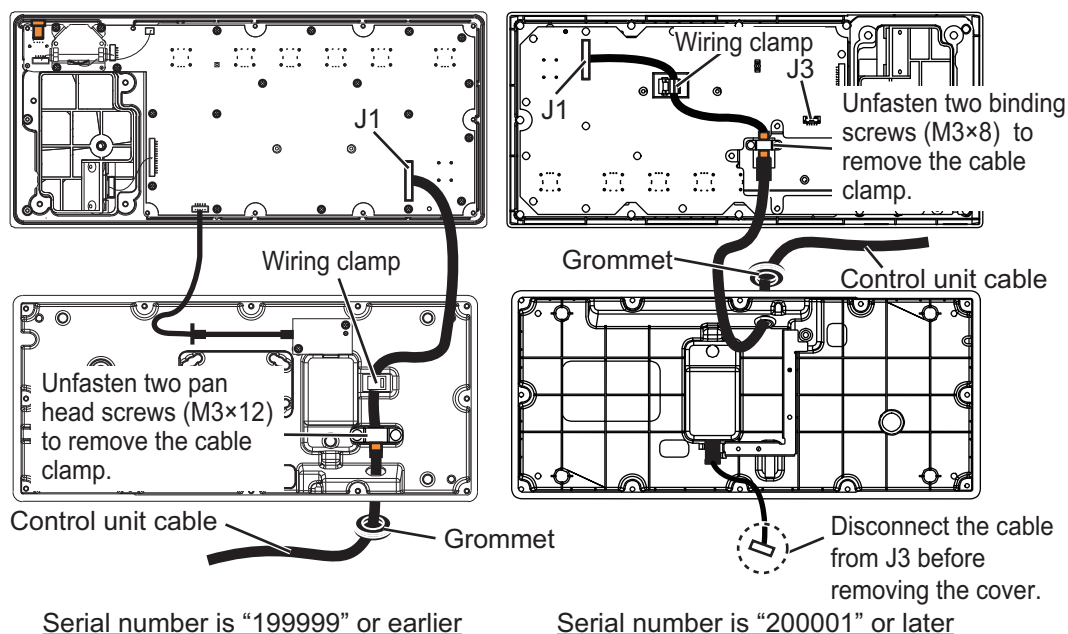

2. WIRING

4. Pull out the control unit cable from the cover.
5. Pass the optional cable assy (TET-16-045A) through the grommet and cable entrance on the control unit.
6. Fasten the shield of the cable with the cable clamp (removed at step 2).
Note: When the serial number is “200001” or later, fasten the shield as shown in the figure to the right.

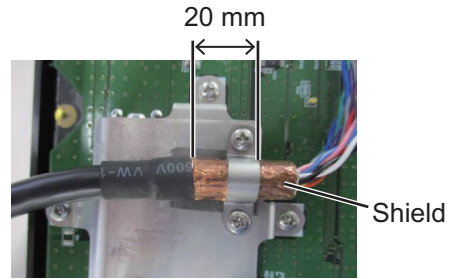

7. Connect the cable to the J1, then secure the cable with the wiring clamp.
8. Reattach the control unit cover.

Wiring for the processor unit

1. Unfasten four screws (M4x8) to remove the processor unit cover.
2. Unfasten three bolts to remove the cable clamp (upper) as shown below.

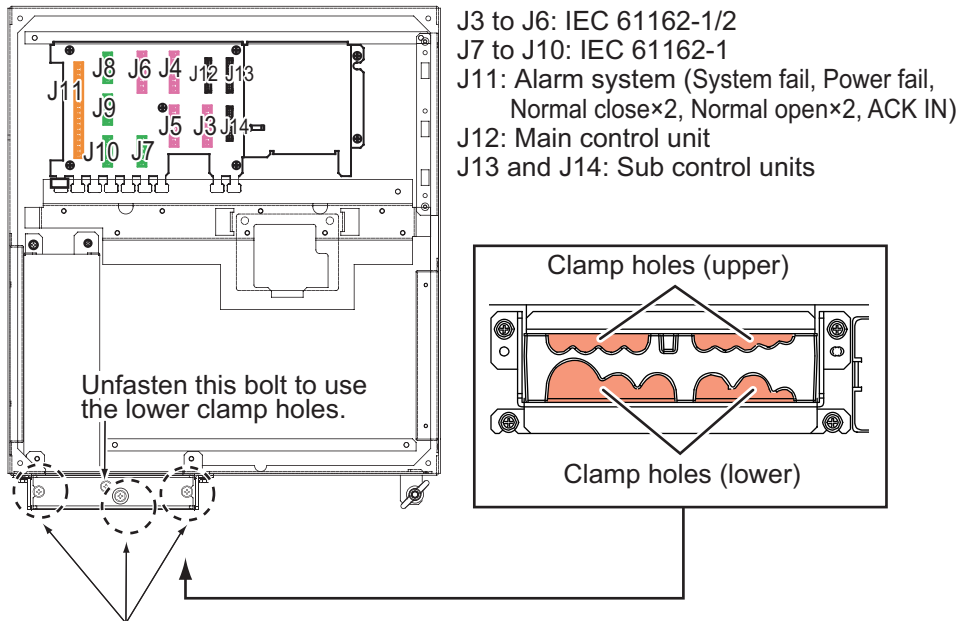

3. Unfasten these three bolts to remove the upper plate.
4. Disconnect the control unit cable from the processor unit, then connect the cable assy (TET-16-045A).
5. Set the shield part of cables under the cable clamp then tighten the cable clamp.

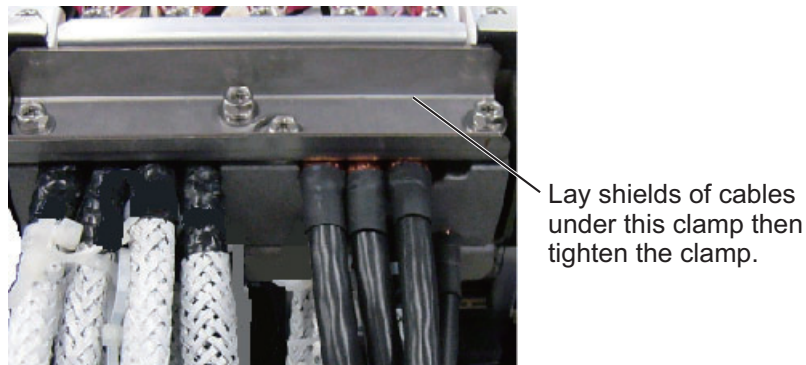

6. Attach the processor unit cover.

2.5.2 Trackball control unit (RCU-026)

Wiring for the trackball control unit

1. Unfasten four binding screws (M3x8) from the bottom of the control unit, and a pan head screw (M3x8) and flat washer from the back of the control unit to remove the cover.

Note: Be careful not to add stress to the cables connected to the control unit board when removing the cover.

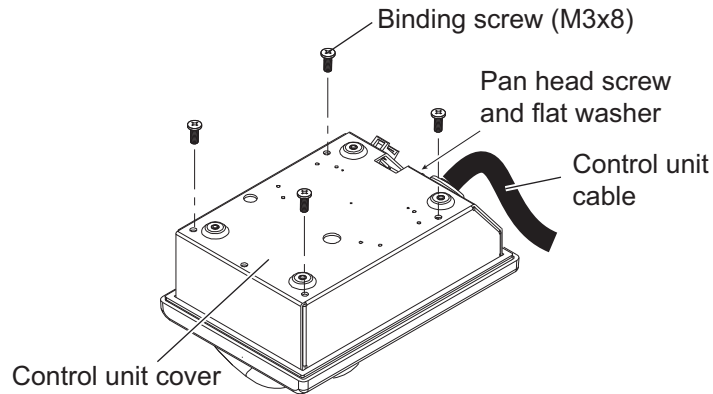

2. Remove the cable clamp from the control unit, then disconnect the control unit cable from the J1 connector.

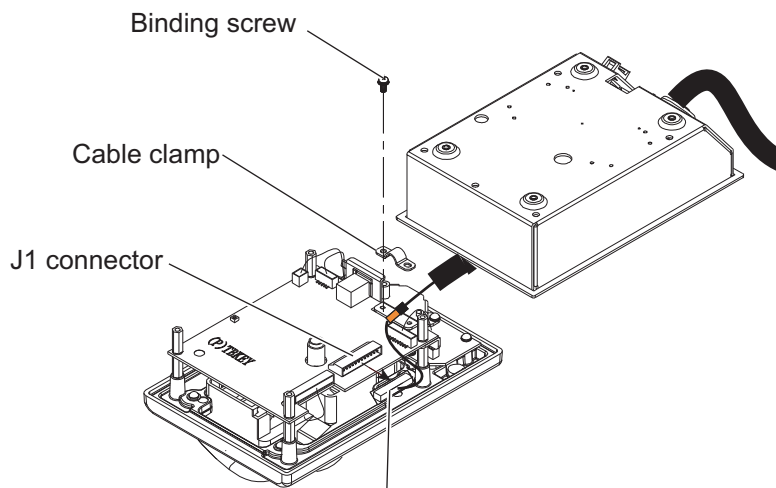

3. Pull out the control unit cable from the cover.
4. Pass the optional cable assy (6TPSH-XH12X2-LxxSP2) through the cable hole on the cover.

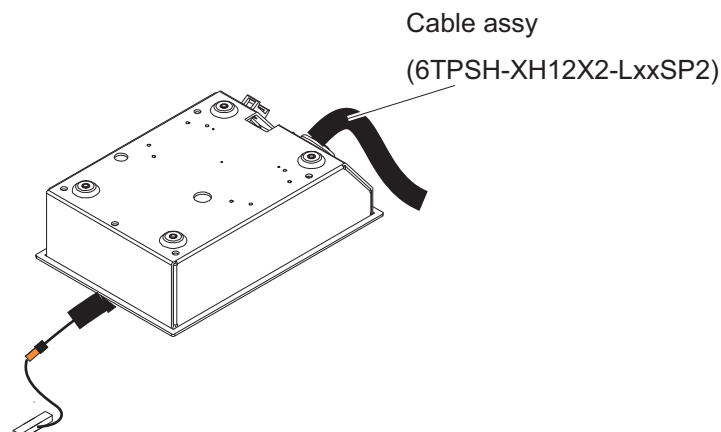

2. WIRING

- Fasten the shield part of the cable assy with the cable clamp (removed at step 2), then connect the connector at the end of the cable assy to the J1 on the control unit board.

Note: When clamping, the shield part of the cable must not touch the circuit board.

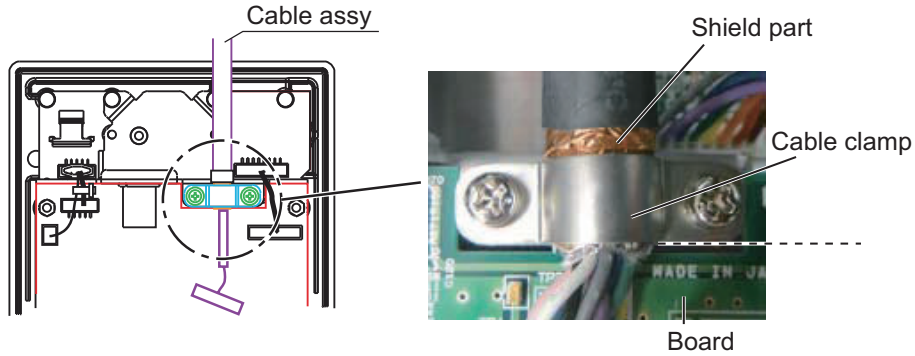

- Reattach the control unit cover.

Wiring for the processor unit

- Unfasten four screws (M4x8) to remove the processor unit cover.
- Unfasten three bolts to remove the cable clamp (upper) as shown below.

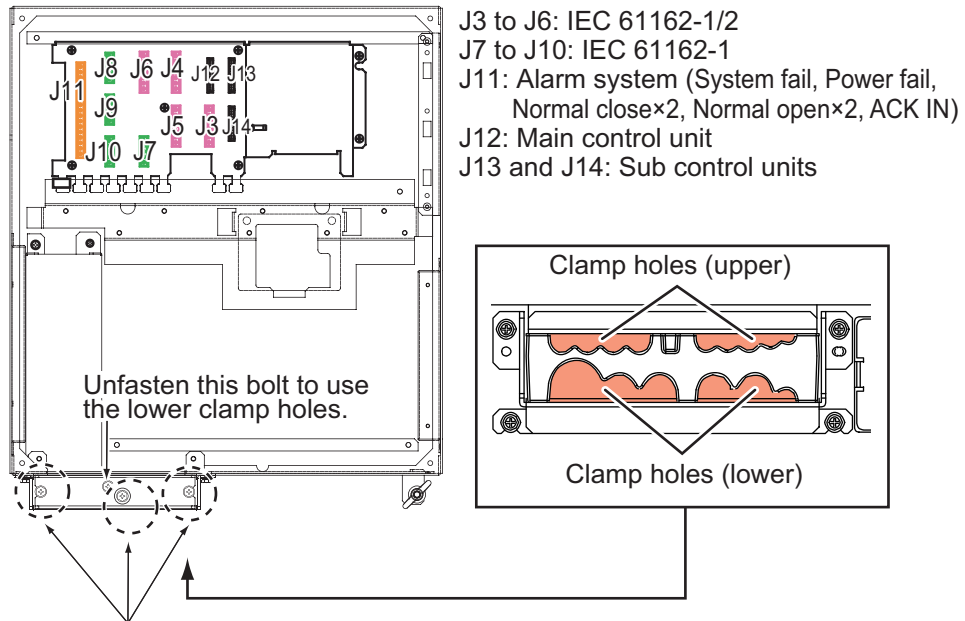

Unfasten these three bolts to remove the upper plate.

- Disconnect the control unit cable from the processor unit, then connect the cable assy (6TPSH-XH12X2-LxxSP2).
- Set the shield part of cables under the cable clamp then tighten the cable clamp.

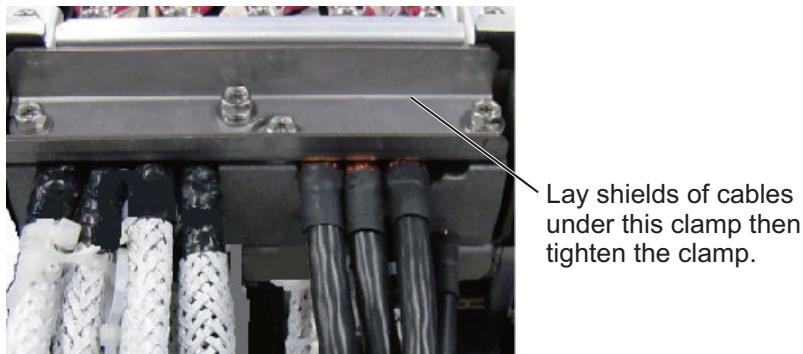

- Attach the processor unit cover.

2.6 Radar Connection Box (option)

The RCB-002 is capable of connecting the FMD-3×00 with up to two external radar systems. Referring to the figure below, connect the respective equipment to the RCB-002.

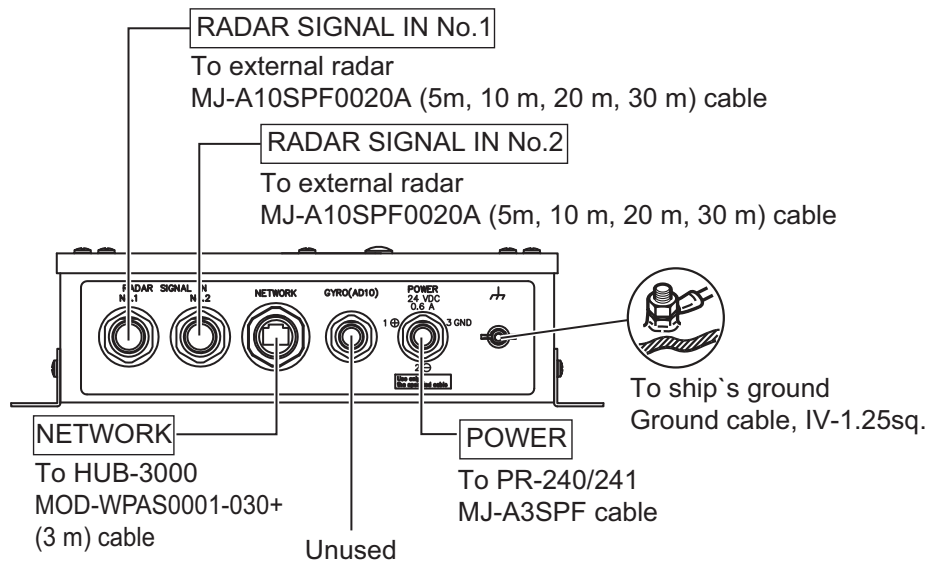

Connecting LAN cables

When connecting LAN cables (MOD-WPAS0001-030+) to the RCB-002, use the following procedure.

1. Unfasten and remove the sealing nut from the NETWORK port on the RCB-002, then remove the seal assembly. See the right figure for reference.

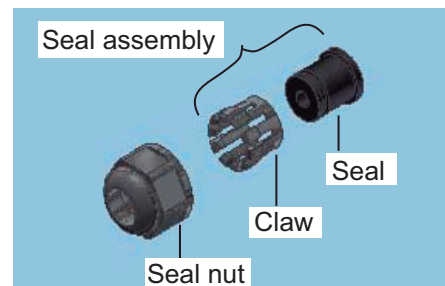

2. Dismantle the seal assembly as shown below.

Dismantling the seal assembly

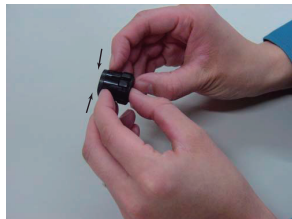

STEP 1:

Hold the larger diameter end of the seal assembly with both thumbs while placing index fingernails between the seal and the claw.

Use caution to avoid injury.



STEP 2:

Using your thumbs, gently push the seal out of the claw.

2. WIRING

- Referring to the figure below, pass the LAN cable through the seal nut, then the claw and finally the seal.

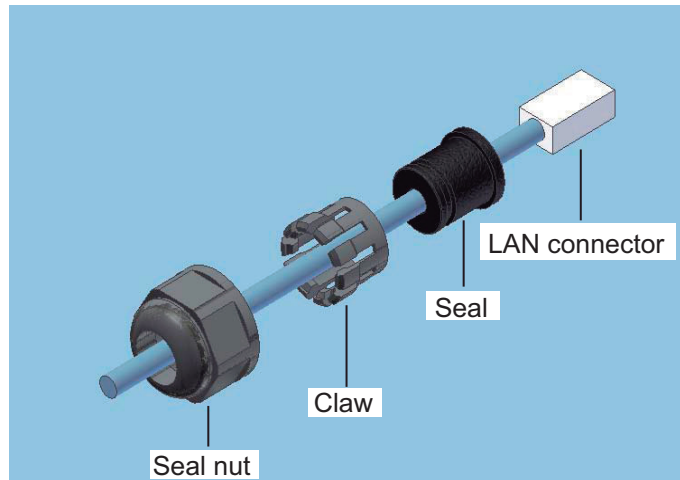

- Connect the LAN cable to the connector.
- Join the claw and seal to form the seal assembly, then firmly join the seal assembly to the LAN connector.
- Fasten the seal nut and secure the cable. Continue to fasten the nut until the space between the two nuts is approximately 3 mm. See the figure below for reference.

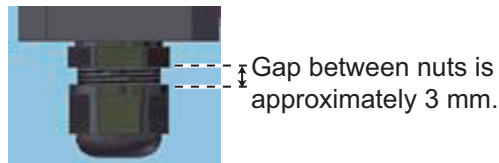

2.6.1 Jumper settings for RCB-002

The RCB-002 is compatible with the following radars.

Maker	Model	Maker	Model
FURUNO*	<ul style="list-style-type: none"> • FAR-14×7 series • FAR-2××7 series • FAR-2××5 series • Model 1835 	Japan Radio Company (JRC)	JMA-9100 series
		Tokyo Keiki Inc.	BR-3440 series
		*: FURUNO radars are only compatible with the CH2 (RADAR SIGNAL IN NO.2 port).	

Change the jumper settings on the RA/IF board (24P0140) according to the radar to be connected, referring the tables on the next page. For details of the values for each jumper block on the RA/IF board (24P0140), see "RA/IF BOARD JUMPER VALUES" on page AP-8.

Jumper locations on the RA/IF board (24P0140)

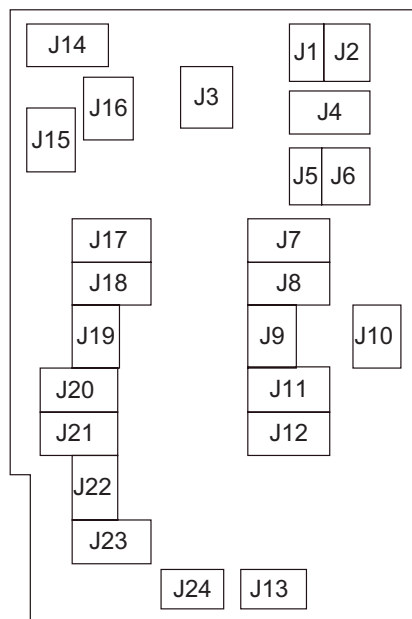

CH1 settings (RADAR SIGNAL IN NO.1)

Using the table below for reference, change the jumper settings to suit the appropriate radar connection. Use the figure on the previous page for jumper locations.

Jumper	Radar to be connected	
	JMA-9100 series	BR-3440 series
J1	#2-3: short	
J2	#3-6: short	
J3	#2-6: short	#1-5: short
J4	#1-2: short	
J5	#2-3: short	
J6	#3-6: short	
J10	#3-7: short	#2-6: short
J13	#1-2: short	#2-3: short

CH2 settings (RADAR SIGNAL IN NO.2)

Using the table below for reference, change the jumper settings to suit the appropriate radar connection. Use the figure on the previous page for jumper locations.

Jumper	Radar to be connected		
	FURUNO radars	JMA-9100 series	BR-3440 series
J7	#2-3: short	#1-2: short	
J8	#1-2: short	#2-3: short	
J9	#1-4: short	#3-6: short	
J11	#2-3: short	#1-2: short	
J12	#1-2: short	#1-2: short	
J14	#2-3: short	#1-2: short	
J15	#2-3: short	#1-2: short	
J16	#2-6: short	#2-6: short	#1-5: short
J17	#2-3: short	#1-2: short	
J18	#1-2: short	#2-3: short	
J19	#1-4: short	#3-6: short	
J20	#2-3: short	#1-2: short	
J21	#2-3: short	#1-2: short	
J22	#3-7: short	#3-7: short	#2-6: short
J23	#2-3: short	#1-2: short	
J24	#1-2: short	#1-2: short	#2-3: short

2.7 Raytheon Anschutz Autopilot NP-5400

2.7.1 General interconnection diagram

The NP-5400 connects to the FMD as shown in the figure below. For details, see the Raytheon Anschutz installation manual.

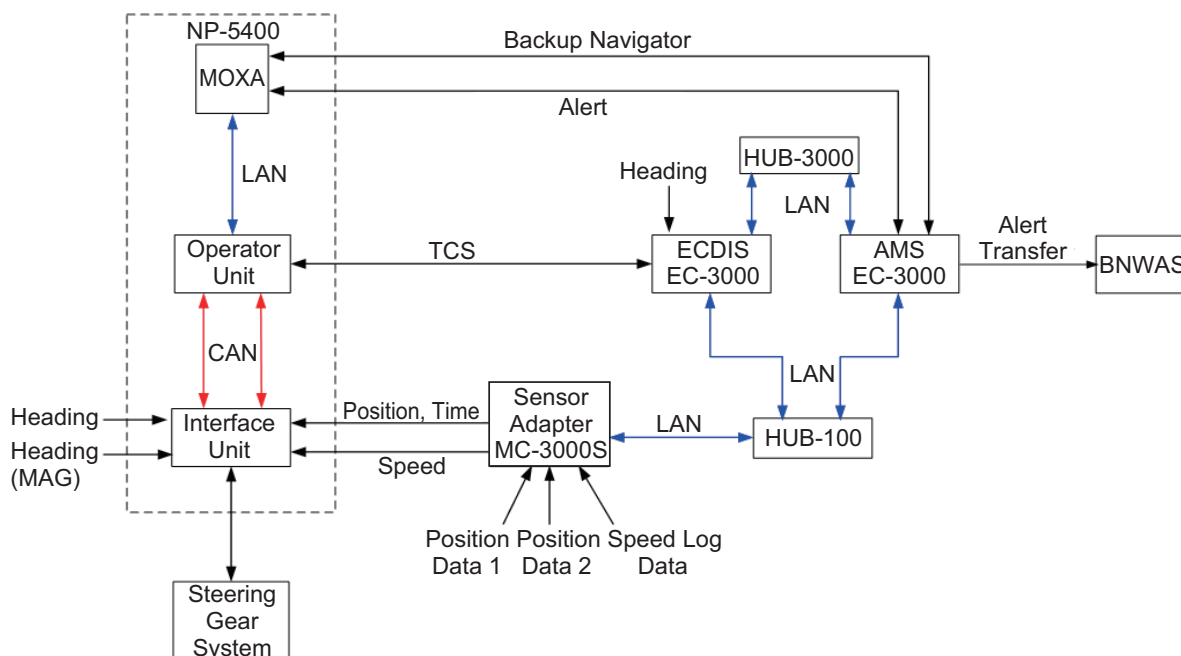

Notes on the connection

- Speed data**
 Speed data is output from the MC-3000S to the NP-5400. Make sure the MC-3000S is connected and set up to output speed data.
- Position and time data**
 Position and time data are output from the MC-3000S to the NP-5400. Make sure the MC-3000S is connected and set up to output position and time data.
- BNWAS connection**
 When AMS is also installed, the Backup Navigator Alarm is output to the BNWAS via the AMS. Connect both AMS and BNWAS. Note that it is not necessary to connect either the ECDIS or the NP-5400 to the BNWAS.
- Position and speed data input to the FMD**
 Do not input position and speed data directly to the FMD. Input the data to the FMD via the MC-3000S. This allows that data to be input to the NP-5400 when the ECDIS EC-3000 is powered off. Note that heading data can be input directly to the ECDIS EC-3000.

2.7.2 When the Raytheon Anschutz Steering Gear System will not be used

When the Raytheon Anschutz Steering Gear System will not be used, take the following measures to detect and announce autopilot interface failure.

- The preferred method is to use the 4-20mA output of the track control system when the steering gear control system provides the failure detection and response as described below. This method requires only the rudder order information and does not require any additional status transfer between the autopilot and the steering gear control system.
- The second best method is to use $\pm 10V$ when the steering gear control system provides the failure detection and response as described below. Compared to the 4-20mA interfaced an additional failure input is required in the steering gear control system.
- The use of an additional analog memory device requires a failure input in order to activate the memory function and a switch over of the rudder order from the track control system (in their case the Autopilot Interface AS) to the analog memory device. This method should only be used if the steering gear control system does not provide the functions as described above.

Failure of the Autopilot Interface AS and interface system type

What occurs when the Autopilot Interface AS fails depends on the type of interface system used.

- 4-20mA interface
 - System failure alert generated.
 - Rudder order from the Autopilot Interface AS to the steering gear control system goes to 0mA
 - The steering gear control system detects a failure as 0mA is an invalid value.
 - Steering gear control system maintains the rudder angle.
- $\pm 10V$ interface
 - System failure alert generated.
 - Rudder order from the Autopilot Interface AS to the steering gear control system goes to 0V.
 - Input of the system failure alert to the steering gear control system.
 - Steering gear control system maintains the rudder angle.

3. ECN-303/304 (OPTION)

This section provides the information necessary for installing the display unit console ECN-303/304.

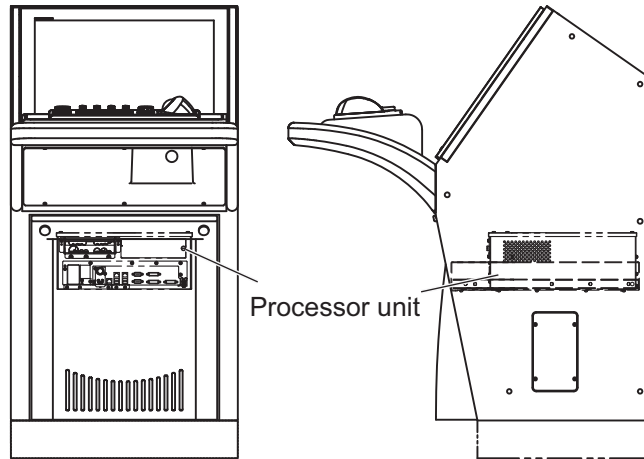

3.1 How to Install the Console

1. Install a channel base (height: 100 mm), consulting with the shipyard.
2. Pass a lifting belt through the four eye bolts at the top of the console. Hoist the console with a crane and place it on top of the channel base.
3. Remove the front cover of the console by unfastening two screws.

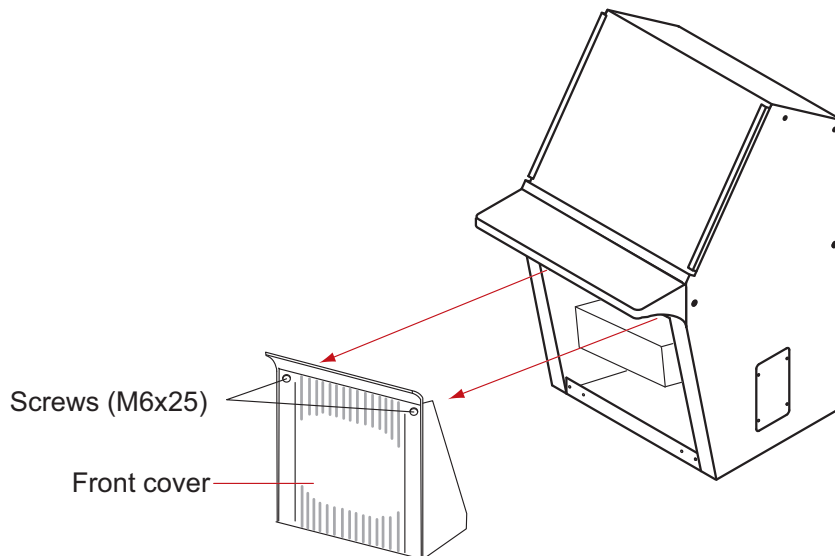

4. Fix the console to the channel base with six hexagon head bolts (M12, local supply).
5. Remove the four eye bolts. Cover the four holes for the eye bolts with the caps supplied.

3.2 How to Dismount the Rack for the Processor Unit

If it is difficult to access the inside bottom of the console (for wiring), follow the procedure in this section to remove the rack for the processor unit. Otherwise, go to section 3.3 How to Connect the External Cables.

Note 1: Leave sufficient space at the sides and rear of the unit to facilitate maintenance.

Note 2: Confirm that the power switch of the ECDIS is turned off before starting the installation.

1. Unfasten the cable clamp at the top-left hand side in the console to release the power cable.

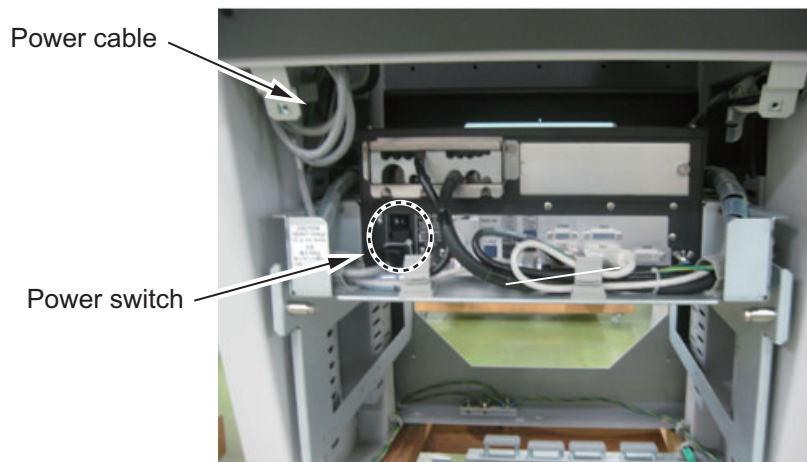

2. Unfasten two hex. bolts (M6) to pull the rack for the processor unit toward you until you hear a click.
The rack comes to a stop against the stoppers on the right and left rails.

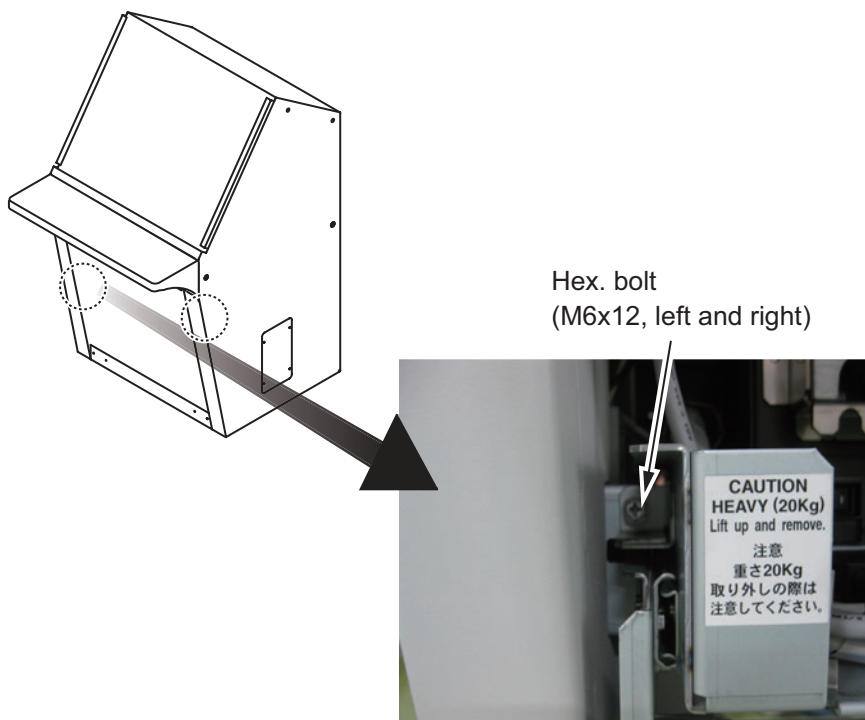

3. Release all cables other than the power cable from their cable clamps. There are six cable clamps on the rack as shown below.

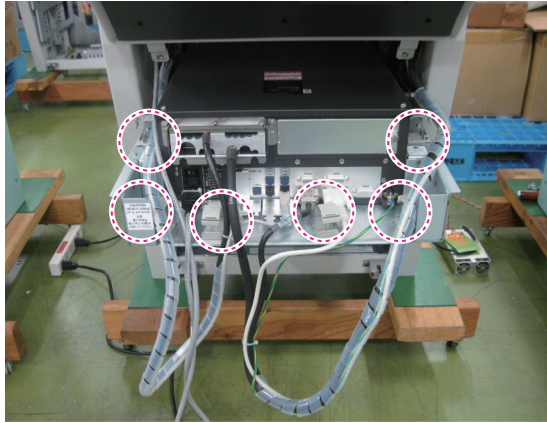

4. Press the stoppers with your fingers to unlock them to release the rack, then pull out the rack slowly.

Note 1: When dismantling the processor unit from the console, be careful not to apply tension on the cables.

Note 2: The processor unit weighs 20 kg. Hold the rack securely so that it will not drop to the deck.

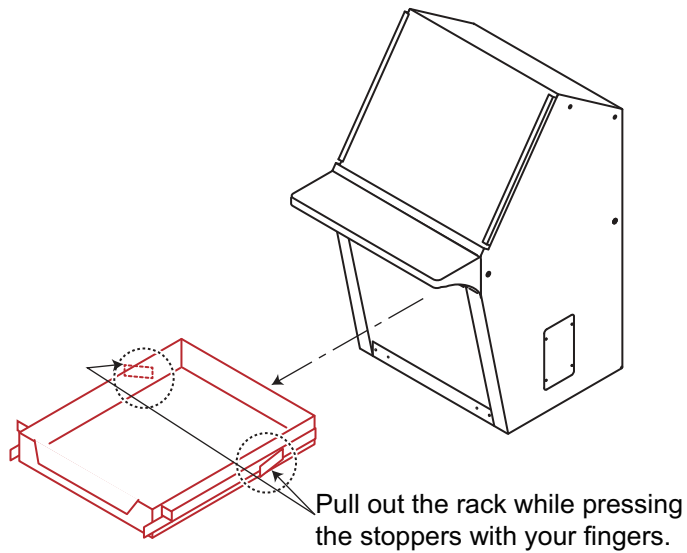

3.3 How to Connect External Cables

Pass the cables from external equipment through the bottom of the console. Connect the cables to the terminal board as shown in the interconnection diagrams in this manual and the label attached to the bottom of the console. Lay shields of cables under clamps then tighten clamps.

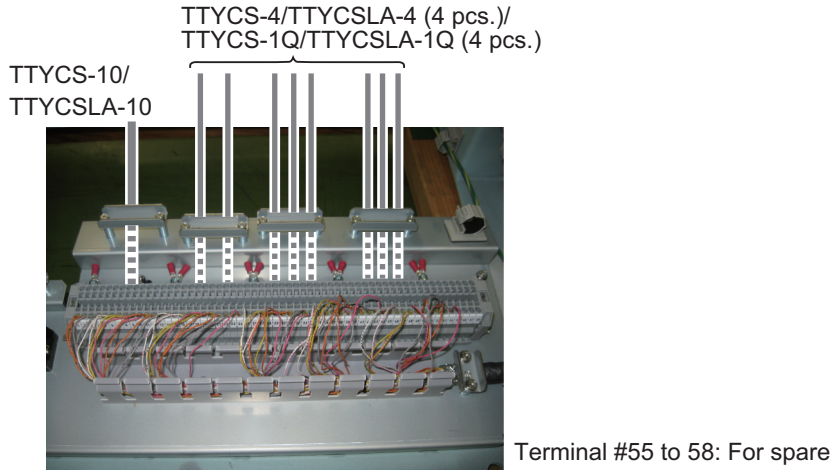

Note 1: The illustration below shows where to locate cables on the cable clamp. The location for the TTYCS-4/TTYCSLA-4 cables can alternately accommodate TTYCS-1Q/TTYCSLA-1Q cables. In this case, unfasten two hex. bolts to remove the clamp plate and fasten it behind the clamp base.

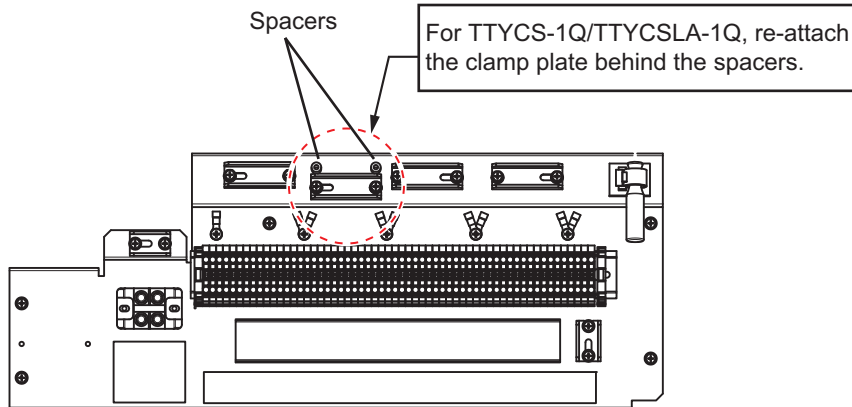

Note 2: For TTYCSLA cables, attach their drain wires to the crimp-on lugs pre-fasted near the terminal board.

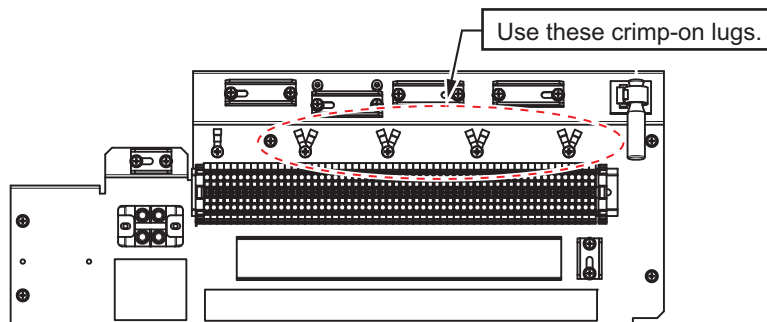

Fabrication of TTYCS cable

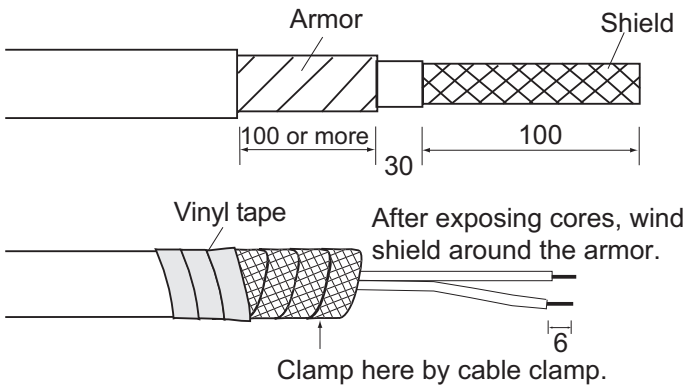

Fabrication of TTYCSLA cable

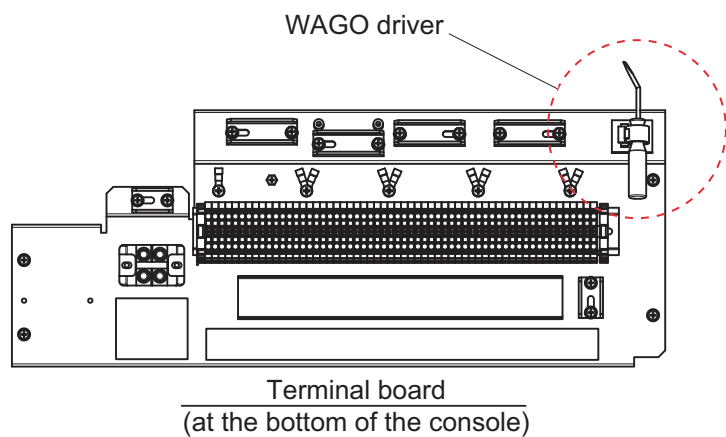
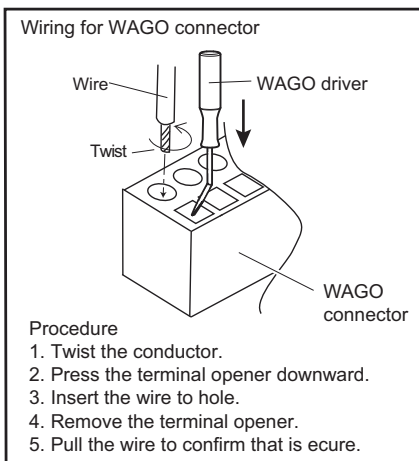
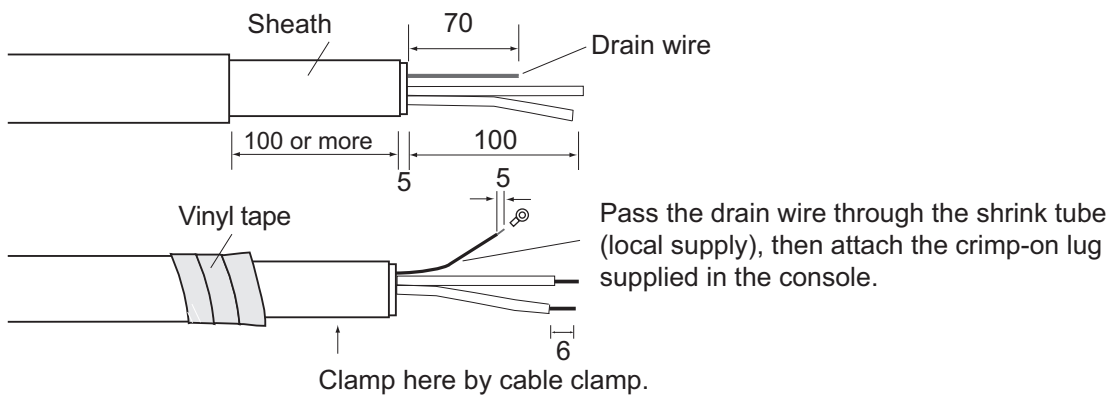

- Connectors J3 to J6 on the I/O Board in the processor unit can be set to IEC 61162-1 or IEC 61162-2. This console is shipped with the setting for IEC 61162-2.
- The connector J11 on the I/O Board in the processor unit can be set to the contact input or digital input. This console is shipped with the setting for the contact input.

3.4 How to Mount the Rack for the Processor Unit

After completing the wiring, remount the rack if it was removed at section 3.2.

Note: Leave sufficient space at the sides and rear of the unit to facilitate maintenance.

1. Confirm that the power switch on the EC-3000 is turned off before doing this procedure.
2. Set the rack for the processor unit to the rails until the rack contacts the stoppers on the rails.

Note 1: When remounting the processor unit from the console, be careful not to apply tension to cables.

Note 2: The processor unit weighs 20 kg. Hold the rack securely so that it will not drop to the deck.

Note 3: Do not tilt the processor unit to insert into the console unit.

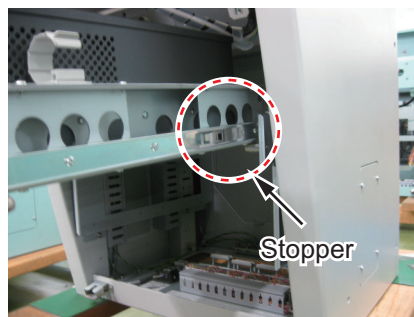

If you could not put the rack on the rails immediately, you can rest the rack on the spacers shown below.

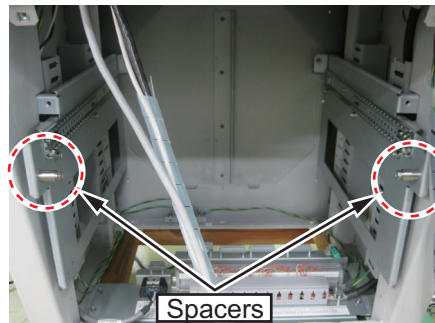

3. Fasten the cables from the processor unit with clamps at the left and right hand sides of the rack at the position of the red-colored marks on the cables.

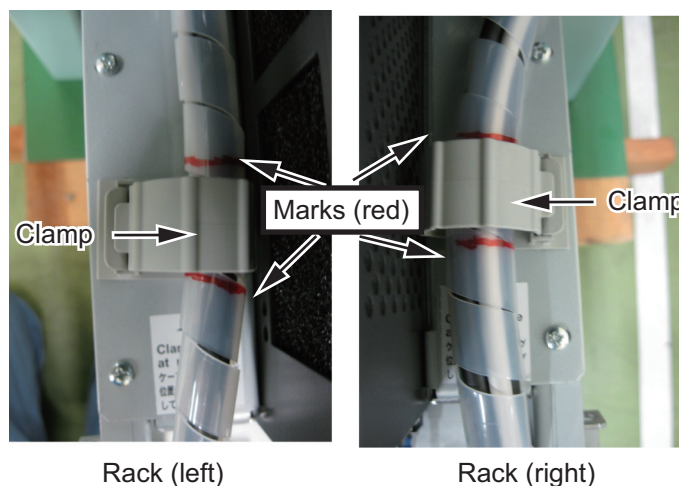

4. Press the stoppers with your fingers to unlock them to release the rack, then push the rack into the console.
5. Fasten two hex. bolts (M6, removed at step 2 in section 3.2.) to fix the rack to the console.
6. Fasten the cables from the processor unit with four clamps at the front of the rack.

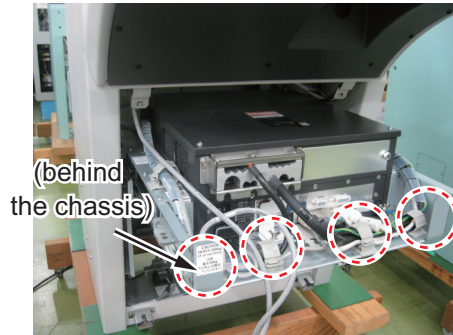

Location of four clamps

7. Use the clamp (see step 1 in section 3.2) to refasten the power cable.
Note: Confirm that the dummy plate covers the power switch.

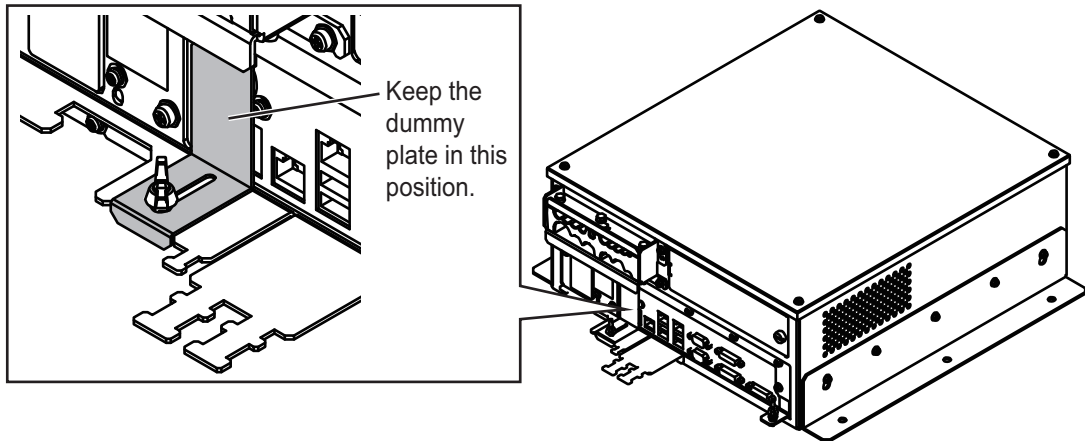

8. Fix the front cover to the console with two screws.

3. ECN-303/304 (OPTION)

This page is intentionally left blank.

4. SETTING UP THE EQUIPMENT

Set up the ECDIS from the [Common Installation Setting] menu after the installation. For details of the [Common Installation Setting] menu, see the instruction manual (E42-02113).

4. SETTING UP THE EQUIPMENT

This page is intentionally left blank.

APPX. 1 JIS CABLE GUIDE

Cables listed in the manual are usually shown as Japanese Industrial Standard (JIS). Use the following guide to locate an equivalent cable locally.

JIS cable names may have up to 6 alphabetical characters, followed by a dash and a numerical value (example: DPYC-2.5).

For core types D and T, the numerical designation indicates the *cross-sectional Area (mm²)* of the core wire(s) in the cable.

For core types M and TT, the numerical designation indicates the *number of core wires* in the cable.

1. Core Type

D: Double core power line

T: Triple core power line

M: Multi core

TT: Twisted pair communications
(1Q=quad cable)

2. Insulation Type

P: Ethylene Propylene Rubber

3. Sheath Type

Y: PVC (Vinyl)

4. Armor Type

C: Steel

5. Sheath Type

Y: Anticorrosive vinyl sheath

6. Shielding Type

SLA: All cores in one shield, plastic tape w/aluminum tape

-SLA: Individually shielded cores, plastic tape w/aluminum tape



DPYC



TPYC

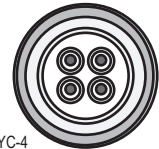

MPYC-4

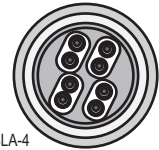

TTYCSLA-4

EX: ¹ ³ ⁴ ⁵ ⁶ **TTYCSLA - 4**
 Designation type | # of twisted pairs

¹ ² ³ ⁴ **MPYC - 4**
 Designation type | # of cores

The following reference table lists gives the measurements of JIS cables commonly used with Furuno products:

Type	Core Area	Core Diameter	Cable Diameter	Type	Core Area	Core Diameter	Cable Diameter
DPYC-1.5	1.5mm ²	1.56mm	11.7mm	TTYCSLA-1	0.75mm ²	1.11mm	9.4mm
DPYC-2.5	2.5mm ²	2.01mm	12.8mm	TTYCSLA-1T	0.75mm ²	1.11mm	10.1mm
DPYC-4	4.0mm ²	2.55mm	13.9mm	TTYCSLA-1Q	0.75mm ²	1.11mm	10.8mm
DPYC-6	6.0mm ²	3.12mm	15.2mm	TTYCSLA-4	0.75mm ²	1.11mm	15.7mm
DPYC-10	10.0mm ²	4.05mm	17.1mm	TTYCY-1	0.75mm ²	1.11mm	11.0mm
DPYCY-1.5	1.5mm ²	1.56mm	13.7mm	TTYCY-1T	0.75mm ²	1.11mm	11.7mm
DPYCY-2.5	2.5mm ²	2.01mm	14.8mm	TTYCY-1Q	0.75mm ²	1.11mm	12.6mm
DPYCY-4	4.0mm ²	2.55mm	15.9mm	TTYCY-4	0.75mm ²	1.11mm	17.7mm
MPYC-2	1.0mm ²	1.29mm	10.0mm	TTYCY-4SLA	0.75mm ²	1.11mm	19.5mm
MPYC-4	1.0mm ²	1.29mm	11.2mm	TTYCYSLA-1	0.75mm ²	1.11mm	11.2mm
MPYC-7	1.0mm ²	1.29mm	13.2mm	TTYCYSLA-4	0.75mm ²	1.11mm	17.9mm
MPYC-12	1.0mm ²	1.29mm	16.8mm	TTPYCSLA-1	0.75mm ²	1.11mm	9.2mm
TPYC-1.5	1.5mm ²	1.56mm	12.5mm	TTPYCSLA-1T	0.75mm ²	1.11mm	9.8mm
TPYC-2.5	2.5mm ²	2.01mm	13.5mm	TTPYCSLA-1Q	0.75mm ²	1.11mm	10.5mm
TPYC-4	4.0mm ²	2.55mm	14.7mm	TTPYCSLA-4	0.75mm ²	1.11mm	15.3mm
TPYCY-1.5	1.5mm ²	1.56mm	14.5mm				
TPYCY-2.5	2.5mm ²	2.01mm	15.5mm				
TPYCY-4	4.0mm ²	2.55mm	16.9mm				

APPX. 2 ROD TERMINALS

MC-3000S, MC-CS Board (24P0114)

Connector #	Pin #	Signal name	Rod terminal to use	Connected cable
J1	1	24V_VOUT	AI 0.34-6 TQ (blue)	MC1.5-W-Lxxx
	2	24V_GND		
	3	MODBUS-A	AI 0.14-8 GY (gray)	
	4	MODBUS-B		
	5	GND		

Connector #	Pin #	Signal name	Rod terminal to use	Connected cable
J2	1	24V_IN	AI 1.5-6 BK (black)	DPYC-1.5
	2	24V_GND		
	3	PWR_FAIL-A	AI 0.75-6 GY (Gray)	TTYCS-4 TTYCSLA-4
	4	PWR_FAIL-COM		
	5	PWR_FAIL-B		
	6	NC	-	-

Connector #	Pin #	Signal name	Rod terminal to use	Connected cable
J4	1	TD1-A	AI 0.75-6 GY (Gray)	TTYCS-4 TTYCSLA-4
	2	TD1-B		
	3	RD1-A		
	4	RD1-B		
	5	ISOGND1		
	6	RD1-H		
	7	RD1-C		

Connector #	Pin #	Signal name	Rod terminal to use	Connected cable
J5	1	TD2-A	AI 0.75-6 GY (gray)	TTYCS-4 TTYCSLA-4
	2	TD2-B		
	3	RD2-A		
	4	RD2-B		
	5	ISOGND2		
	6	RD2-H		
	7	RD2-C		

Connector #	Pin #	Signal name	Rod terminal to use	Connected cable
J6	1	TD3-A	AI 0.75-6 GY (gray)	TTYCS-4 TTYCSLA-4
	2	TD3-B		
	3	RD3-A		
	4	RD3-B		
	5	ISOGND3		
	6	RD3-H		
	7	RD3-C		

Connector #	Pin #	Signal name	Rod terminal to use	Connected cable
J7	1	TD4-A	AI 0.75-6 GY (gray)	TTYCS-4 TTYCSLA-4
	2	TD4-B		
	3	RD4-A		
	4	RD4-B		
	5	ISOGND4		
	6	RD4-H		
	7	RD4-C		
Connector #	Pin #	Signal name	Rod terminal to use	Connected cable
J8	1	TD5-A	AI 0.75-6 GY (gray)	TTYCS-1Q TTYCSLA-1Q
	2	TD5-B		
	3	RD5-H		
	4	RD5-C		
	5	TD6-A		TTYCS-1Q TTYCSLA-1Q
	6	TD6-B		
	7	RD6-H		
	8	RD6-C		
Connector #	Pin #	Signal name	Rod terminal to use	Connected cable
J9	1	TD7-A	AI 0.75-6 GY (gray)	TTYCS-1Q TTYCSLA-1Q
	2	TD7-B		
	3	RD7-H		
	4	RD7-C		
	5	TD8-A		TTYCS-1Q TTYCSLA-1Q
	6	TD8-B		
	7	RD8-H		
	8	RD8-C		

MC-3010A MC-ANLG Board (24P0115)

Connector #	Pin #	Signal name	Rod terminal to use	Connected cable
J1	1	24V_IN	AI 0.34-6 TQ (blue)	MC1.5-W-Lxxx
	2	24V_GND		
	3	MODBUS-A	AI 0.14-8 GY (gray)	
	4	MODBUS-B		
	5	GND		
Connector #	Pin #	Signal name	Rod terminal to use	Connected cable
J2	1	24V_OUT	AI 0.34-6 TQ (blue)	MC1.5-W-Lxxx
	2	24V_GND		
	3	MODBUS-A	AI 0.14-8 GY (gray)	
	4	MODBUS-B		
	5	GND		
Connector #	Pin #	Signal name	Rod terminal to use	Connected cable
J3*	1	AN1_IN	AI 0.75-6 GY (gray)	TTYCS-1 TTYCSLA-1
	2	AN1_GND		
	3	CURR1_JP1		
	4	CURR1_JP2		
Connector #	Pin #	Signal name	Rod terminal to use	Connected cable
J4*	1	AN2_IN	AI 0.75-6 GY (gray)	TTYCS-1 TTYCSLA-1
	2	AN2_GND		
	3	CURR2_JP1		
	4	CURR2_JP2		
Connector #	Pin #	Signal name	Rod terminal to use	Connected cable
J5*	1	AN3_IN	AI 0.75-6 GY (gray)	TTYCS-1 TTYCSLA-1
	2	AN3_GND		
	3	CURR3_JP1		
	4	CURR3_JP2		

*: For pin #3 and 4, no cable is connected. However the jumper connection is necessary depending on the input specification.

MC-3020D, MC-DIN Board (24P0116)

Connector #	Pin #	Signal name	Rod terminal to use	Connected cable
J1	1	24V_IN	AI 0.34-6 TQ (blue)	MC1.5-W-Lxxx
	2	24V_GND		
	3	MODBUS-A	AI 0.14-8 GY (gray)	
	4	MODBUS-B		
	5	GND		
Connector #	Pin #	Signal name	Rod terminal to use	Connected cable
J2	1	24V_OUT	AI 0.34-6 TQ (blue)	MC1.5-W-Lxxx
	2	24V_GND		
	3	MODBUS-A	AI 0.14-8 GY (gray)	
	4	MODBUS-B		
	5	GND		
Connector #	Pin #	Signal name	Rod terminal to use	Connected cable
J3*	1	DV12V_OUT1	AI 1-6 RD (red)	MPYC-12
	2	DIGI_IN1		
	3	DIGI_RTN1		
	4	GND		
	5	DC12V_OUT2		
	6	DIGI_IN2		
	7	DIGI_RTN2		
	8	GND		
Connector #	Pin #	Signal name	Rod terminal to use	Connected cable
J4*	1	DV12V_OUT3	AI 1-6 RD (red)	MPYC-12
	2	DIGI_IN3		
	3	DIGI_RTN3		
	4	GND		
	5	DC12V_OUT4		
	6	DIGI_IN4		
	7	DIGI_RTN4		
	8	GND		
Connector #	Pin #	Signal name	Rod terminal to use	Connected cable
J5*	1	DV12V_OUT5	AI 1-6 RD (red)	MPYC-12
	2	DIGI_IN5		
	3	DIGI_RTN5		
	4	GND		
	5	DC12V_OUT6		
	6	DIGI_IN6		
	7	DIGI_RTN6		
	8	GND		

*: Pin #1 and 5: no cable connection. However the jumper connection is necessary between #1 and 2 and #5 and 6 depending on the input specification.

APPX. 2 ROD TERMINALS

Connector #	Pin #	Signal name	Rod terminal to use	Connected cable
J6*	1	DV12V_OUT7	AI 1-6 RD (red)	MPYC-12
	2	DIGI_IN7		
	3	DIGI_RTN7		
	4	GND		
	5	DC12V_OUT8		
	6	DIGI_IN8		
	7	DIGI_RTN8		
	8	GND		

*: Pin #1 and 5: no cable connection. However the jumper connection is necessary between #1 and 2 and #5 and 6 depending on the input specification.

MC-3030D, MC-DOUT Board (24P0117)

Connector #	Pin #	Signal name	Rod terminal to use	Connected cable
J1	1	24V_IN	AI 0.34-6 TQ (blue)	MC1.5-W-Lxxx
	2	24V_GND		
	3	MODBUS-A	AI 0.14-8 GY (gray)	
	4	MODBUS-B		
	5	GND		
Connector #	Pin #	Signal name	Rod terminal to use	Connected cable
J2	1	24V_OUT	AI 0.34-6 TQ (blue)	MC1.5-W-Lxxx
	2	24V_GND		
	3	MODBUS-A	AI 0.14-8 GY (gray)	
	4	MODBUS-B		
	5	GND		
Connector #	Pin #	Signal name	Rod terminal to use	Connected cable
J3	1	A1	AI 1-6 RD (red)	MPYC-12
	2	COM1		
	3	B1		
	4	A2		
	5	COM2		
	6	B2		
Connector #	Pin #	Signal name	Rod terminal to use	Connected cable
J4	1	A3	AI 1-6 RD (red)	MPYC-12
	2	COM3		
	3	B3		
	4	A4		
	5	COM4		
	6	B4		
Connector #	Pin #	Signal name	Rod terminal to use	Connected cable
J5	1	A5	AI 1-6 RD (red)	MPYC-12
	2	COM5		
	3	B5		
	4	A6		
	5	COM6		
	6	B6		
Connector #	Pin #	Signal name	Rod terminal to use	Connected cable
J6	1	A7	AI 1-6 RD (red)	MPYC-12
	2	COM7		
	3	B7		
	4	A8		
	5	COM8		
	6	B8		

APPX. 3 RA/IF BOARD JUMPER VALUES

The values for each jumper block on the RA/IF board (24P0140) are shown below.

CH1/CH2 signal settings

J1/J8 HD-TERM		J3/J16 VID-TERM		J5/J18 BP-TERM		J10/J22 TRG-TERM	
1-2	1.2 k Ω	1-5	75 Ω	1-2	1.2 k Ω	1-5	50 Ω
2-3	OFF	2-6	50 Ω	2-3	OFF	2-6	75 Ω
J2/J9 HD-PULL UP		3-7	1.2 k Ω	J6/J19 BP-PULL UP		3-7	180k Ω
1-4	5V IN	4-8	100 k Ω	1-4	5V IN	4-8	1.2 k Ω
2-5	OC (560 Ω)	J4/J12 HD-POLARITY		2-5	OC (560 Ω)	J13/J24 BP-PULSE NUM	
3-6	OC (1 k Ω)	1-2	NORMAL	3-6	OC (1 k Ω)	1-2	2048
		2-3	REVERSE			2-3	1024







Input bypass settings (CH2 only)

J7/J11 HD-INTERFACE		J17/J20 BP-INTERFACE	
1-2	ADJUST	1-2	ADJUST
2-3	BYPASS	2-3	BYPASS
J14/J15 VID-INTERFACE		J21/J23	
1-2	ADJUST	1-2	ADJUST
2-3	BYPASS	2-3	BYPASS

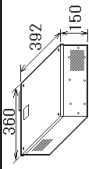
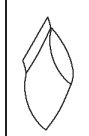
PACKING LIST

EC-3000-2xx9* , EC-3000-27*/32*/33* , EC-3000-T-27*/32*/33* , EC-3000-13

1/1

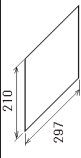
NAME	OUTLINE	DESCRIPTION/CODE No.	Q'TY
ユニット			
制御部 PROCESSOR UNIT		EC-3000-*	1
		000-020-737-00	**
予備品			
予備品 SPARE PARTS		SP24-00601	1
		001-170-660-00	(*1)
予備品 SPARE PARTS		SP24-00602	1
		001-170-670-00	(*1)
付属品			
付属品 ACCESSORIES		FP24-00601	1
		001-170-650-00	(*2)
付属品 ACCESSORIES		FP24-00602	1
		001-258-570-00	(*2)
工事材料			
ケーブル(クミヒ) CABLE ASSEMBLY		DSUB9P-X2-L5M	1
		000-176-663-11	
工事材料 INSTALLATION MATERIALS		GP24-02101	1
		001-170-630-00	
電源ケーブル AC CABLE		IEC60320-C13-L5M	1
		000-176-423-11	
図書	DOCUMENT		
ドングルインフォメーションシート DONGLE INFORMATION SHEET			1
		999-999-085-0*	(*1)

1.コード番号末尾の「*」は、選用品の代表コードを表します。
 CODE NUMBER ENDING WITH "*" INDICATES THE CODE NUMBER OF REPRESENTATIVE MATERIAL
 2.(*1)(*2)(*3)(*4)(*5)は、それぞれ仕様選用品を表します。
 (*1)(*2)(*3)(*4)(*5)INDICATE SPECIFICATION SELECTIVE ITEM.
(略図の寸法は、参考値です。 DIMENSIONS IN DRAWING FOR REFERENCE ONLY.)

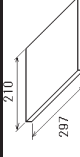
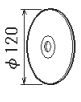
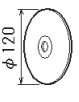
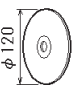
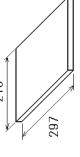
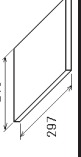
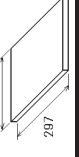
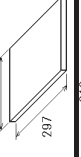
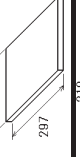
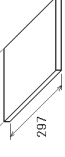
NAME	OUTLINE	DESCRIPTION/CODE No.	Q'TY
装備設定要領 INSTRUCTION MANUAL		*42-01204-*	1
		000-194-859-1*	**
取扱説明CD OPERATOR' S MANUAL CD		FMD3X00 O/M *CDROM*J	1
		000-194-856-1*	(*3)
取扱説明CD OPERATOR' S MANUAL CD		FMD3X00 O/M *CDROM*	1
		000-194-779-1*	(*3)
取扱説明CD OPERATOR' S MANUAL CD		FOR2X9 O/M *CDROM*E	1
		000-176-722-1*	(*3)
操作要領書 OPERATOR' S GUIDE		OS*-44730-*	1
		000-176-127-1*	**
操作要領書 OPERATOR' S GUIDE		OSE-36040-*	1
		000-176-133-1*	(*4)
装備要領書 INSTALLATION MANUAL		IME-44730-*	1
		000-195-306-1*	(*5)
装備要領書 INSTALLATION MANUAL		IME-36040-*	1
		000-176-135-1*	(*5)
装備要領書 INSTALLATION MANUAL		IME-36060-*	1
		000-176-137-1*	(*5)
装備要領書 INSTALLATION MANUAL		IME-36100-*	1
		000-176-139-1*	(*5)

3.(*1)は、タミコートに付き、注文できません。
 (6)THIS CODE CANNOT BE ORDERED.







A-1

C4473-Z01-P

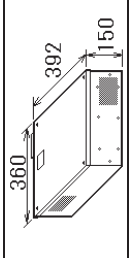
PACKING LIST

24AL-X-9866-13 1/1

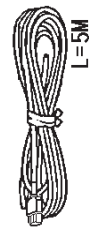
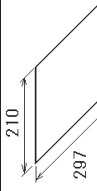





EC-3000*V EC-3000-27*V/32*V/33*V , EC-3000-T-27*V/32*V/33*V
 , EC-3000-R27/32/33-**

NAME	OUTLINE	DESCRIPTION/CODE No.	Q'TY
ユニット			
制御部		EC-3000-*	1
PROCESSOR UNIT		000-020-737-00 **	**
付属品	ACCESSORIES		
付属品		FP24-00601	1
ACCESSORIES		001-170-650-00	(*1)
付属品		FP24-00602	1
ACCESSORIES		001-258-570-00	(*1)
工事材料	INSTALLATION MATERIALS		
ケーブル(クミヒン)		DSUB9P-X2-L5M	1
CABLE ASSEMBLY		000-176-663-11	
工事材料		CP24-02101	1
INSTALLATION MATERIALS		001-170-630-00	
電源ケーブル		IEC60320-C13-L5M	1
AC CABLE		000-176-423-11	
図書	DOCUMENT		
ドングルインフォメーションシート			1
DONGLE INFORMATION SHEET		999-999-085-0*	(*)
装備設定要領		*42-01204-*	1
INSTRUCTION MANUAL		000-194-859-1* **	**

1.コード番号末尾の[**]は、選用品の代表コードを表します。
 CODE NUMBER ENDING WITH "**" INDICATES THE CODE NUMBER OF REPRESENTATIVE MATERIAL.

2.(*1)(*2)(*3)(*4)は、それぞれ仕様選用品を表します。
 (*1)(*2)(*3)(*4)INDICATE SPECIFICATION SELECTIVE ITEM.

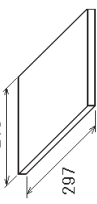
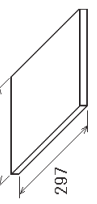
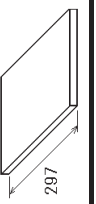

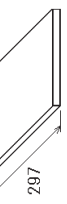

(略図の寸法は、参考値です。 DIMENSIONS IN DRAWING FOR REFERENCE ONLY.)

NAME	OUTLINE	DESCRIPTION/CODE No.	Q'TY
取扱説明CD		FMD3X00 O/M *CDROM*J	1
OPERATOR'S MANUAL CD		000-194-856-1*	(*2)
取扱説明CD		FMD3X00 O/M *CDROM*	1
OPERATOR'S MANUAL CD		000-194-779-1*	(*2)
取扱説明CD		FCR2XX9 O/M *CDROM*E	1
OPERATOR'S MANUAL CD		000-176-722-1*	(*2)
操作要領書		OS*-44730-*	1
OPERATOR'S GUIDE		000-176-127-1* **	(*3)
操作要領書		OSE-36040-*	1
OPERATOR'S GUIDE		000-176-133-1*	(*3)
装備要領書		IM*-44730-*	1
INSTALLATION MANUAL		000-195-306-1* **	(*4)
装備要領書		IME-36040-*	1
INSTALLATION MANUAL		000-176-135-1*	(*4)
装備要領書		IME-36060-*	1
INSTALLATION MANUAL		000-176-137-1*	(*4)
装備要領書		IME-36100-*	1
INSTALLATION MANUAL		000-176-139-1*	(*4)

3.(*)は、タミコードに付き、注文できません。
 (*) THIS CODE CANNOT BE ORDERED.

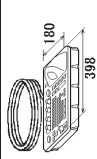
PACKING LIST
RCU-024B , RCU-024B-HK

24AL-X-9879 -2 1/1
A-3

NAME	OUTLINE	DESCRIPTION/CODE No.	Q'TY
ユニット			
ECDIS操作部		RCU-024B*	1
ECDIS CONTROL UNIT		000-037-640-00 **	
付属品			
付属品		FP24-00701	1
ACCESSORIES		001-418-340-00	
工事材料			
ケーブル(クビレ)USB		TS-20-071-1 L=5000	1
CABLE ASSEMBLY		000-176-700-11	
工事材料		CP24-02201	1
INSTALLATION MATERIALS		001-418-330-00	





コード番号末尾の[**]は、選択品の代表コードを表します。
CODE NUMBER ENDING WITH "**" INDICATES THE CODE NUMBER OF REPRESENTATIVE MATERIAL

(略図の寸法は、参考値です。 DIMENSIONS IN DRAWING FOR REFERENCE ONLY.)

CN
C4473-Z31-C

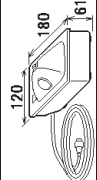
PACKING LIST
RCU-026/-HK

24AL-X-9881 -0 1/1
A-4

NAME	OUTLINE	DESCRIPTION/CODE No.	Q'TY
ユニット			
トラックボール操作部		RCU-026/-HK	1
TRACKBALL CONTROL UNIT		000-027-666-00 **	
付属品			
付属品		FP24-00801	1
ACCESSORIES		001-418-410-00	
工事材料			
ケーブル(クビレ)USB		TS-20-071-1 L=5000	1
CABLE ASSEMBLY		000-176-700-11	
工事材料		CP24-02301	1
INSTALLATION MATERIALS		001-418-400-00	





コード番号末尾の[**]は、選択品の代表コードを表します。
CODE NUMBER ENDING WITH "**" INDICATES THE CODE NUMBER OF REPRESENTATIVE MATERIAL

型式/コード番号が2段の場合、下段より上段に代わる過渡期品であり、どちらかが入っています。なお、品質は変わりません。
TWO TYPES AND CODES MAY BE LISTED FOR AN ITEM. THE LOWER PRODUCT MAY BE SHIPPED IN PLACE OF THE UPPER PRODUCT. QUALITY IS THE SAME.

(略図の寸法は、参考値です。 DIMENSIONS IN DRAWING FOR REFERENCE ONLY.)

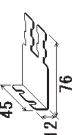
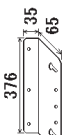
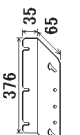
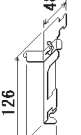
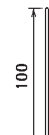
CN
C4473-Z33-A

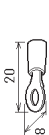
CODE NO.	001-170-630-00	24AL-X-9401-3
TYPE	CP24-02101	



番号 NO.	名称 NAME	略図 OUTLINE	型名/規格 DESCRIPTIONS	数量 Q'TY	用途/備考 REMARKS
1	配線板1 WIRING PLATE 1		24-014-0104-2 CODE NO. 100-369-012-10	1	
2	筐体足1 CHASSIS BASE 1		24-014-0121-1 CODE NO. 100-367-211-10	1	
3	筐体足2 CHASSIS BASE 2		24-014-0122-1 CODE NO. 100-372-171-10	1	
4	配線板2組立品 WIRING PLATE 2 ASSY		CP24-02102 CODE NO. 001-166-200-00	1	
5	コハネツガ CABLE TIE		CV-100N CODE NO. 000-162-167-10	10	
6	コハネツガ CABLE TIE		CV-150N CODE NO. 000-162-166-10	30	
7	圧着端子 CRIMP-ON LUG		FY1.25-4(LF) RED K CODE NO. 000-166-666-11	9	
8	+ハ イット コネツ BINDING HEAD SCREW		M3X6 SUS304 CODE NO. 000-162-664-10	5	
9	+ハ イット 小ネツ BINDING HEAD SCREW		M4X8 SUS304 CODE NO. 000-162-666-10	10	

(略図の寸法は、参考値です。 DIMENSIONS IN DRAWING FOR REFERENCE ONLY.)

FURUNO ELECTRIC CO., LTD.

C4473-M01-D

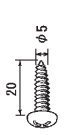
CODE NO.	001-418-330-00	24AL-X-9408-0
TYPE	CP24-02201	

工事材料表 INSTALLATION MATERIALS					
番号 NO.	名称 NAME	略図 OUTLINE	型名/規格 DESCRIPTIONS	数量 Q'TY	用途/備考 REMARKS
1	+ハツタツギネツコネツ SELF-TAPPING SCREW		5X20 SUS304 CODE NO. 000-162-608-10	2	
2	コハネツガ CABLE TIE		CV-125N CODE NO. 000-172-164-10	2	



型式/コード番号が2段の場合、下段より上段に代わる標準部品であり、どちらかが入っています。なお、品質は変わりません。
TWO TYPES AND CODES MAY BE LISTED FOR AN ITEM. THE LOWER PRODUCT MAY BE SHIPPED IN PLACE OF THE UPPER PRODUCT.
(略図の寸法は、参考値です。 DIMENSIONS IN DRAWING FOR REFERENCE ONLY.)

FURUNO ELECTRIC CO., LTD.

CN
C4473-M08-A

CODE NO.	001-418-400-00	24AL-X-9409-0
TYPE	CP24-02301	1/1

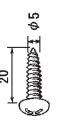

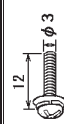
工事材料表

番号 NO.	名称 NAME	略図 OUTLINE	型名/規格 DESCRIPTIONS	数量 QTY	用途/備考 REMARKS
1	付着自在ネジ 1/2 SELF-TAPPING SCREW		5X20 SUS304 CODE NO. 000-162-608-10	2	
2	ケーブルタイ CABLE TIE		CV-125N CODE NO. 000-172-164-10	2	
3	ワッシャー WASHER HEAD SCREW #8*		M3X12 SUS304 CODE NO. 000-162-648-10	4	

型式/コード番号が異なる場合、下段より上段に代わる適量部品であり、どちらが入っています。なお、品質は変わりません。
 TWO TYPES AND CODES MAY BE LISTED FOR AN ITEM. THE LOWER PRODUCT MAY BE SHIPPED IN PLACE OF THE UPPER PRODUCT.
 QUALITY IS THE SAME.
 (略図の寸法は、参考値です。 DIMENSIONS IN DRAWING FOR REFERENCE ONLY.)

CODE NO.	001-258-570-00	24AL-X-9509-0
TYPE	FP24-00602	1/1

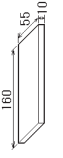
付属品表

番号 NO.	名称 NAME	略図 OUTLINE	型名/規格 DESCRIPTIONS	数量 QTY	用途/備考 REMARKS
1	防塵スポンジ DUST-PROOF SPONGE		Z4-014-0105-1 CODE NO. 100-366-821-10	1	
2	DVD-R 書き込み品 ACCESSORIES		2450110- CODE NO. 001-258-580-30	1	



型式/コード番号が異なる場合、下段より上段に代わる適量部品であり、どちらが入っています。なお、品質は変わりません。
 TWO TYPES AND CODES MAY BE LISTED FOR AN ITEM. THE LOWER PRODUCT MAY BE SHIPPED IN PLACE OF THE UPPER PRODUCT.
 QUALITY IS THE SAME.
 (略図の寸法は、参考値です。 DIMENSIONS IN DRAWING FOR REFERENCE ONLY.)

FURUNO

CODE NO.	001-418-340-00	24AL-X-9511-0	1/1
TYPE	FP24-00701		

付属品表

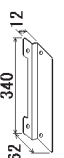
ACCESSORIES

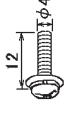
番号 NO.	名称 NAME	略図 OUTLINE	型名/規格 DESCRIPTIONS	数量 QTY	用途/備考 REMARKS
1	卓上取付板 DESK FIXING PLATE		24-014-1401-0 CODE NO. 100-367-400-10	1	
2	USBシート USB SHEET		24-014-1411-0 CODE NO. 100-372-000-10	1	
3	ワッシャー WASHER HEAD SCREW #B*		MAX12 027001 MEN12 CODE NO. 000-163-192-10	4	

型式/コード番号が2枚の場合、下段より上段に代わる通達部品であり、どちらかが入っています。なお、品質は変わりません。
TWO TYPES AND CODES MAY BE LISTED FOR AN ITEM. THE LOWER PRODUCT MAY BE SHIPPED IN PLACE OF THE UPPER PRODUCT.
QUALITY IS THE SAME.
(略図の寸法は、参考値です。DIMENSIONS IN DRAWING FOR REFERENCE ONLY.)

FURUNO ELECTRIC CO., LTD.

CN



C4473-F09-A

FURUNO

CODE NO.	001-418-410-00	24AL-X-9512-0	1/1
TYPE	FP24-00801		

付属品表

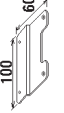
ACCESSORIES

番号 NO.	名称 NAME	略図 OUTLINE	型名/規格 DESCRIPTIONS	数量 QTY	用途/備考 REMARKS
1	卓上取付板 DESKTOP FIXING PLATE		14-076-2311-0 CODE NO. 100-364-730-10	1	
2	USBシート USB SHEET		24-014-1411-0 CODE NO. 100-372-000-10	1	
3	ワッシャー WASHER HEAD SCREW #B*		MAX8 SUS304 CODE NO. 000-162-649-10	2	

型式/コード番号が2枚の場合、下段より上段に代わる通達部品であり、どちらかが入っています。なお、品質は変わりません。
TWO TYPES AND CODES MAY BE LISTED FOR AN ITEM. THE LOWER PRODUCT MAY BE SHIPPED IN PLACE OF THE UPPER PRODUCT.
QUALITY IS THE SAME.
(略図の寸法は、参考値です。DIMENSIONS IN DRAWING FOR REFERENCE ONLY.)

FURUNO ELECTRIC CO., LTD.

CN

C4473-F10-A

FURUNO

CODE NO.	001-170-660-00	24AL-X-9301-3	1/1
TYPE	SP24-00601	BOX NO.	P

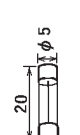
SHIP NO.	SPARE PARTS LIST FOR		U S E			REMARKS/CODE NO.
			WORKING	PER SET	SPARE	
ITEM NO.	NAME OF PART	OUTLINE	DWG. NO. OR TYPE NO.	QUANTITY	PER VESSEL	SETS PER VESSEL
1	GLASS TUBE FUSE		FGMB-S 125V 10A PBF	1	1	3
			000-157-470-10			
MFR'S NAME	FURUNO ELECTRIC CO., LTD.		DWG NO.	C4473-P01-D		1/1

(略図の寸法は、参考値です。 DIMENSIONS IN DRAWING FOR REFERENCE ONLY.)

FURUNO

CODE NO.	001-170-670-00	24AL-X-9302-3	1/1
TYPE	SP24-00602	BOX NO.	P

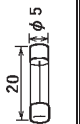
SHIP NO.	SPARE PARTS LIST FOR		U S E			REMARKS/CODE NO.
			WORKING	PER SET	SPARE	
ITEM NO.	NAME OF PART	OUTLINE	DWG. NO. OR TYPE NO.	QUANTITY	PER VESSEL	SETS PER VESSEL
1	GLASS TUBE FUSE		FGMB-A 250V 5A PBF	1	1	3
			000-157-570-10			
MFR'S NAME	FURUNO ELECTRIC CO., LTD.		DWG NO.	C4473-P02-D		1/1

(略図の寸法は、参考値です。 DIMENSIONS IN DRAWING FOR REFERENCE ONLY.)

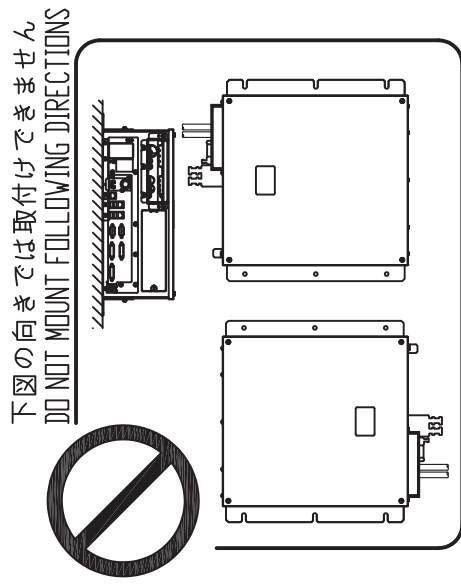
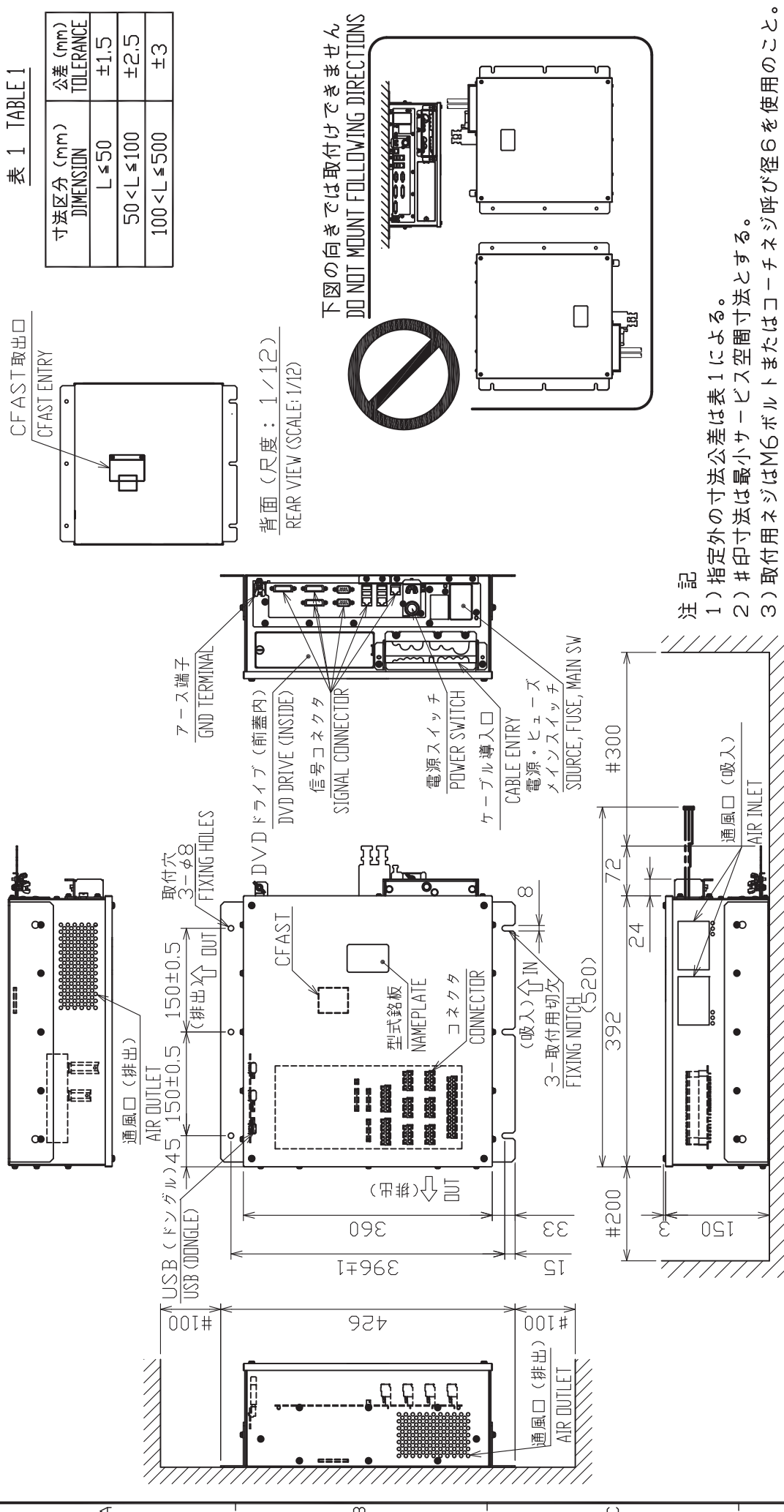

注 記

- 1) 指定外の寸法公差は表 1 による。
- 2) # 印寸法は最小サービス空間寸法とする。
- 3) 取付用ネジは M6 ボルトまたはコーネジ呼び径 6 を使用のこと。
- 4) DVD ドライブの向きは左右いずれかとする。切欠きが下向きとなるよう取付金具 (工材) を本体に取り付ける。

NOTE

1. TABLE 1 INDICATES TOLERANCE OF DIMENSIONS WHICH IS NOT SPECIFIED.
2. # MINIMUM SERVICE CLEARANCE.
3. USE M6 BOLTS OR CORNER SCREWS Ø6 FOR FIXING THE UNIT.
4. FACE THE DVD DRIVE TO RIGHT OR LEFT SIDE EITHER. MOUNT THE FIXING PLATES (SUPPLIED) TO THE CHASSIS AS THE FIXING NOTCH FACES TO BOTTOM.

DRAWN	29/Nov/2017 T.YAMASAKI	TITLE	EC-3000
CHECKED	29/Nov/2017 H.MAKI	各種	制御部 (壁掛装備)
APPROVED	29/Nov/2017 H.MAKI	外寸図	
SCALE	1/8	NAME	PROCESSOR UNIT (BULKHEAD MOUNT)
FIG.No.	C4473-G01-D	REF.No.	24-014-011G-3
			OUTLINE DRAWING

表 1 TABLE 1

寸法区分 (mm) DIMENSION	公差 (mm) TOLERANCE
L ≤ 50	±1.5
50 < L ≤ 100	±2.5
100 < L ≤ 500	±3

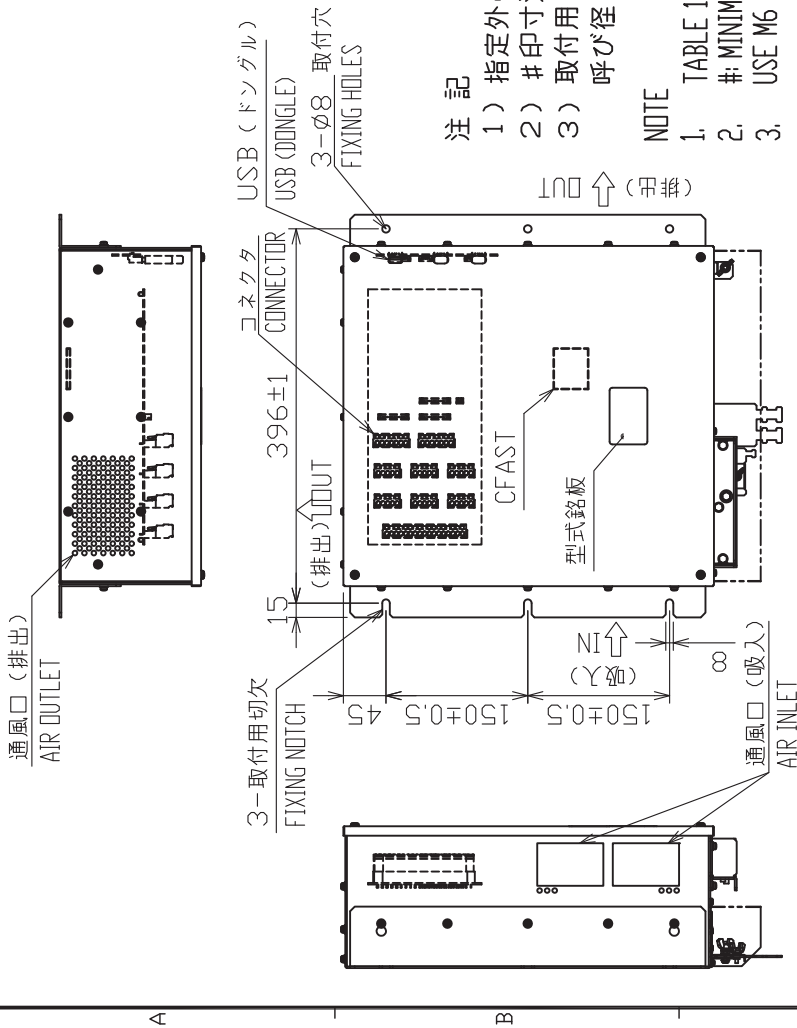

注 記

- 1) 指定外の寸法公差は表 1 による。
- 2) # 印寸法は最小サービスクリアランスとする。
- 3) 取付用ネジは M6 ボルトまたはコーチボルト呼び径 6 を使用のこと。

NOTE

1. TABLE 1 INDICATES TOLERANCE OF DIMENSIONS WHICH IS NOT SPECIFIED.
2. # MINIMUM SERVICE CLEARANCE.
3. USE M6 BOLTS OR COACH SCREWS φ6 FOR FIXING THE UNIT.

背面 (尺度: 1/12)
REAR VIEW (SCALE: 1/12)

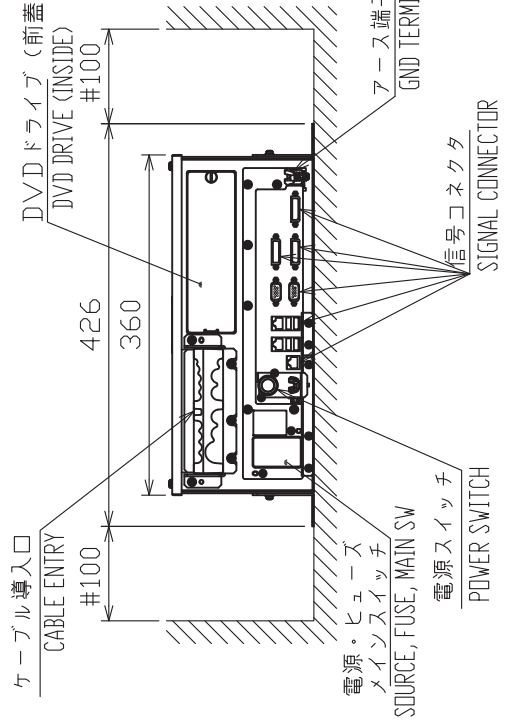
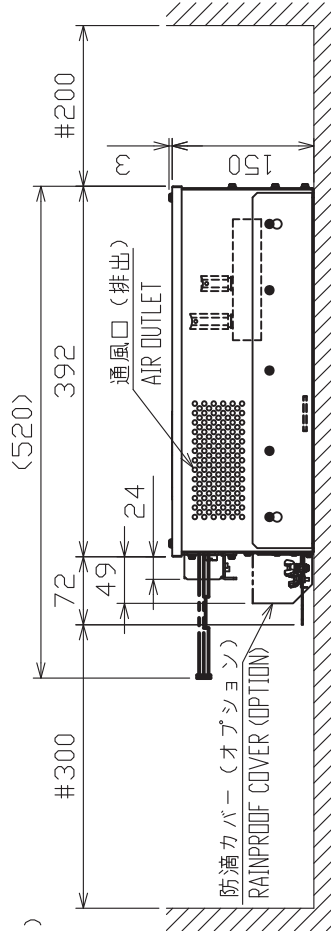

DRAWN	29/Nov/2017 T.YAMASAKI	TITLE	EC-3000
CHECKED	29/Nov/2017 H.MAKI	名称	制御部 (卓上装備)
APPROVED	29/Nov/2017 H.MAKI	外寸図	PROCESSOR UNIT (TABLETOP MOUNT)
SCALE	1/8	図名	OUTLINE DRAWING
FIG.No.	C4473-G14-B	REF.No.	24-014-010G-4

電源・信号ケーブル (5 m)

POWER/SIGNAL CABLE

USBケーブル

USB CABLE

308±0.5

取付穴

4-M4

FIXING HOLES

136±0.5

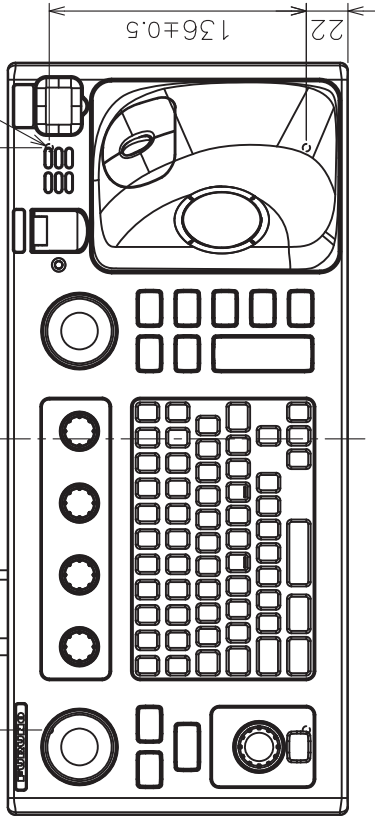

398

10

ネジ深さ

THREAD DEPTH

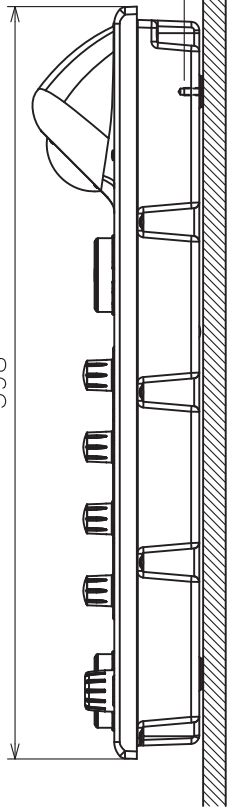

4-% 水抜穴

DRAIN HOLES

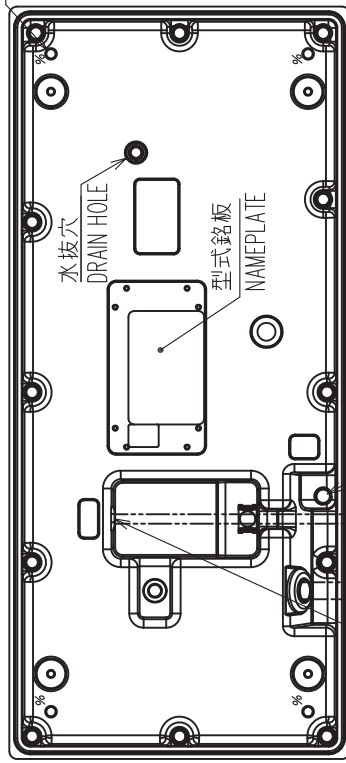

水抜穴

DRAIN HOLE

型式銘板

NAMEPLATE

信号コネクタ

SIGNAL CONNECTOR

アース端子

GND TERMINAL

表1 TABLE 1

寸法区分 (mm) DIMENSION	公差 (mm) TOLERANCE
L ≤ 50	±1.5
50 < L ≤ 100	±2.5
100 < L ≤ 500	±3

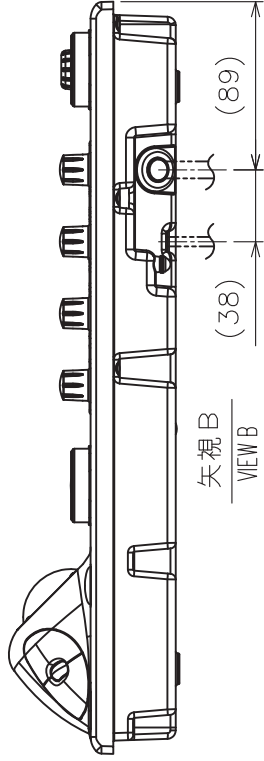

矢視 B

VIEW B

(38)

(89)

180

#70

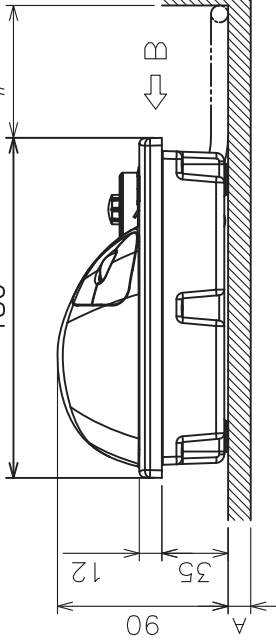

90

12

35

A

- 注記
- 1) 指定外の寸法公差は表1による。
 - 2) #印寸法は最小サージスペース寸法とする。
 - 3) 取付ネジはセムスネジB M4×12を使用のこと。
壁の厚さ(A)は最小2mm、最大4mmとする。
それ以外の場合は、M4×(A(壁の厚さ)+8±2mm)とする。
- NOTE
1. TABLE 1 INDICATES TOLERANCE OF DIMENSIONS WHICH IS NOT SPECIFIED.
 2. # MINIMUM SERVICE CLEARANCE.
 3. USE SEMS B SCREWS (M4x12) FOR BULKHEAD THICKNESS(A); 2 ≤ A ≤ 4 OR SCREW LENGTH: A+8±2.

DRAWN	6/Nov/2012	T.YAMASAKI	TITLE	RCU-024
CHECKED	6/Nov/2012	H.MAKI	名称	ECDIS操作部(卓上装備)
APPROVED	/Nov/2012	Y.NISHIYAMA	外寸図	
SCALE	1/4	質量 3.0 kg	NAME	ECDIS CONTROL UNIT (TABLETOP MOUNT)
DWG.No.	C4473-G02-B	REF.No.	24-014-100G-2	OUTLINE DRAWING

表1 TABLE 1

寸法区分 (mm) DIMENSION	公差 (mm) TOLERANCE
L ≤ 50	±1.5
50 < L ≤ 100	±2.5
100 < L ≤ 500	±3

電源・信号ケーブル (5 m)
POWER/SIGNAL CABLE

USBケーブル
USB CABLE

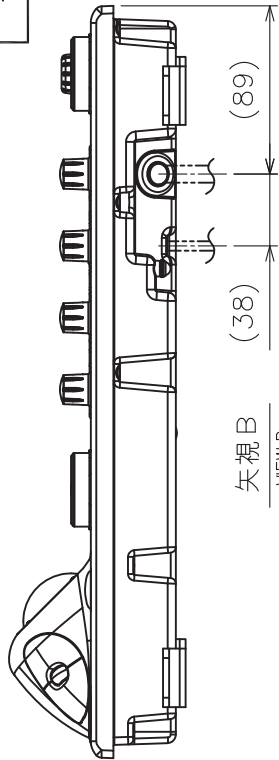
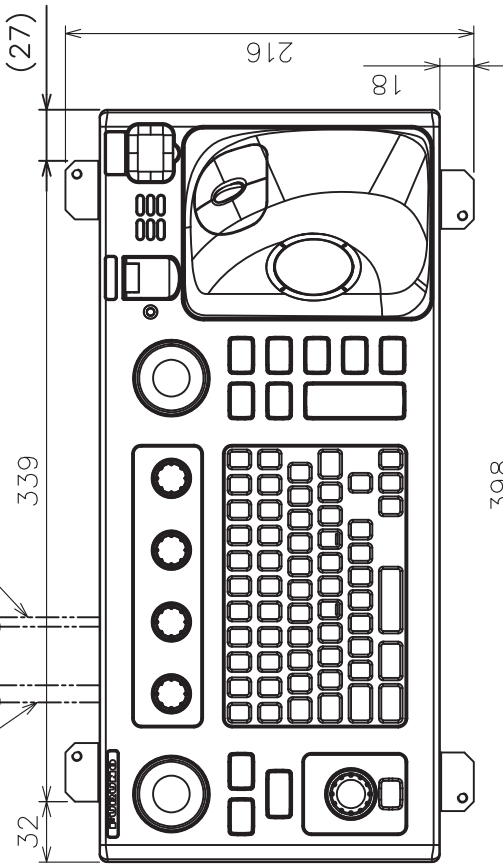

矢視 B
VIEW B

18

216

(27)

398

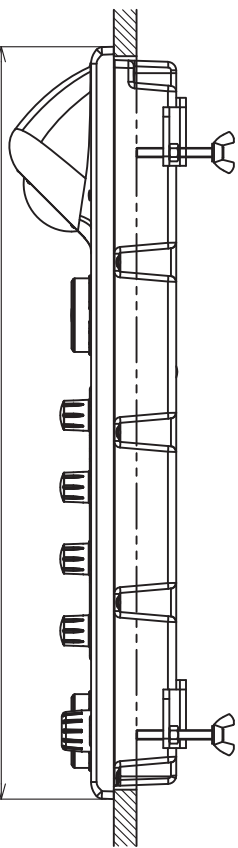

#70

180

矢視 B
VIEW B

55

70

180

18

矢視 B
VIEW B

(38)

(89)

398

UNIT LOCATION

本体位置

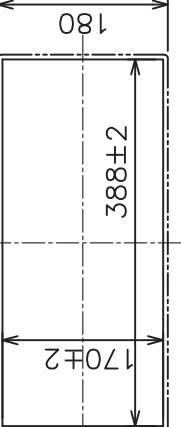

170±2

388±2

180

取付寸法 (尺度: 1/8)
CUTOUT DIMENSIONS (SCALE: 1/8)

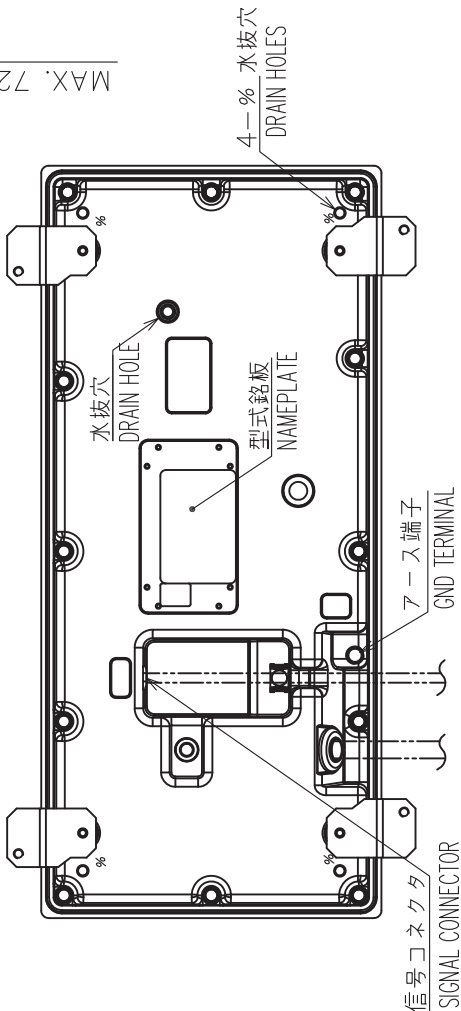

水抜穴
DRAIN HOLE

型式銘板
NAMEPLATE

4-φ 水抜穴
DRAIN HOLES

ース端子
GND TERMINAL

信号コネクタ
SIGNAL CONNECTOR

注記 1) 指定外の寸法公差は表1による。

2) #印寸法は最小サージス空間寸法とする。

3) 壁の厚さ(A)は最小10mm、最大20mmとする。

NOTE 1. TABLE 1 INDICATES TOLERANCE OF DIMENSIONS WHICH IS NOT SPECIFIED.

2. # MINIMUM SERVICE CLEARANCE.

3. BULKHEAD THICKNESS(A): 10 ≤ A ≤ 20

DRAWN	5/Nov/2012	T.YAMASAKI	TITLE	RCU-024
CHECKED	5/Nov/2012	H.MAKI	名称	ECDIS操作部 (埋込装備)
APPROVED	/Nov/2012	Y.NISHIYAMA	外寸図	
SCALE	1/4	質量 3.1 kg	質量は5mmケーブルを含む。	
DMC No.	C4473-G03-B	REF.No.	24-014-110G-2	



表1 TABLE 1

寸法区分 (mm) DIMENSION	公差 (mm) TOLERANCE
L ≤ 50	±1.5
50 < L ≤ 100	±2.5
100 < L ≤ 500	±3

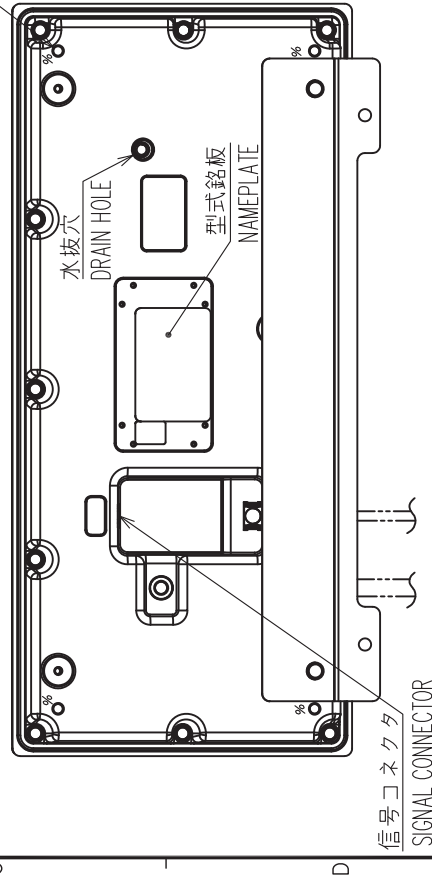
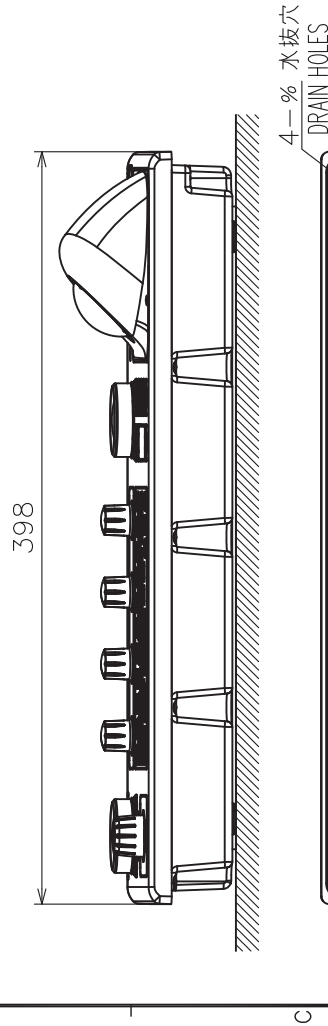
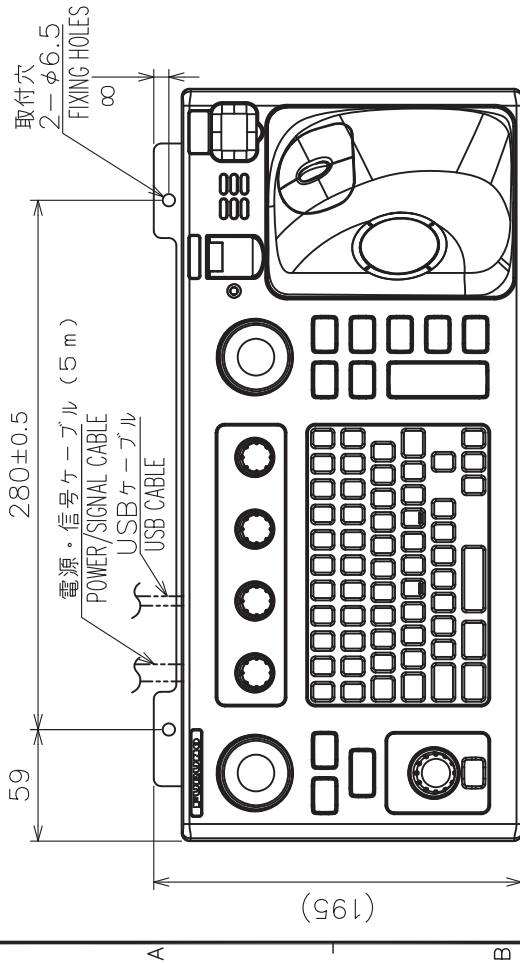
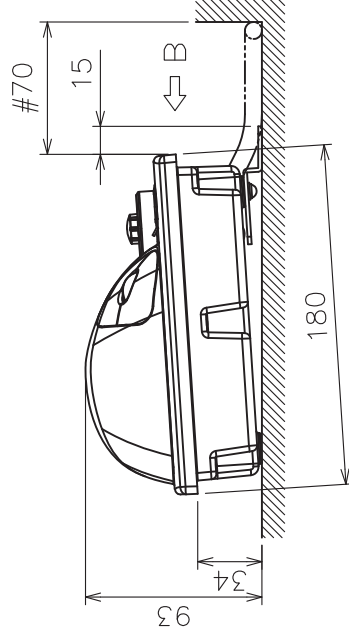
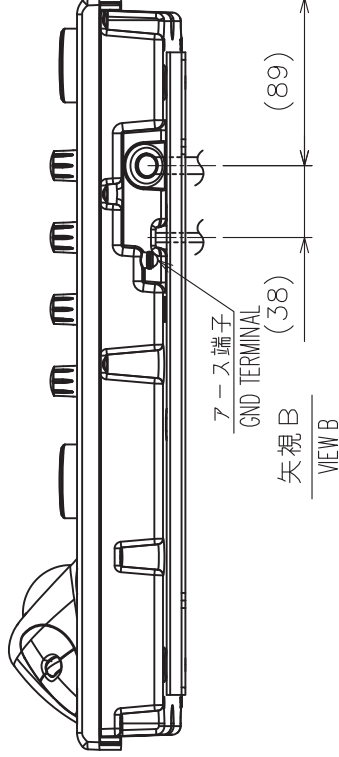

注記 1) 指定外の寸法公差は表1による。

2) #印寸法は最小サービスインスペーシングとする。

3) 取付ネジはトラスネジ呼び径5×20を使用のこと。

NOTE 1. TABLE 1 INDICATES TOLERANCE OF DIMENSIONS WHICH IS NOT SPECIFIED.

2. # MINIMUM SERVICE CLEARANCE.

3. USE TAPPING SCREWS φ5x20 FOR FIXING THE UNIT.

DRAWN	5/Nov/2012	T.YAMASAKI	TITLE	RCU-024
CHECKED	5/Nov/2012	H.MAKI	名称	ECDIS操作部 (取付金具)
APPROVED	7/Nov/2012	Y. NISHIYAMA	外寸図	
SCALE	1/4	質量は5mケーブルを含む。 ±0.4g 質量は5mケーブルを含む。 ±0.4g MASS INCLUDES 5m CABLE.	NAME	ECDIS CONTROL UNIT (FIXTURE MOUNT)
DWG.No.	C4473-G04-B	REF.No.	24-014-120G-2	OUTLINE DRAWING

表1 TABLE 1

寸法区分 (mm) DIMENSION	公差 (mm) TOLERANCE
L ≤ 50	±1.5
50 < L ≤ 100	±2.5
100 < L ≤ 500	±3

信号ケーブル
45 SIGNAL CABLE

信号電源ケーブル (5m)
POWER/SIGNAL CABLE (5m)

4-M4 取付穴
FIXING HOLES

308±1

136±1

22

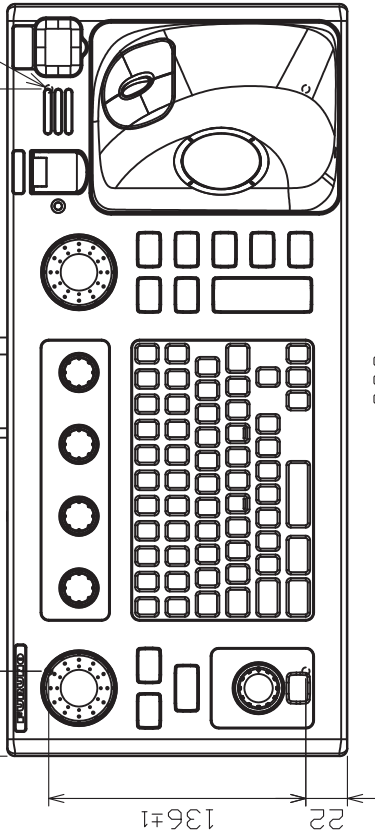

矢視B
VIEW B

(44)

(171)

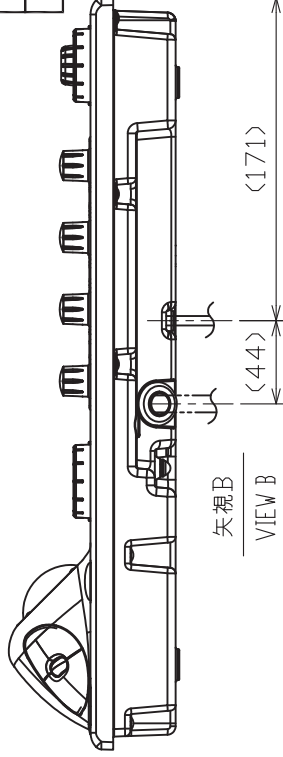

398

ネジ深さ10
THREAD DEPTH

90

12

35

#70

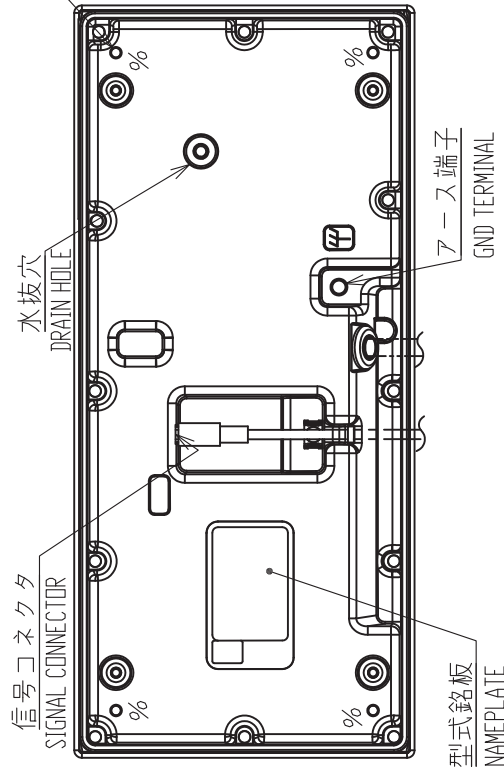
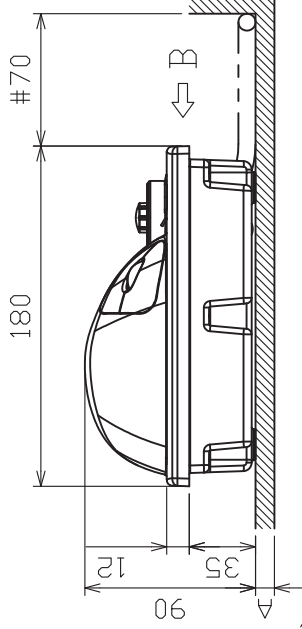
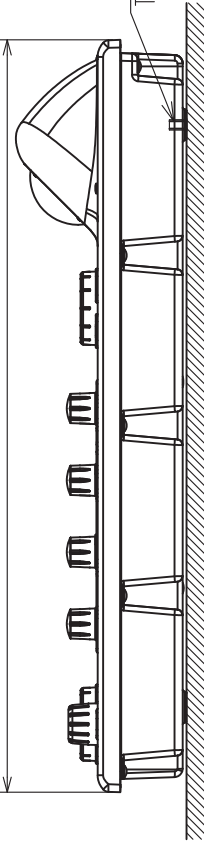

注記

- 1) 指定外の寸法公差は表1による。
- 2) #印寸法は最小サービス空間寸法とする。
- 3) 取付ネジはセムスネジB M4×12を使用のこと。
壁の厚さ(A)は最小2mm、最大4mmとする。
または、ネジ長さをA+8±2とする。

- NOTE
1. TABLE 1 INDICATES TOLERANCE OF DIMENSIONS WHICH IS NOT SPECIFIED.
 2. # MINIMUM SERVICE CLEARANCE.
 3. USE SEMS B SCREWS (M4x12) FOR BULKHEAD THICKNESS(A); 2 ≤ A ≤ 4 OR SCREW LENGTH: A+8±2.

DRAWN	10/Jan/2018	I.YAMASAKI	TITLE	RCU-024
CHECKED	10/Jan/2018	H.MAKI	名称	EC/DIS 操作部 (卓上装備)
APPROVED	11/Jan/2018	H.MAKI		外寸図
SCALE	1/4	100% 質量は5mケーブルを含む。 1kg MASS INCLUDES 5m CABLE.	NAME	EC/DIS CONTROL UNIT (TABLETOP MOUNT)
IMG.No.	C4473-G19-A	REF.No.	24-014-510G-1	OUTLINE DRAWING

信号ケーブル
SIGNAL CABLE

信号電源ケーブル (5m)
POWER/SIGNAL CABLE



表1 TABLE 1

寸法区分 (mm) DIMENSION	公差 (mm) TOLERANCE
$L \leq 50$	± 1.5
$50 < L \leq 100$	± 2.5
$100 < L \leq 500$	± 3

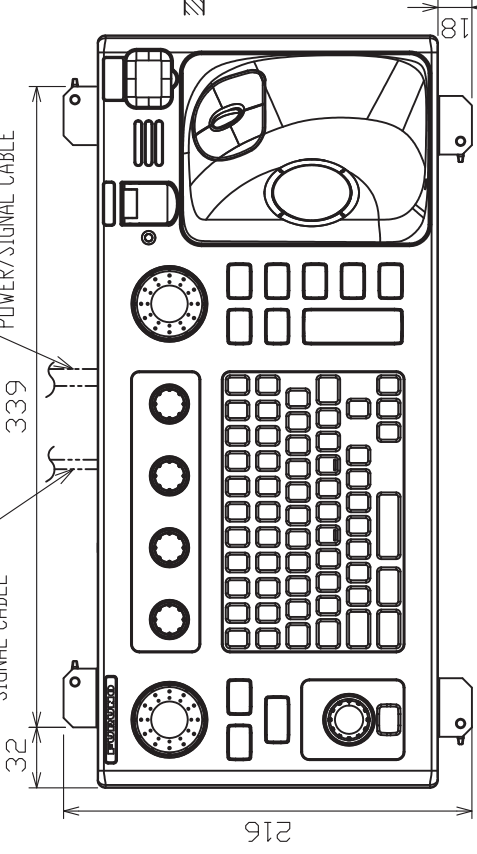
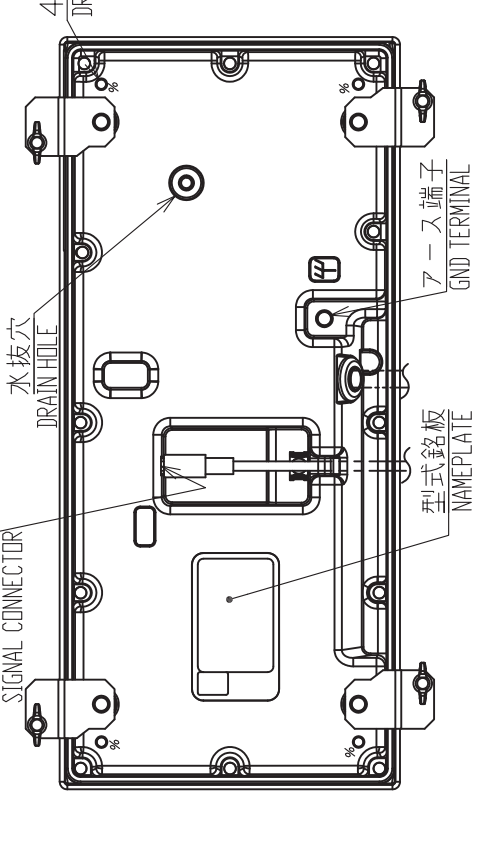
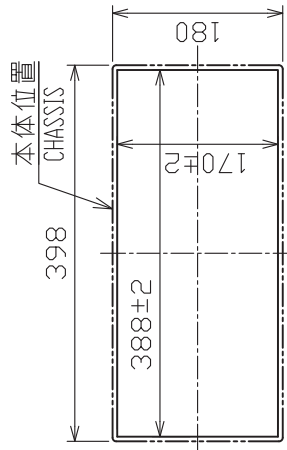
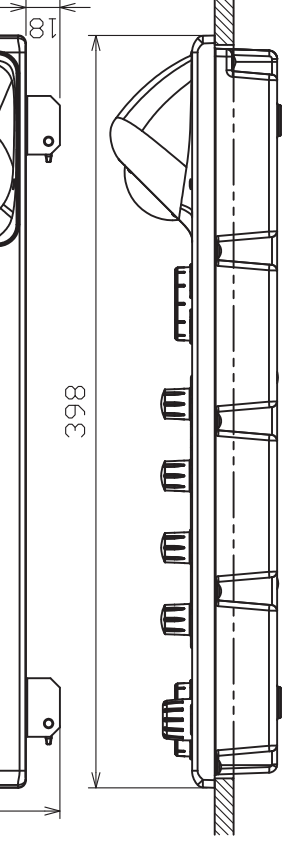
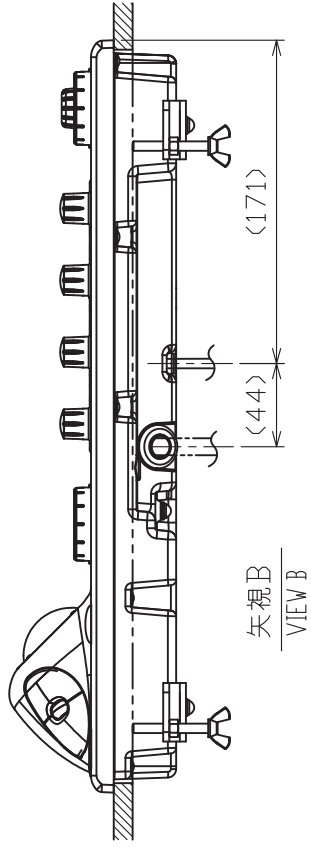

取付穴寸法 (尺度: 1/8)
CUTOUT DIMENSIONS (SCALE: 1/8)

- 注記
- 1) 指定外の寸法公差は表 1 による。
 - 2) # 印寸法は最小サービス空間寸法とする。
 - 3) 壁の厚さ (A) は最小10mm、最大20mmとする。
- NOTE
1. TABLE 1 INDICATES TOLERANCE OF DIMENSIONS WHICH IS NOT SPECIFIED.
 2. # MINIMUM SERVICE CLEARANCE.
 3. BULKHEAD THICKNESS(A): $10 \leq A \leq 20$.

DRAWN	10/Jan/2018	I.YAMASAKI	TITLE	RCU-024
CHECKED	10/Jan/2018	H.MAKI	名称	EC DIS 操作部 (埋込装備)
APPROVED	11/Jan/2018	H.MAKI	CD-3200/3300 EMD-3200/3300	外寸図
SCALE	1/4	質量 2.3 kg 10% 質量は5mケーブルを含む。 MASS INCLUDES 5m CABLE.	NAME	EC DIS CONTROL UNIT (FLUSH MOUNT)
IMG.No.	C4473-G18-A	REF.No.	24-014-500G-1	OUTLINE DRAWING

表1 TABLE 1

寸法区分 (mm) DIMENSION	公差 (mm) TOLERANCE
L ≤ 50	±1.5
50 < L ≤ 100	±2.5
100 < L ≤ 500	±3

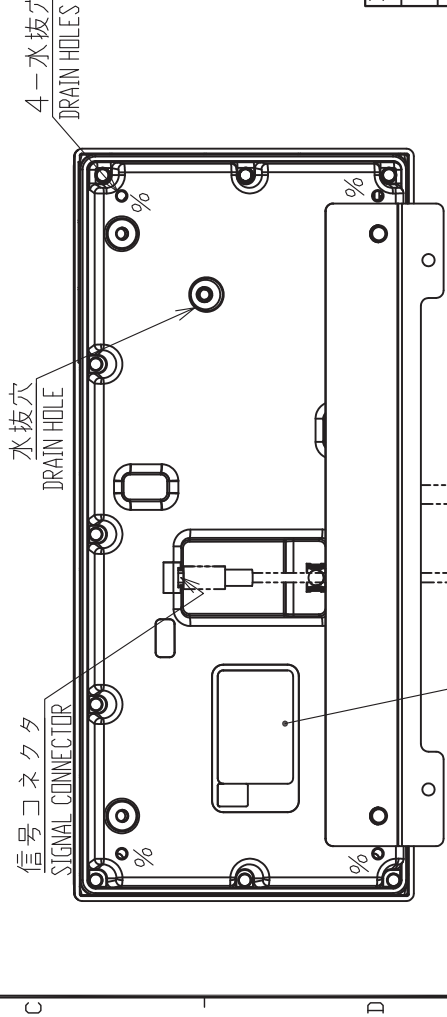
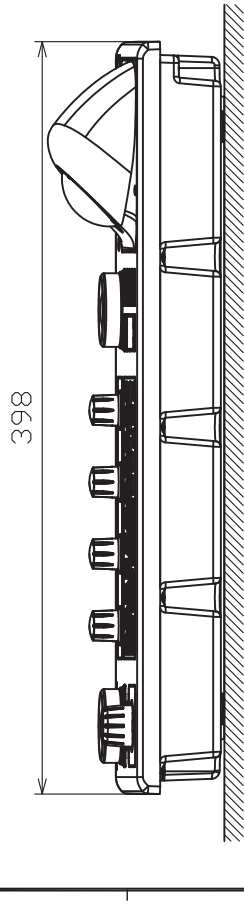
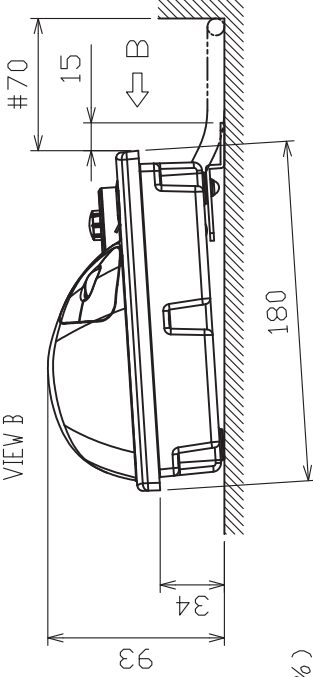
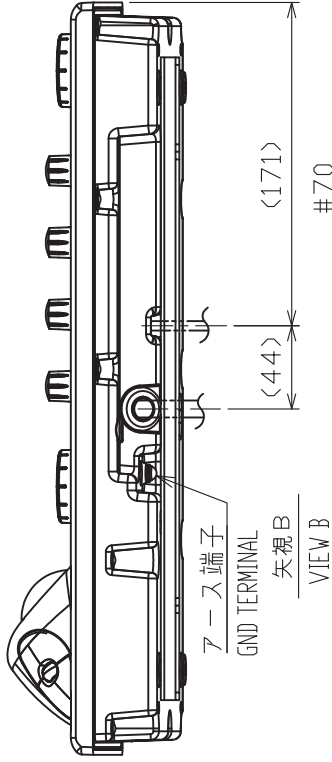
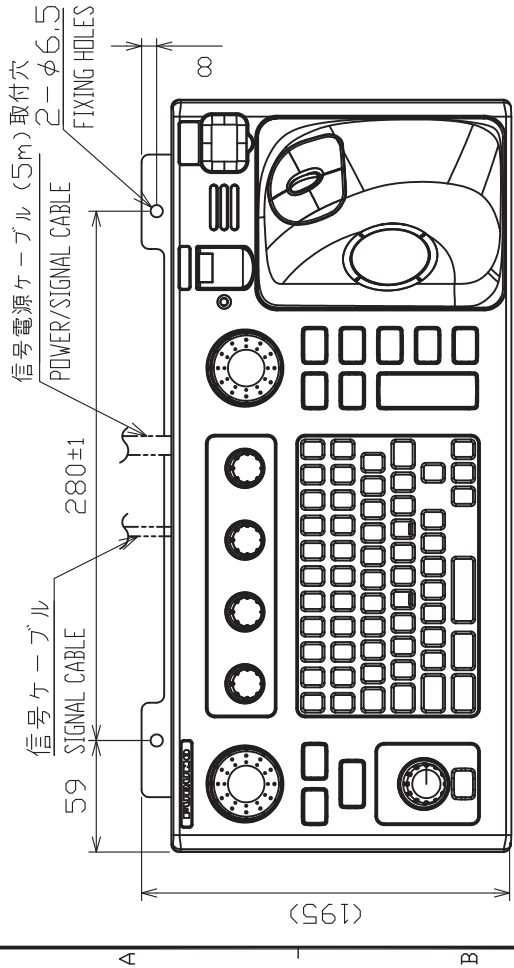

- 注記 1) 指定外の寸法公差は表 1 による。
 2) # 印寸法は最小サービス空間寸法とする。
 3) 壁の厚さ (A) は最小10mm、最大20mmとする。
- NOTE 1. TABLE 1 INDICATES TOLERANCE OF DIMENSIONS WHICH IS NOT SPECIFIED.
 2. # MINIMUM SERVICE CLEARANCE.
 3. BULKHEAD THICKNESS(A): 10 ≤ A ≤ 20.

DRAWN	10/Jan/2018	I.YAMASAKI	TITLE	RCU-024
CHECKED	10/Jan/2018	H.MAKI	名称	ECDIS 操作部 (取付金具)
APPROVED	11/Jan/2018	H.MAKI	外寸図	
SCALE	1/4	WSS 2.4	WME	ECDIS CONTROL UNIT (FIXTURE MOUNT)
IMG.No.	C4473-020-A	REF.No.	24-014-520G-1	OUTLINE DRAWING

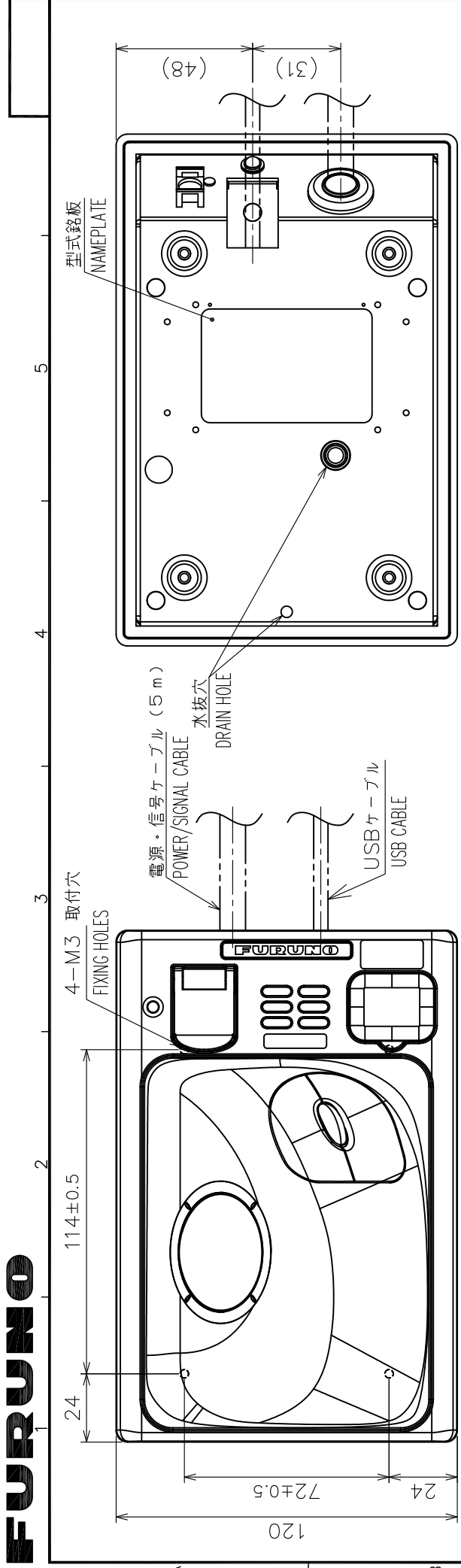

底面図
BOTTOM VIEW



表1 TABLE 1

寸法区分 (mm) DIMENSION	公差 (mm) TOLERANCE
L ≤ 50	±1.5
50 < L ≤ 100	±2.5
100 < L ≤ 500	±3

- 注記 1) 指定外の寸法公差は表1による。
 2) #印寸法は最小サービス空間寸法とする。
 3) 取付ネジはセムスネジ B M3×1.2を使用のこと。壁の厚さ(A)は最小2、最大4とする。それ以外はねじ長さをA+8±2とする。
- NOTE 1. TABLE 1 INDICATES TOLERANCE OF DIMENSIONS WHICH IS NOT SPECIFIED.
 2. # MINIMUM SERVICE CLEARANCE.
 3. USE SEMS B SCREWS M3x1.2 FOR BULKHEAD THICKNESS (A): 2 ≤ A ≤ 4. OR SCREW LENGTH: A+8±2.

DRAWN	14/Jun/2018	T. YAMASAKI	TITLE	RCU-026
CHECKED	14/Jun/2018	H. MAKI	名称	トラックボール操作部 (卓上装備)
APPROVED	14/Jun/2018	H. MAKI	外寸図	
SCALE	1/2	質量 1.4 kg 質量は5mケーブルを含む。 MASS INCLUDES 5m CABLE.	NAME	TRACKBALL CONTROL UNIT (TABLETOP MOUNT)
DWG.No.	C4473-G05-C	REF.No.	24-014-150G-2	OUTLINE DRAWING

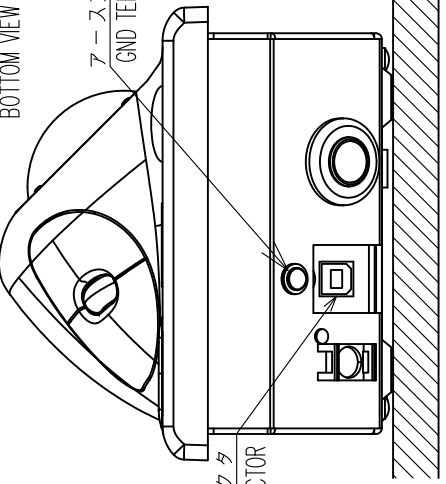
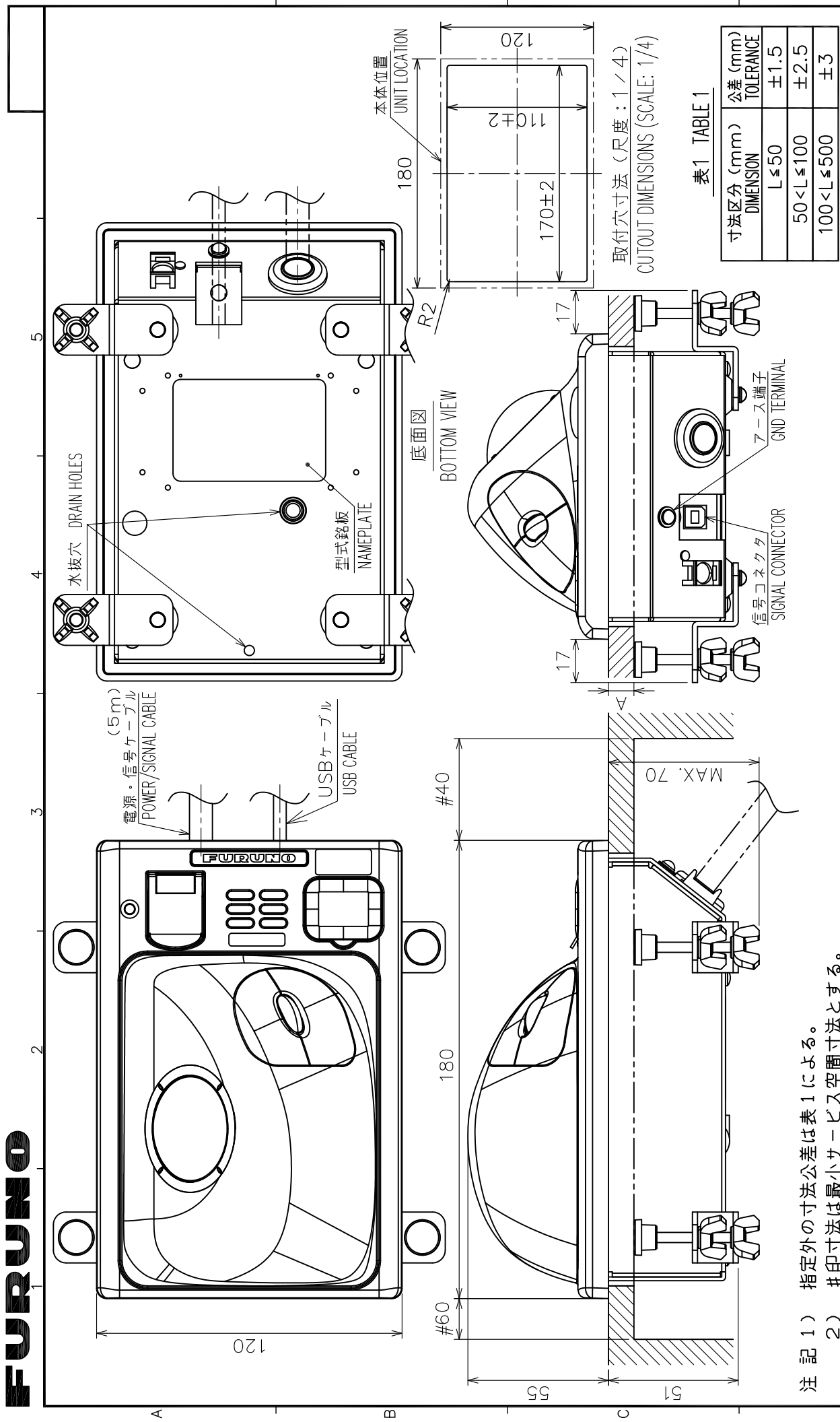

DRAWN	14/Jun/2018	T.YAMASAKI	TITLE	RCU-026
CHECKED	14/Jun/2018	H.MAKI	名称	トラックボール操作部 (埋込装備)
APPROVED	14/Jun/2018	H.MAKI	FMD-3200	外寸図
SCALE	1/2	MASS 1.5 kg	質量は5mケーブルを含む。 MASS INCLUDES 5m CABLE.	TRACKBALL CONTROL UNIT (FLUSH MOUNT)
DWG.No.	C4473-G06-C	REF.No.	24-014-160G-2	OUTLINE DRAWING

- 注記 1) 指定外の寸法公差は表1による。
 2) #印寸法は最小サージス空間寸法とする。
 3) 壁の厚さ(A)は最小10mm、最大20mmとする。
- NOTE 1. TABLE 1 INDICATES TOLERANCE OF DIMENSIONS WHICH IS NOT SPECIFIED.
 2. #: MINIMUM SERVICE CLEARANCE.
 3. BULKHEAD THICKNESS (A): 10 ≤ A ≤ 20.

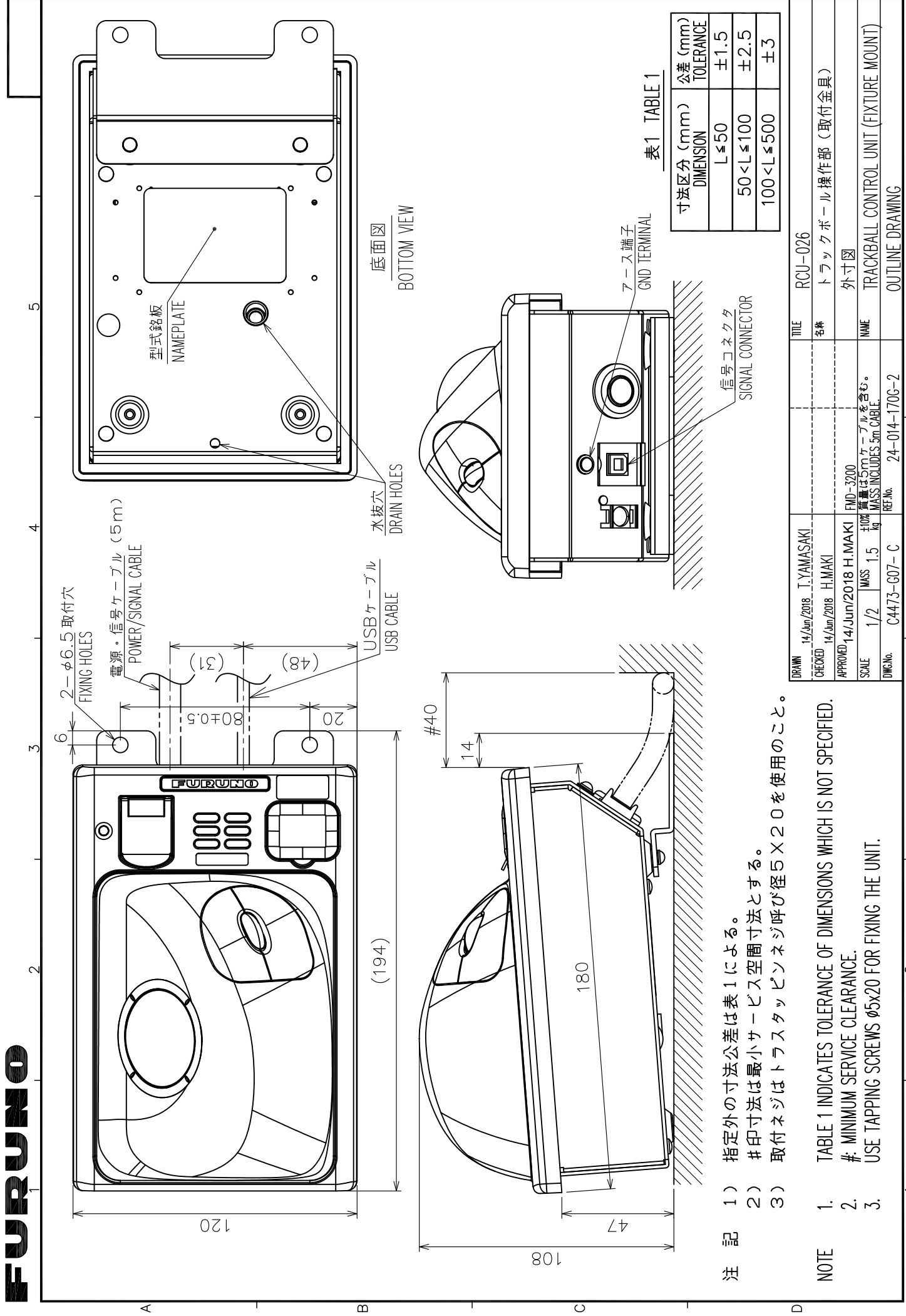

- 注記
- 1) 指定外の寸法公差は表1による。
 - 2) #印寸法は最小サービスクリアランスとする。
 - 3) 取付ネジはトラスタツピンネジ呼び径5×20を使用のこと。
- NOTE
1. TABLE 1 INDICATES TOLERANCE OF DIMENSIONS WHICH IS NOT SPECIFIED.
 2. #: MINIMUM SERVICE CLEARANCE.
 3. USE TAPPING SCREWS φ5x20 FOR FIXING THE UNIT.

DRAWN	14/Jun/2018	T. YAMASAKI	TITLE	RCU-026
CHECKED	14/Jun/2018	H. MAKI	名称	トラックボール操作部 (取付金具)
APPROVED	14/Jun/2018	H. MAKI	外寸図	
SCALE	1/2	質量 1.5 kg 質量は5mケーブルを含む。 ±10% MASS INCLUDES 5m CABLE.	NAME	TRACKBALL CONTROL UNIT (FIXTURE MOUNT)
DWG.No.	C4473-G07-C	REF.No.	24-014-170G-2	OUTLINE DRAWING



表1 TABLE 1

寸法区分 (mm) DIMENSION	公差 (mm) TOLERANCE
L ≤ 50	±1.5
50 < L ≤ 100	±2.5
100 < L ≤ 500	±3

- 注記 1) 指定外の寸法公差は表1による。
 2) #印寸法は最小サービス空間寸法とする。
 3) 取付用ネジはトラスタップネジ呼び径4×20を使用のこと。

- NOTE 1. TABLE 1 INDICATES TOLERANCE OF DIMENSIONS WHICH IS NOT SPECIFIED.
 2. #: MINIMUM SERVICE CLEARANCE.
 3. USE TAPPING SCREWS $\phi 4 \times 20$ FOR FIXING THE UNIT.

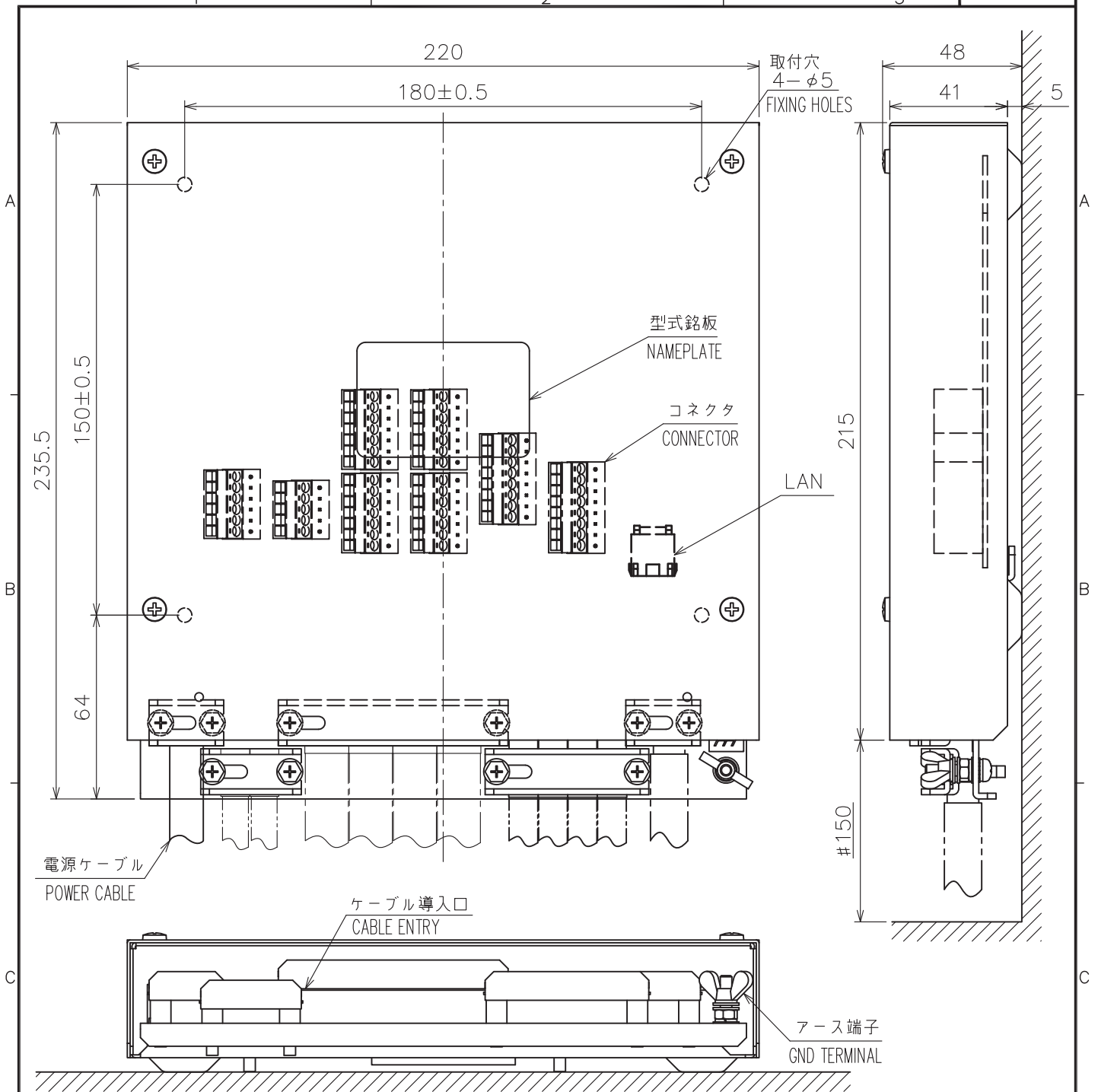
DRAWN	11/Jan/2012 T.YAMASAKI	TITLE	MC-3000S
CHECKED	11/Jan/2012 H.MAKI	名称	センサアダプター (シリアル)
APPROVED	13/Jan/2012 Y.NISHIYAMA	FMD-3200	外寸図
SCALE	1/2	MASS 1.5 ±10% kg	質量はケーブルを含まず。 MASS DOES NOT INCLUDE CABLE.
DWG. No.	C4473-G08-A	REF. No.	24-014-200G-1
		NAME	SENSOR ADAPTER (SERIAL)
			OUTLINE DRAWING



表1 TABLE 1

寸法区分 (mm) DIMENSION	公差 (mm) TOLERANCE
L ≤ 50	±1.5
50 < L ≤ 100	±2.5
100 < L ≤ 500	±3

- 注記 1) 指定外の寸法公差は表1による。
 2) #印寸法は最小サービス空間寸法とする。
 3) 取付用ネジはトラスタッピングネジ呼び径4×20を使用のこと。

- NOTE 1. TABLE 1 INDICATES TOLERANCE OF DIMENSIONS WHICH IS NOT SPECIFIED.
 2. #: MINIMUM SERVICE CLEARANCE.
 3. USE TAPPING SCREWS $\phi 4 \times 20$ FOR FIXING THE UNIT.

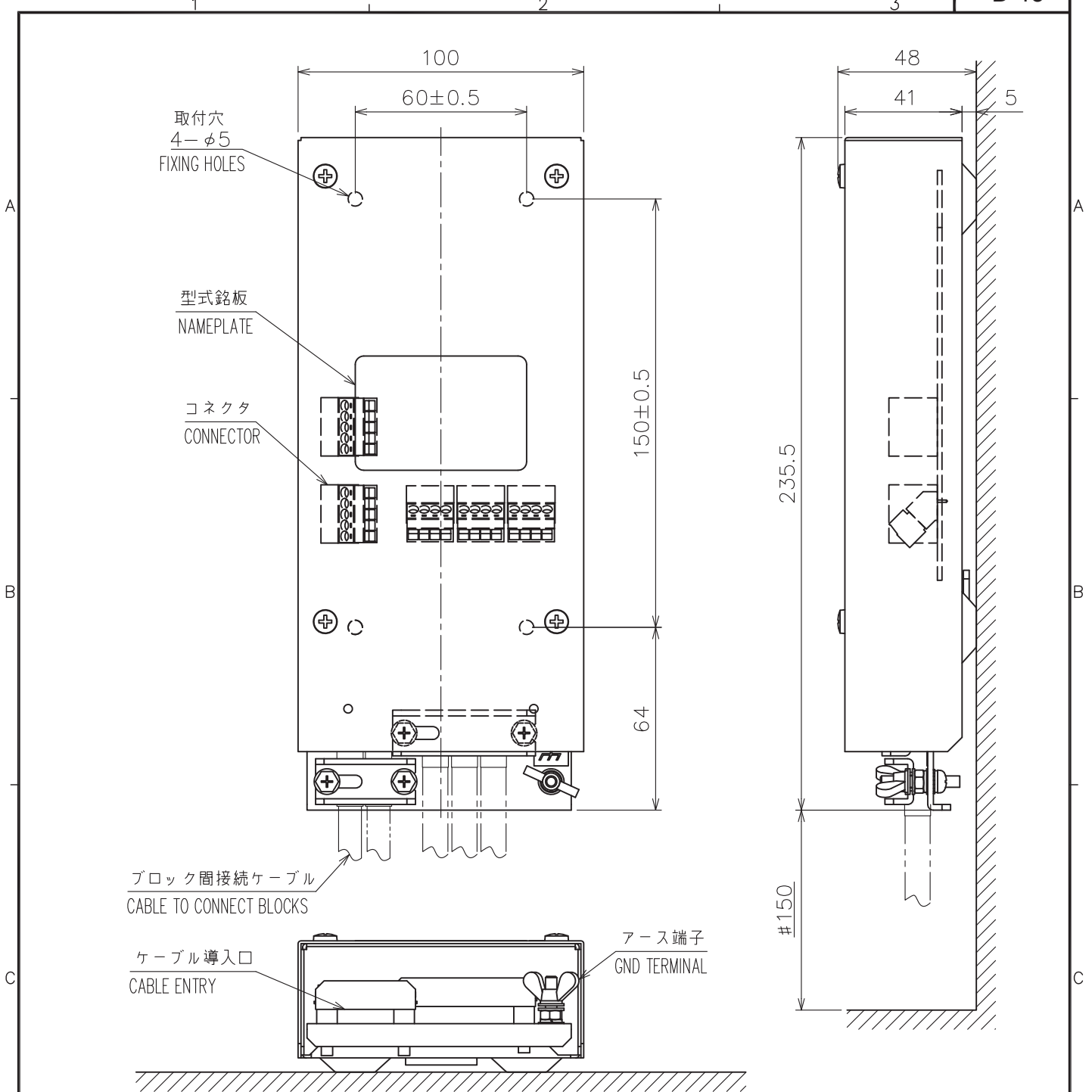
DRAWN 11/Jan/2012 T.YAMASAKI	TITLE MC-3010A
CHECKED 11/Jan/2012 H.MAKI	名称 センサーアダプター (アナログ)
APPROVED 13/Jan/2012 Y.NISHIYAMA	FMD-3200 外寸図
SCALE 1/2	MASS 0.8 ±10% 質量はケーブルを含まず。 MASS DOES NOT INCLUDE CABLE.
DWG. No. C4473-G09-A	REF. No. 24-014-210G-1
NAME SENSOR ADAPTER (ANALOG)	
OUTLINE DRAWING	



表1 TABLE 1

寸法区分 (mm) DIMENSION	公差 (mm) TOLERANCE
L ≤ 50	±1.5
50 < L ≤ 100	±2.5
100 < L ≤ 500	±3

- 注記 1) 指定外の寸法公差は表1による。
 2) #印寸法は最小サービス空間寸法とする。
 3) 取付用ネジはトラスタップピンネジ呼び径4×20を使用のこと。

- NOTE 1. TABLE 1 INDICATES TOLERANCE OF DIMENSIONS WHICH IS NOT SPECIFIED.
 2. #: MINIMUM SERVICE CLEARANCE.
 3. USE TAPPING SCREWS $\phi 4 \times 20$ FOR FIXING THE UNIT.

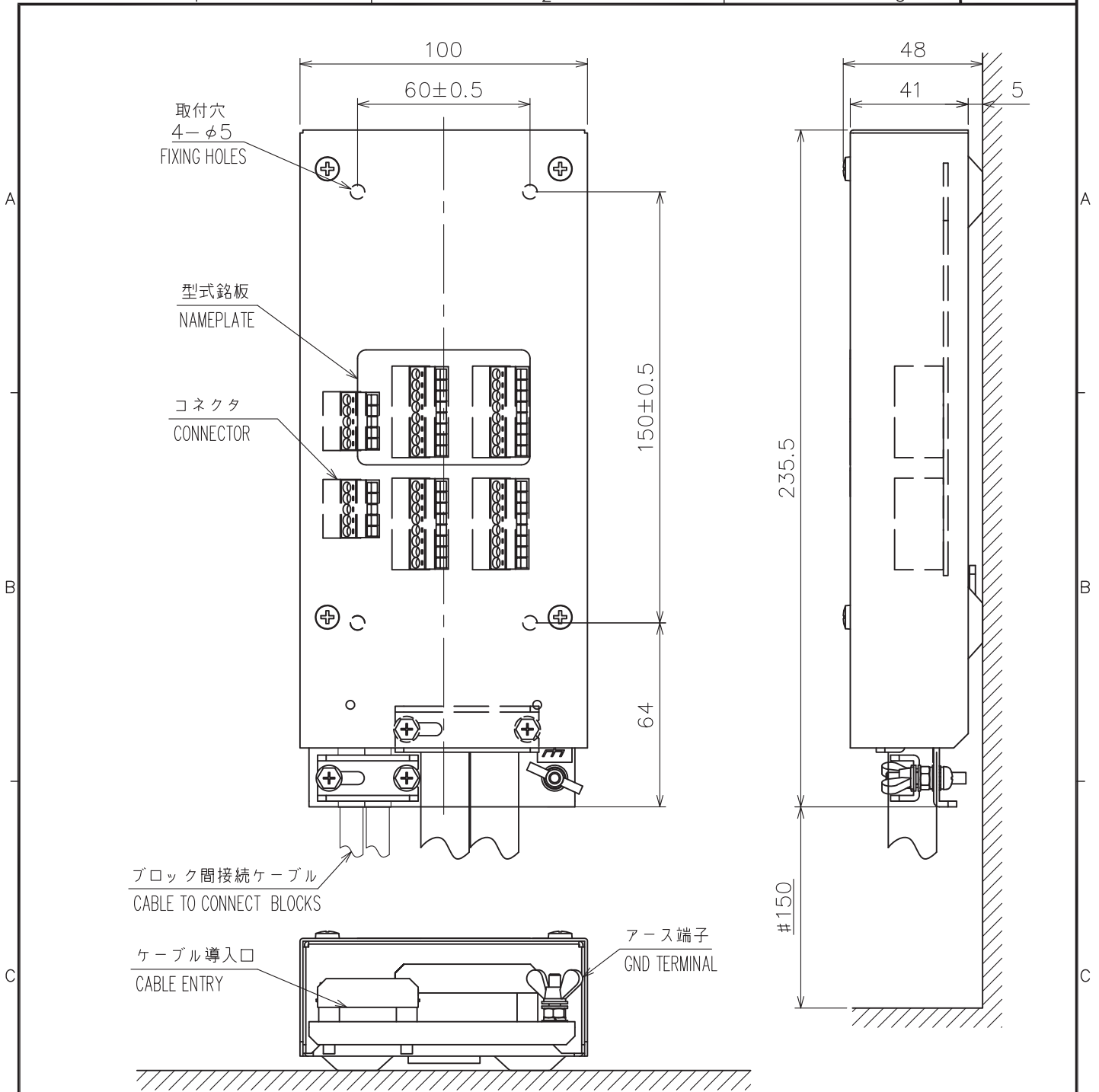
DRAWN 11/Jan/2012 I.YAMASAKI	TITLE MC-3020D
CHECKED 11/Jan/2012 H.MAKI	名称 センサーアダプター (デジタルイン)
APPROVED 13/Jan/2012 Y.NISHIYAMA	FMD-3200 外寸図
SCALE 1/2	MASS 0.8 ±10% kg 質量はケーブルを含まず。 MASS DOES NOT INCLUDE CABLE.
DWG. No. C4473-G10-A	REF. No. 24-014-220G-1
NAME SENSOR ADAPTER (DIGITAL IN)	
OUTLINE DRAWING	



表1 TABLE 1

寸法区分 (mm) DIMENSION	公差 (mm) TOLERANCE
L ≤ 50	±1.5
50 < L ≤ 100	±2.5
100 < L ≤ 500	±3

- 注記 1) 指定外の寸法公差は表1による。
 2) #印寸法は最小サービス空間寸法とする。
 3) 取付用ネジはトラスタップピンネジ呼び径4×20を使用のこと。

- NOTE 1. TABLE 1 INDICATES TOLERANCE OF DIMENSIONS WHICH IS NOT SPECIFIED.
 2. #: MINIMUM SERVICE CLEARANCE.
 3. USE TAPPING SCREWS $\phi 4 \times 20$ FOR FIXING THE UNIT.

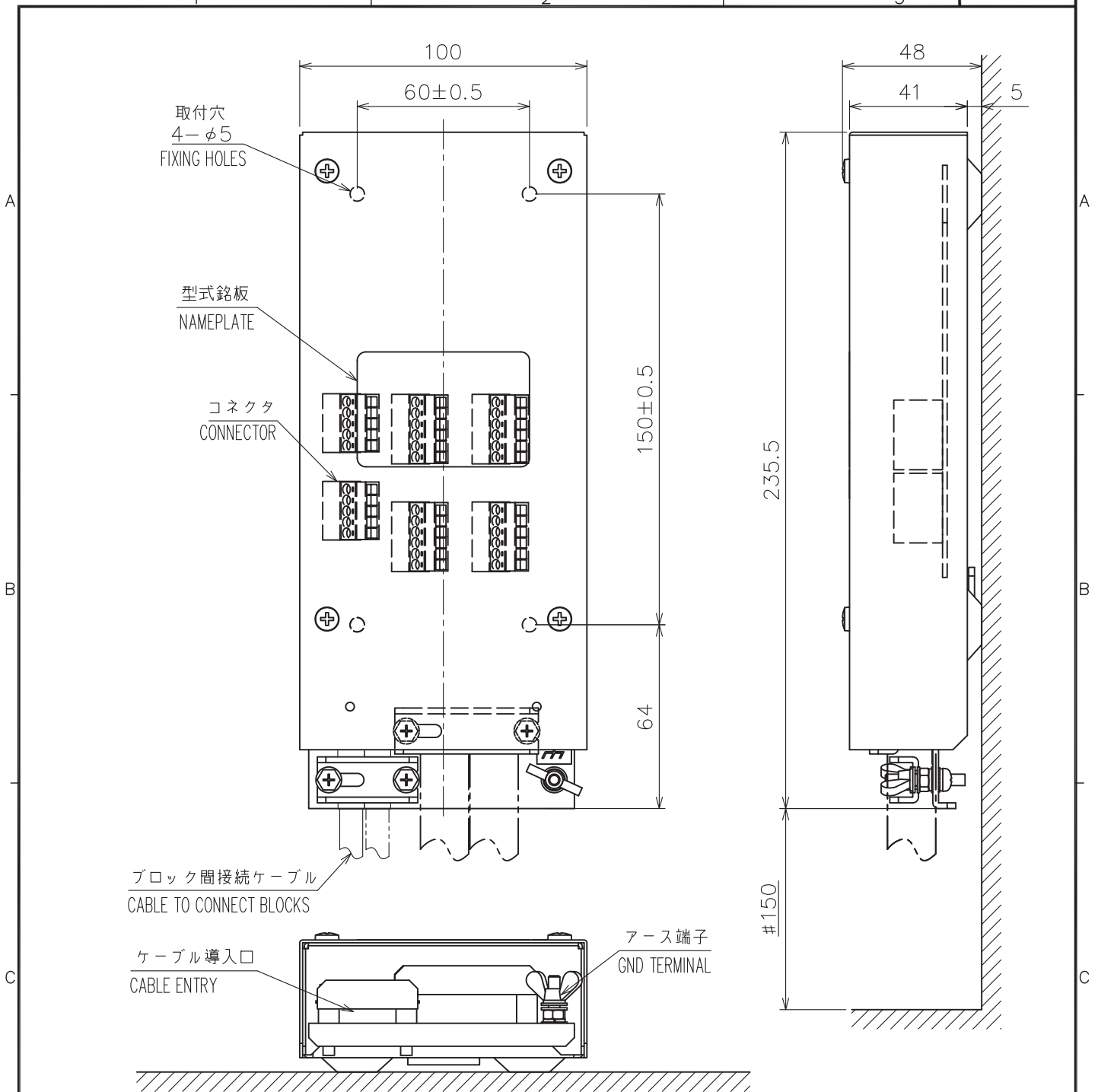
DRAWN 11/Jan/2012 T.YAMASAKI	TITLE MC-3030D
CHECKED 11/Jan/2012 H.MAKI	名称 センサーアダプター (デジタルアウト)
APPROVED 13/Jan/2012 Y.NISHIYAMA	FMD-3200 外寸図
SCALE 1/2	MASS 0.8 ±10% kg
質量はケーブルを含まず。 MASS DOES NOT INCLUDE CABLE.	
DWG. No. C4473-G11-A	NAME SENSOR ADAPTER (DIGITAL OUT)
REF. No. 24-014-230G-1	OUTLINE DRAWING

表1 TABLE 1

寸法区分 (mm) DIMENSION	公差 (mm) TOLERANCE
L ≤ 50	±1.5
50 < L ≤ 100	±2.5
100 < L ≤ 500	±3

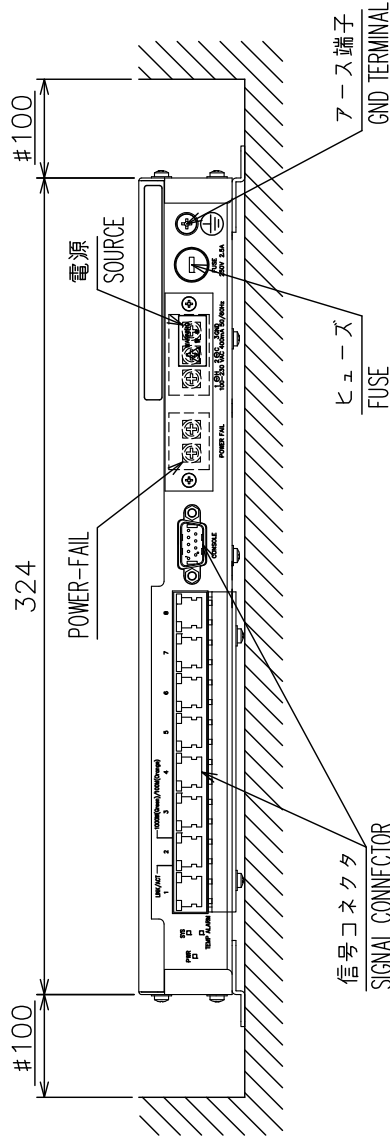
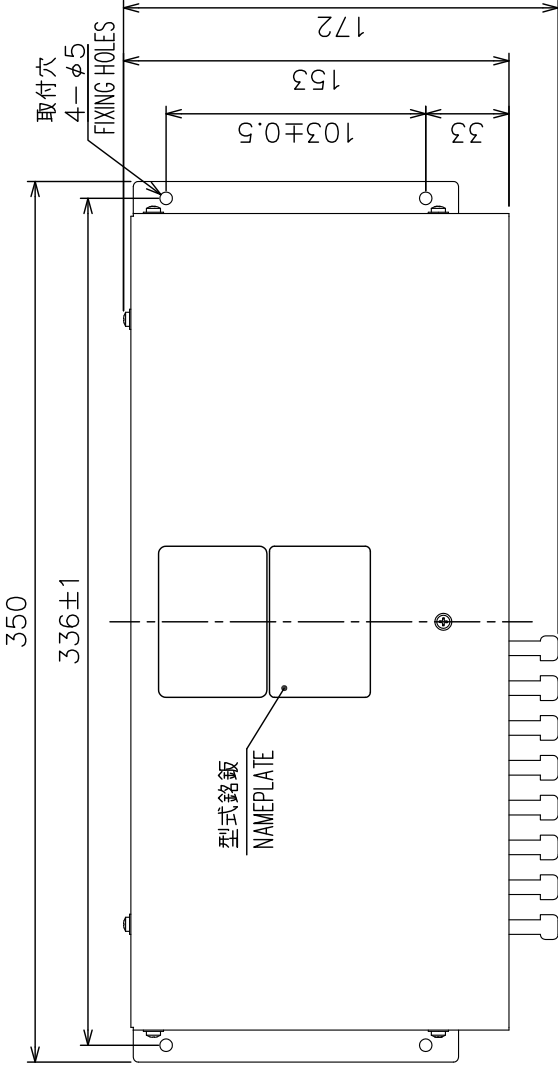
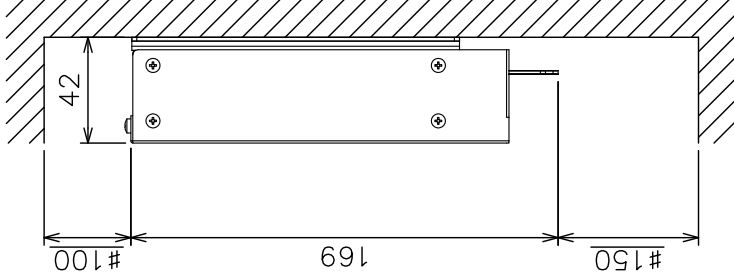

- 注記
- 1) 指定外の寸法公差は表1による。
 - 2) #印寸法は最小サービス空間寸法とする。
 - 3) 取付用ネジはトラスタックピンネジ呼び径4×20を使用のこと。
- NOTE
1. TABLE 1 INDICATES TOLERANCE OF DIMENSIONS WHICH IS NOT SPECIFIED.
 2. # MINIMUM SERVICE CLEARANCE.
 3. USE TAPPING SCREWS $\phi 4 \times 20$ FOR FIXING THE UNIT.

DRAWN	8/Jun/2018	T.YAMASAKI	TITLE	HUB-3000
CHECKED	8/Jun/2018	H.MAKI	名称	インテリジェントハブ
APPROVED	8/Jun/2018	H.MAKI	外寸図	
SCALE	1/3	1/MS 1.5 kg	NAME	INTELLIGENT HUB
DWG. No.	C4473-G12-C		REF. No.	24-014-350G-2

表1 TABLE 1

寸法区分 (mm) DIMENSION	公差 (mm) TOLERANCE
$L \leq 50$	± 1.5
$50 < L \leq 100$	± 2.5
$100 < L \leq 500$	± 3

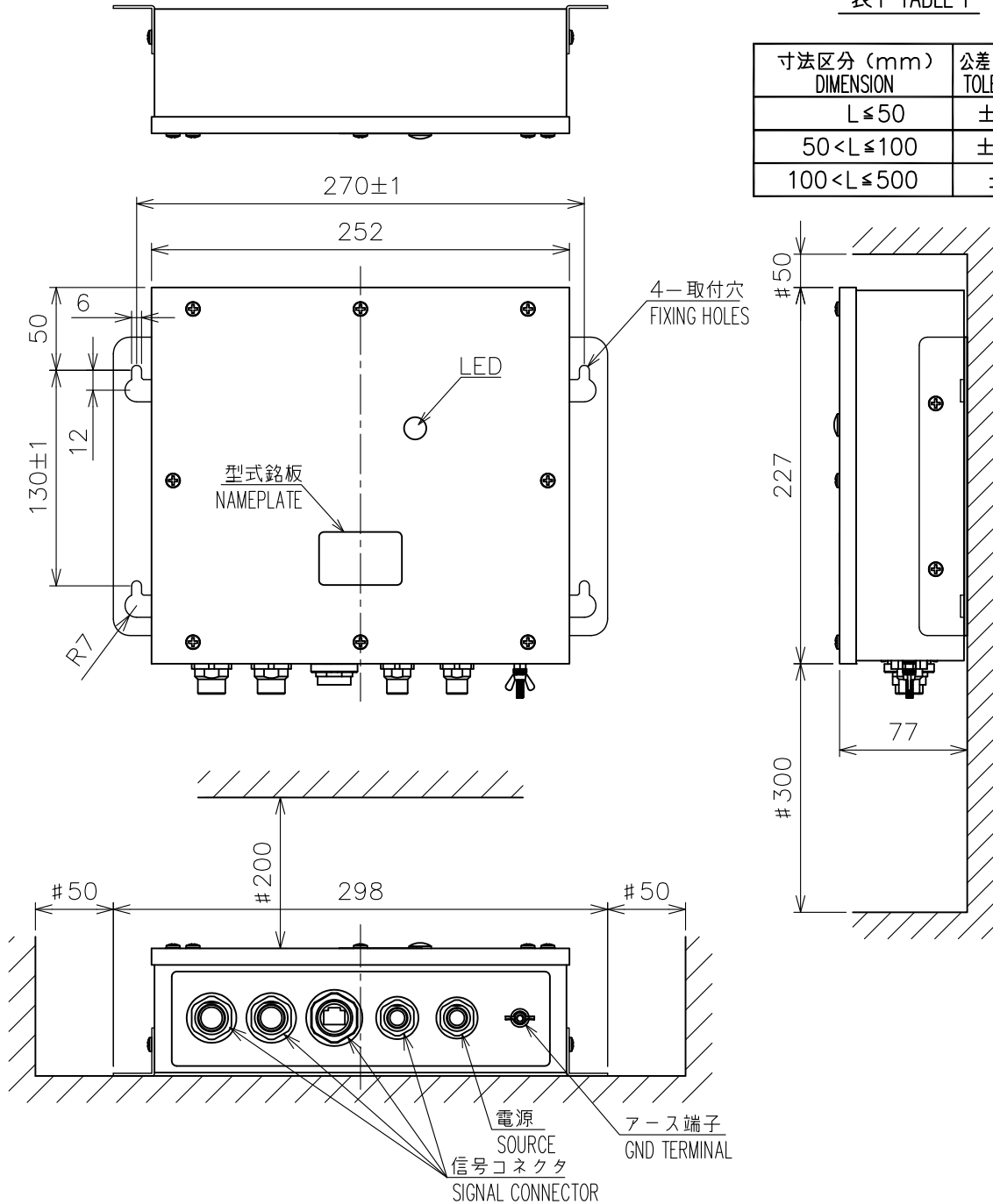

- 注 記
- 1) 指定外の寸法公差は表1による。
 - 2) #印寸法は最小サービス空間寸法とする。
 - 3) 取付用ネジはトラスタッピンネジ呼び径5×20を使用のこと。
 - 4) 壁掛装備は、必ずコネクタが下方となるよう取付けること。

- NOTE
1. TABLE 1 INDICATES TOLERANCE OF DIMENSIONS WHICH IS NOT SPECIFIED.
 2. #: MINIMUM SERVICE CLEARANCE.
 3. USE TAPPING SCREWS $\phi 5 \times 20$ FOR FIXING THE UNIT.
 4. FOR BULKHEAD MOUNT, FACE THE CONNECTORS DOWNWARD.

DRAWN 22/Aug/2019 T.YAMASAKI		TITLE RCB-002/002A
CHECKED 22/Aug/2019 H.MAKI		名称 レーダー接続箱 (壁掛・卓上装備)
APPROVED 22/Aug/2019 H.MAKI	KQ-900 FMD-3100	外寸図
SCALE 1/4	MASS 3.0 $\pm 10\%$ kg	NAME RADAR CONNECTION BOX (BULKHEAD/ TABLETOP MOUNT)
DWG. No. C4484-G03-C	REF. No. 24-016-130G-1	OUTLINE DRAWING

表1 TABLE 1

寸法区分 (mm) DIMENSION	公差 (mm) TOLERANCE
$L \leq 50$	± 1.5
$50 < L \leq 100$	± 2.5
$100 < L \leq 500$	± 3
$500 < L \leq 1000$	± 4
$1000 < L \leq 2000$	± 5

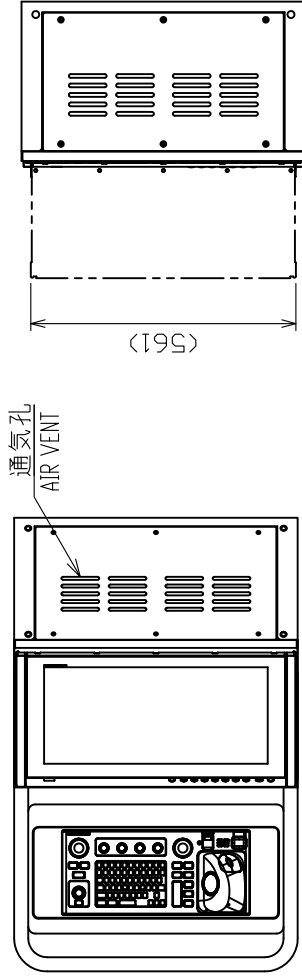

取外し量 120 (FOR REMOUNT)
フード (オプション) HOOD (OPTION)
矢視 B VIEW B

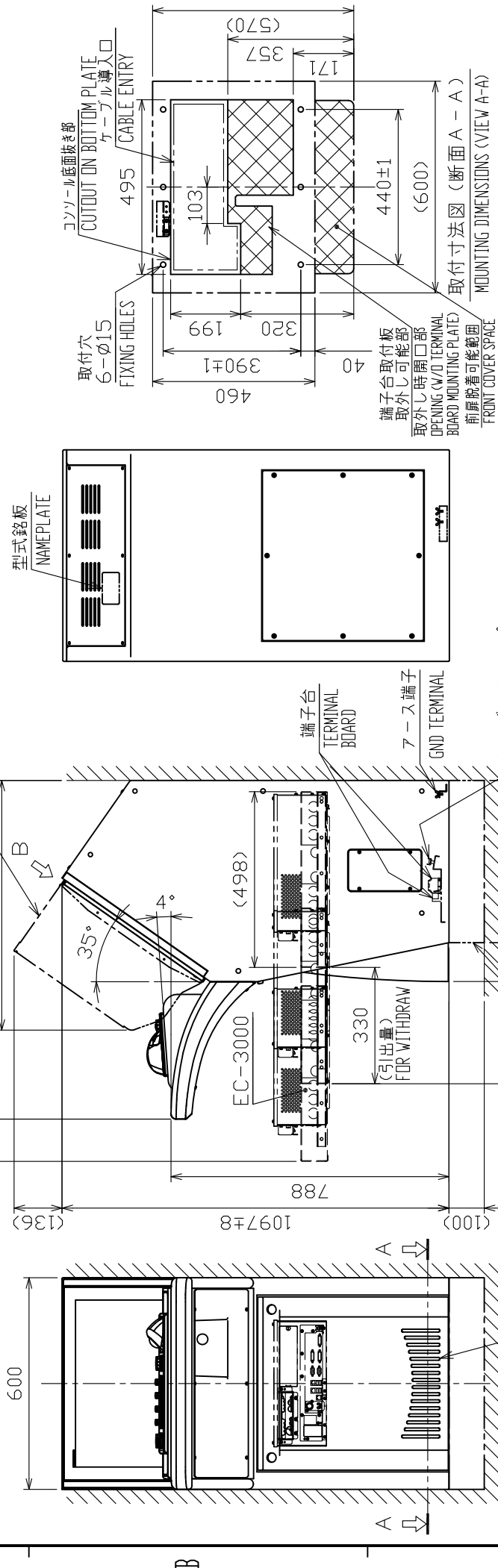

取付穴 6-φ15
FIXING HOLES

端子台取付板
取外し可能部
OPENING (W/O TERMINAL
BOARD MOUNTING PLATE)

取付寸法図 (断面 A-A)
MOUNTING DIMENSIONS (VIEW A-A)

CONSOLE 前面抜き部
CABLE ENTRY

型式銘板
NAMEPLATE

端子台
TERMINAL BOARD

アース端子
GND TERMINAL

ケーブルクランプ
CABLE CLAMP

通気孔
AIR VENT

チャンネルベース
CHANNEL BASE

- 注記
- 1) 指定外の寸法公差は表1による。
 - 2) 取付用ネジはM12ボルトを使用のこと。(SHIPYARD SUPPLY)
 - 3) 質量は下記の組ユニットを含む。
- NOTE
1. TABLE 1 INDICATES TOLERANCE OF DIMENSIONS WHICH IS NOT SPECIFIED.
 2. USE M12 BOLTS FOR FIXING THE UNIT.
 3. MASS INCLUDES CONFIGURATIONS SHOWN BELOW.

DRAWN	1/Apr/2021	I.YAMASAKI	TITLE	ECN-303
CHECKED	1/Apr/2021	H.MAKI	名称	スタンダードコンソール
APPROVED	6/Apr/2021	H.MAKI	外寸図	FMD-3300
SCALE	1/16	MASS 146 ±0.2 kg	NAME	STANDARD CONSOLE
FIG.No.	C4475-601-C	REF.No.	24-014-310G-3	OUTLINE DRAWING

表1 TABLE 1

寸法区分 (mm) DIMENSION	公差 (mm) TOLERANCE
L ≤ 50	±1.5
50 < L ≤ 100	±2.5
100 < L ≤ 500	±3
500 < L ≤ 1000	±4
1000 < L ≤ 2000	±5

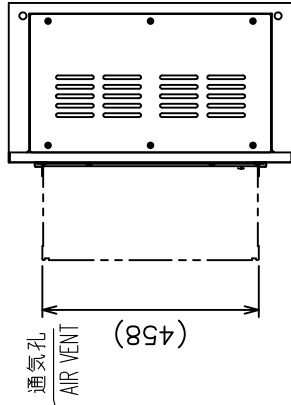

矢視 B
VIEW B

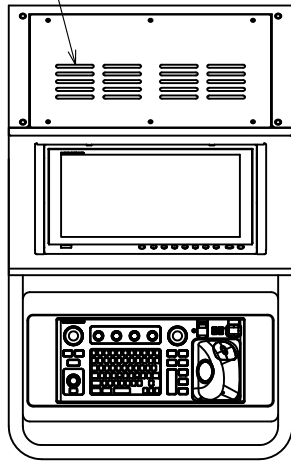
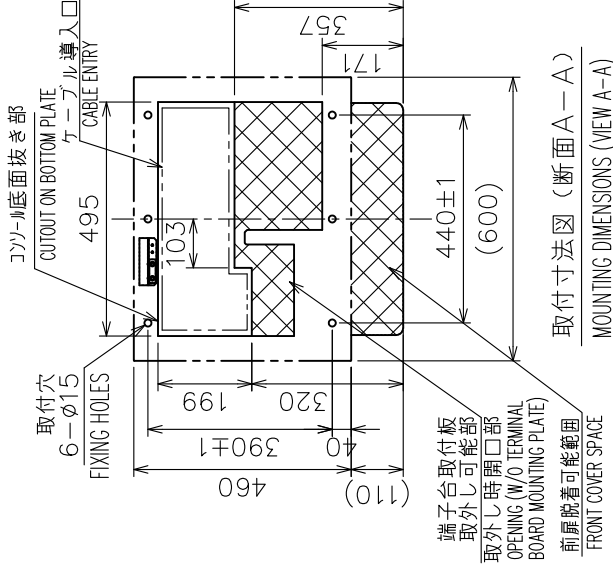
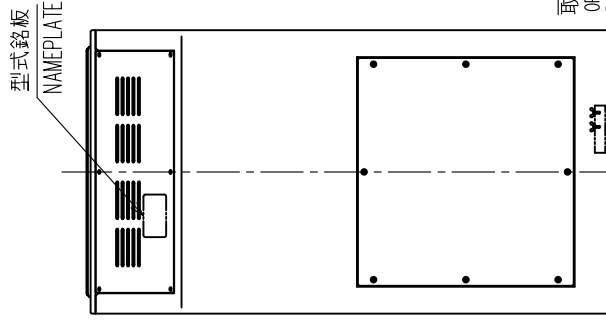

(1194)

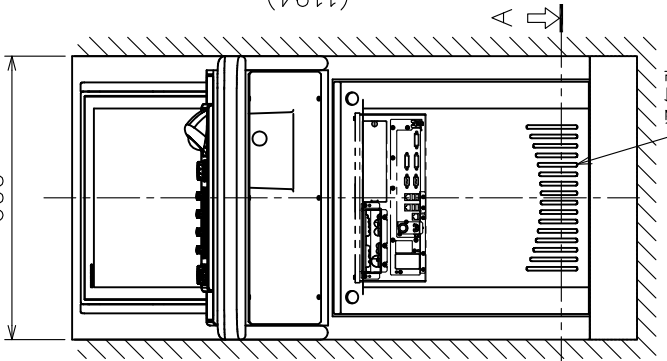

注記

- 指定外の寸法公差は表1による。
 - 取付用ネジはM12ボルトを使用のこと。
 - 質量はEC-3000、RCU-024、MU-190、HUB-100、HUB-3000、PR-241、MC-3000S、MC-3010Aを含む。
- NOTE
- TABLE 1 INDICATES TOLERANCE OF DIMENSIONS WHICH IS NOT SPECIFIED.
 - USE M12 BOLTS FOR FIXING THE UNIT.
 - MASS INCLUDE EC-3000, RCU-024, MU-190, HUB-100, HUB-3000, PR-241, MC-3000S, MC-3010A.

DRAWN	1/Apr/2021	I.YAMASAKI	TITLE	ECN-304
CHECKED	1/Apr/2021	H.MAKI	名称	スタンダードコンソール
APPROVED	6/Apr/2021	H.MAKI	外寸図	
SCALE	1/16	MASS 142	NAME	STANDARD CONSOLE
DWG.No.	C4473-G13-B	REF.No.	24-014-311G-2	OUTLINE DRAWING

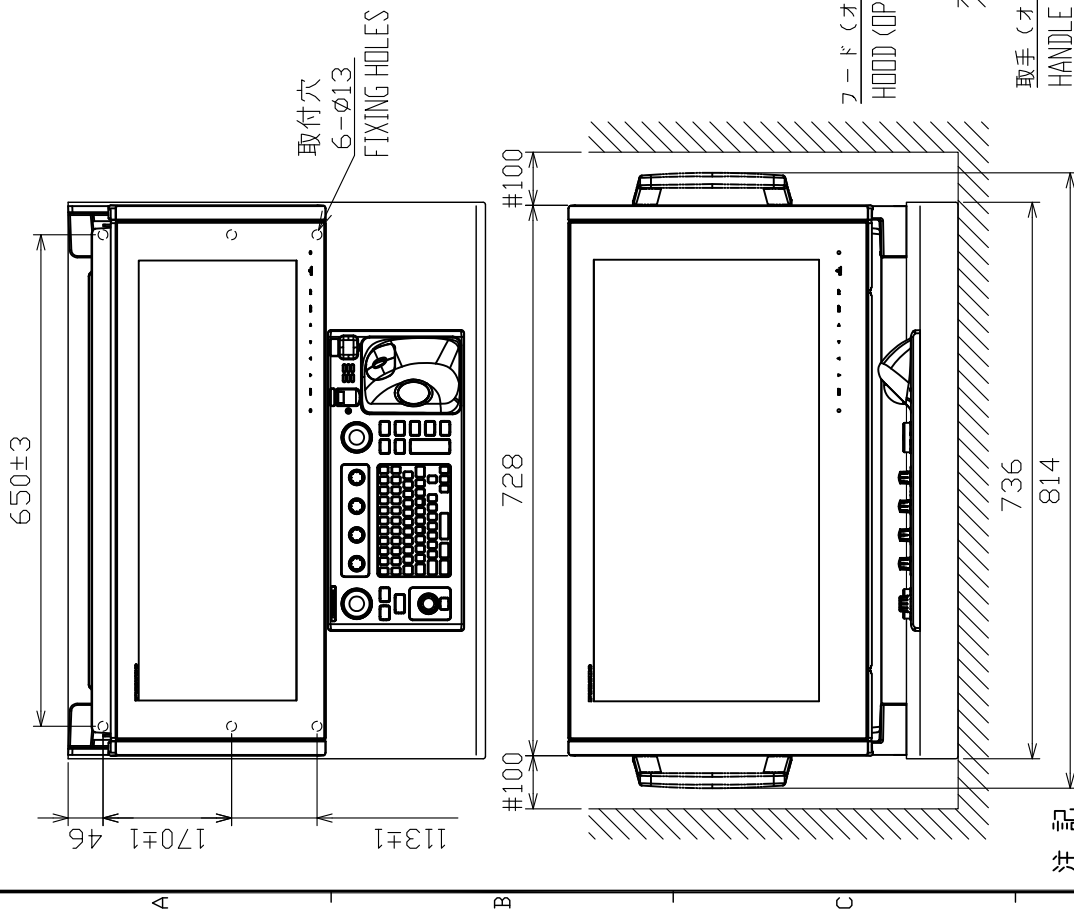

注記

- 1) 指定外の寸法公差は表1による。
- 2) #印寸法は最小サービス空間寸法とする。
- 3) 取付用ネジはM10ボルトまたはコーチボルト呼び径9を使用のこと。

NOTE

1. TABLE 1 INDICATES TOLERANCE OF DIMENSIONS WHICH IS NOT SPECIFIED.
2. # MINIMUM SERVICE CLEARANCE.
3. USE M10 BOLTS OR COARCH SCREWS #9 FOR FIXING THE UNIT.

表1 TABLE 1

寸法区分 (mm) DIMENSION	公差 (mm) TOLERANCE
L ≤ 50	±1.5
50 < L ≤ 100	±2.5
100 < L ≤ 500	±3
500 < L ≤ 1000	±4

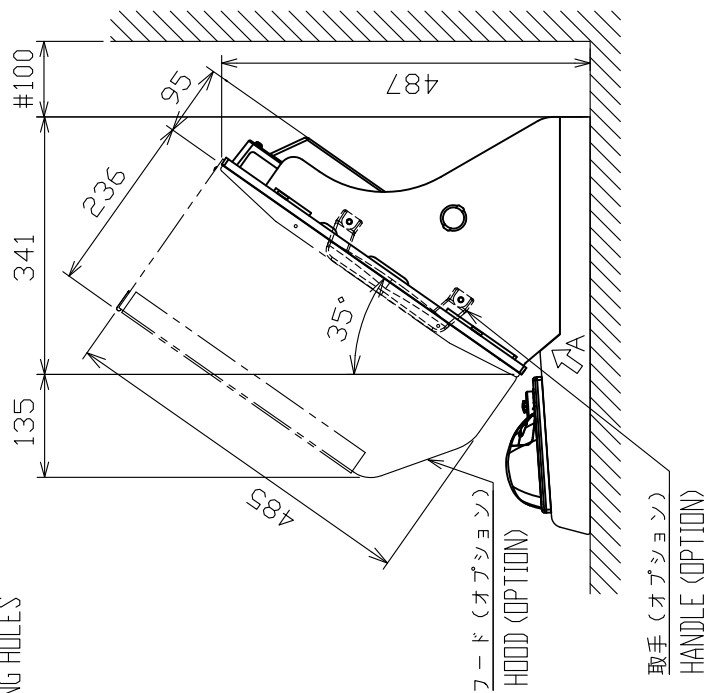
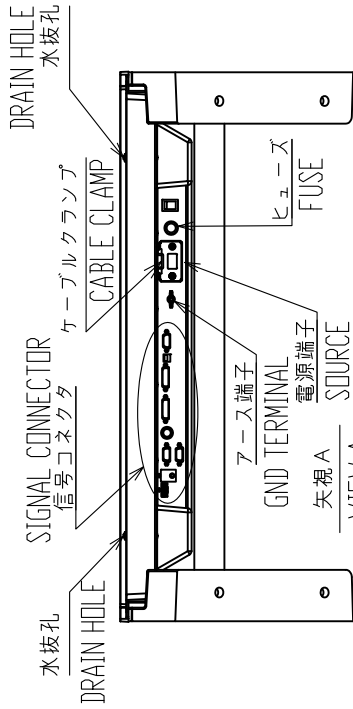

DRAWN 3/Feb/2020 LYAMASAKI	TITLE MU-270W
CHECKED 3/Feb/2020 HMAKI	名称 表示部 (連結台タイプ)
APPROVED 6/Feb/2020 HMAKI	外寸図
SCALE 1/10 MASS 32 10% 質量はケーブル・オプションを含まず。 MASS DOES NOT INCLUDE CABLE/OPTION.	NAME MONITOR UNIT (CONNECTION STAND TYPE)
DWG.No. C4493-004-B	OUTLINE DRAWING
REF.No. 26-009-130G-1	

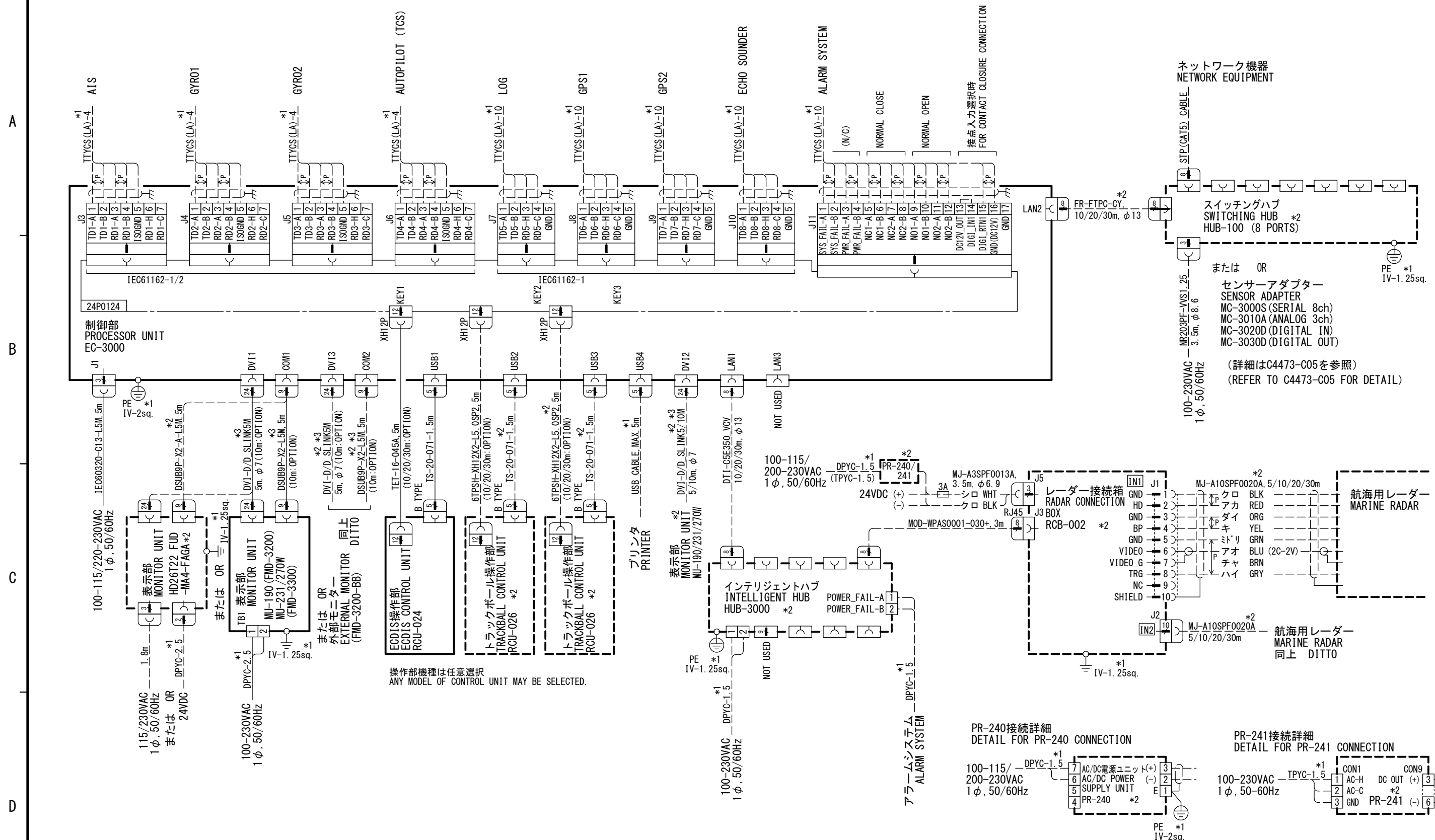

DRAWN 1/Nov/2021 T. YAMASAKI	TITLE FMD-3200 (-BB) /3300
CHECKED 1/Nov/2021 H. MAKI	名称 電子海図情報表示装置
APPROVED 2/Nov/2021 H.MAKI	相互結線図
SCALE MASS kg	NAME ECDIS
DWG. No. C4473-C06- A	REF. No. 24-014-6001-4
INTERCONNECTION DIAGRAM	

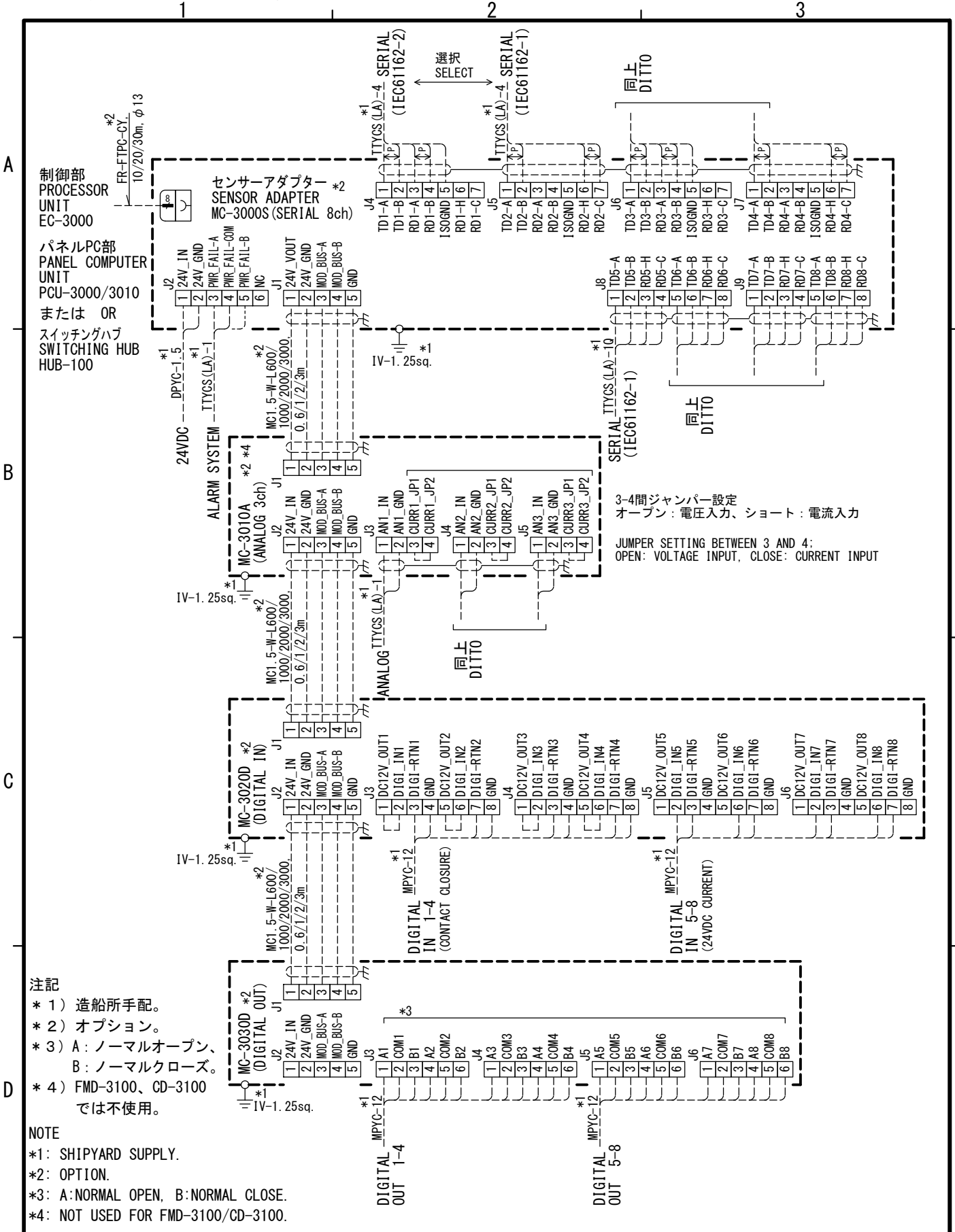

DRAWN 1/Nov/2021 T. YAMASAKI	CHECKED 1/Nov/2021 H. MAKI	APPROVED 5/Nov/2021 H. MAKI	SCALE MASS kg	DWG. No. C4473-C05- A	REF. No. 24-014-6003-2	TITLE MC-3000S/3010A/3020D/3030D	名称 センサーアダプター	相互結線図	NAME SENSOR ADAPTER
						INTERCONNECTION DIAGRAM			

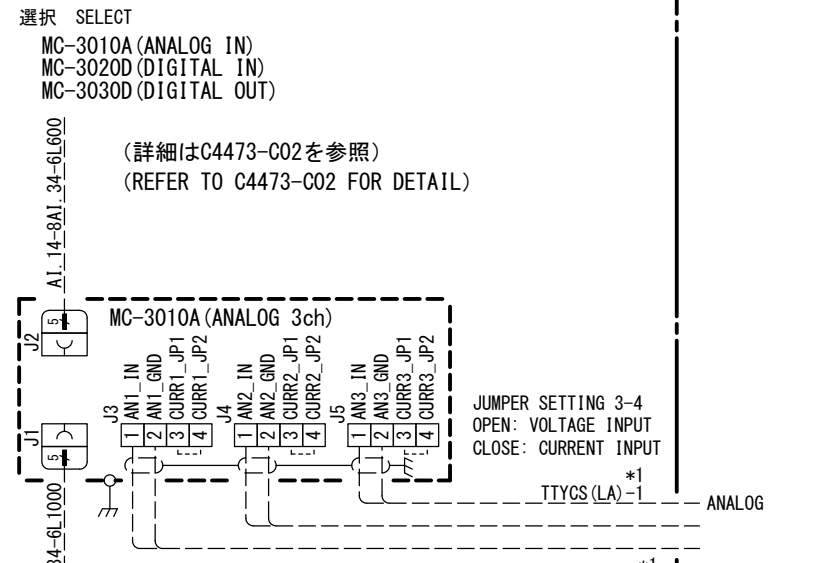
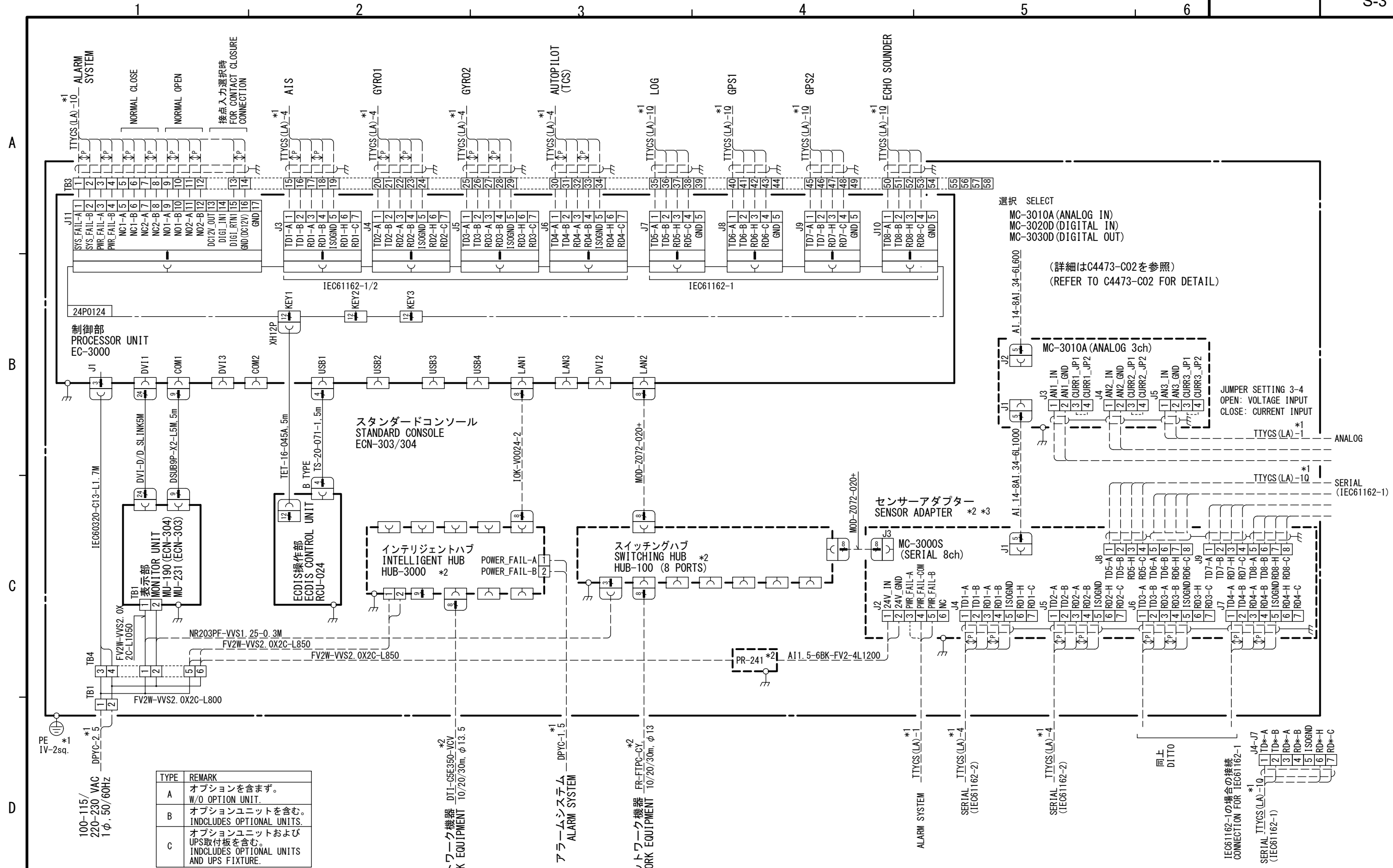

TYPE	REMARK
A	オプションを含まず。 W/O OPTION UNIT.
B	オプションユニットを含む。 INCLUDES OPTIONAL UNITS.
C	オプションユニットおよび UPS取付板を含む。 INCLUDES OPTIONAL UNITS AND UPS FIXTURE.

- 注記
- * 1) 造船所手配。
 - * 2) オプション。
 - * 3) センサーアダプターはMC-3000Sを含む3台までコンソール内に収納可。
- NOTE
- *1: SHIPYARD SUPPLY.
 - *2: OPTION.
 - *3: A CONSOLE CAN INCLUDE THREE UNITS (MC-3000S INCLUDED) AMONG SENSOR ADAPTERS.

DRAWN 10/Feb/2021 T. YAMASAKI	TITLE ECN-303/304-A/B/C
CHECKED 10/Feb/2021 H. MAKI	名称 スタンダードコンソール
APPROVED 6/Apr/2021 H. MAKI	FMD-3200/3300
SCALE MASS kg	NAME STANDARD CONSOLE
DWG. No. C4473-C03- F	REF. No. 24-014-6301-3
INTERCONNECTION DIAGRAM	