

# USER MANUAL

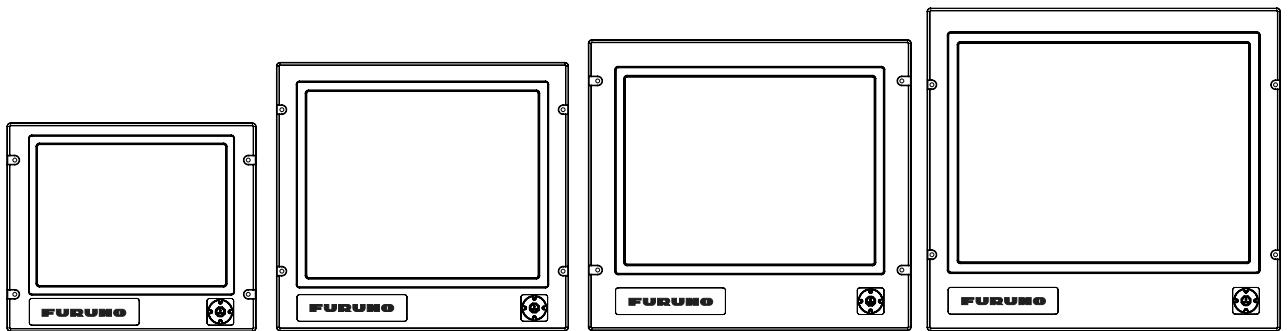

## Series 1 - Maritime Multi Display Furuno Models

JH 15T17 FUD-xxx-AOAA  
JH 19T14 FUD-xxx-AOAA  
JH 20T17 FUD-xxx-AOAA  
JH 23T12 FUD-xxx-AOAA

### User Manual FUD Series 1

Updated: 05 Feb 2010 | Doc Id: INB100036-3 (Rev 3)

For models:  
-AA1-AOAA, -DA1-AOAA

Created: 363  
Approved: 7235

Copyright © 2010 Hatteland Display AS  
Aamsosen, N-5578 Nedre Vats, Norway

Information in this manual is copyrighted to the respective owners. All rights are reserved by Hatteland Display AS. This information may not, in whole or in part, be copied, photocopied, reproduced, translated or reduced to any electronic medium or machine-readable form without the prior written consent of Hatteland Display AS.

The products described, or referenced, herein are copyrighted to the respective owners. The products may not be copied or duplicated in any way. This documentation contains proprietary information that is not to be disclosed to persons outside the user's company without prior written consent of Hatteland Display AS.

The copyright notice appearing above is included to provide statutory protection in the event of unauthorized or unintentional public disclosure.

**All other product names or trademarks are properties of their respective owners !**

WARNING: This is a class A product. In a domestic environment this product may cause radio interference in which case the user may be required to take adequate measures.

# Contents

<b>Contents</b> .....	<b>3</b>
Contents of package .....	6
<b>General</b> .....	<b>7</b>
Introduction to Furuno (FUD) display units .....	8
About this manual .....	9
About Hatteland Display .....	9
hatteland-display.com .....	9
Contact Information .....	9
Maritime Multi Display (MMD) - Introduction .....	10
Basic Construction .....	11
Product Labeling (examples) .....	12
<i>Labels and Locations</i> .....	12
<i>Typenumber Structure</i> .....	12
<i>Warranty Label</i> .....	13
<i>Quality Control (QC) Label</i> .....	13
<i>Front Logo Label</i> .....	13
<i>Radar Indication Label</i> .....	13
<b>Installation</b> .....	<b>15</b>
Installation and mounting .....	16
Ergonomics .....	17
Cables .....	18
<i>Cable Entries &amp; Connectors (Marked area) - Illustration only</i> .....	18
<i>Configuring DC power input housing connector</i> .....	18
HATTELAND® Multifunction Cables .....	18
Rotary Bracket / Mounting Bracket Assembly or Disassembly .....	19
Physical Connections - MMD / xxD based units .....	20
<b>Operation</b> .....	<b>23</b>
User Controls .....	24
Status LED Overview .....	26
OSD Menu Overview .....	27
OSD Menu Quick Start .....	27
OSD Functions Map .....	28











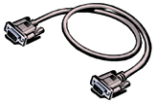

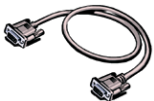

# Contents

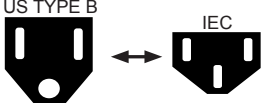
<b>Specifications .....</b>	<b>47</b>
Specifications - JH 15T17 FUD-xAx-AOAA .....	48
Specifications - JH 19T14 FUD-xAx-AOAA .....	49
Specifications - JH 20T17 FUD-xAx-AOAA .....	50
Specifications - JH 23T12 FUD-xAx-AOAA .....	51
<b>Technical Drawings .....</b>	<b>53</b>
Technical Drawings - JH 15T17 FUD-xAx-AOAA.....	54
Technical Drawings - JH 19T14 FUD-xAx-AOAA.....	55
Technical Drawings - JH 20T17 FUD-xAx-AOAA.....	56
Technical Drawings - JH 23T12 FUD-xAx-AOAA.....	57
<b>Technical Drawings - Accessories.....</b>	<b>59</b>
15" Sun Visor .....	60
19" Sun Visor .....	61
20" Sun Visor .....	62
23" Sun Visor .....	63
15" Rotary Bracket.....	64
17" > 23" Rotary Bracket.....	65
15" Bracket.....	66
17" > 20" Bracket .....	67
19" EN60945 Bracket.....	68
23" Bracket.....	69
23" EN60945 Bracket.....	70
15" TFT to 19" RACK Adapter.....	71
15" TFT to 17" CRT Adapter .....	72
19" TFT to 21" CRT Adapter .....	73
VESA Bracket - 15" .....	74
VESA Bracket - 19" .....	75
VESA Bracket - 20" .....	76
VESA Bracket - 23" .....	77
Water Cover - 15" .....	78
Water Cover - 19" (HW01) .....	79
Water Cover - 20" .....	80
Water Cover - 23" .....	81

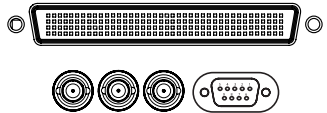
# Contents

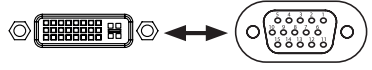
<b>Appendixes</b> .....	<b>83</b>
Pin Assignments - Common Connectors .....	84
Pin Assignments - Multifunction Cable Outputs .....	85
Basic Trouble-shooting .....	86
Declaration of Conformity .....	87
Return Of Goods Information .....	88
Terms .....	89
Pixel Defect Policy .....	91
Notes.....	92
Revision History .....	93

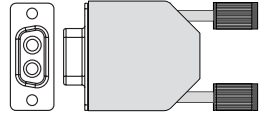
# Contents of package

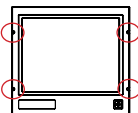
Item	Description	Illustration
 HA-SDM-2M	1 pcs of Standard DVI Signal Cable. DVI-D 24P Male to DVI-D 24P Male Dual Link - Length 2.0m	
 HA-VGA-2M-32	1 pcs of Standard VGA Signal Cable. DSUB 15P Male to DSUB 15P Male - Length 2.0m	
 FS-CABLE EU	1 pcs of power cable European Type F "Schuko" to IEC. Length 1.8m  <i>Note: Included in package for models with AC input.</i>	EUR TYPE F 
 80099	1 pcs of power cable US Type B plug to IEC. Length 1.8m  <i>Note: Included in package for models with AC input.</i>	US TYPE B 
 VSD100692-4	1 pcs of Standard 160p HATTELAND® Multifunction Cable #1 - Length: 30cm Connectors from the 160pin (male) are: - 3 x BNC Video IN (female) - 1 x 9p D-SUB (female) RS-232 COM I/O  <i>Note: This cable is only included with a product WITHOUT factory mounted touchscreen.</i>	
 DVI-4	1 pcs of DVI-I > RGB/VGA adapter DVI-I 29P Male to DSUB 15P Female	
 FCE17-E2W2SS-2NO & L17DPPK09JSU (cover)	1 pcs of DC Power Input housing with internal cable screw terminal.  <i>Note: Included in package for models with DC input.</i>	
 INB100036-3	1 pcs of printed User Manual.	
 1P06025 (screw) & 16M06012150 (washer)	4 pcs of M6X25 pan screws. Suitable for securing the display unit into a console cut-out. See illustration to the right.  <b>DO NOT USE THESE TO MOUNT BRACKETS ONTO THE UNIT.</b> Use the provided and dedicated screws for accessories (see next table below)	

## Package may also include:

Item	Description	Illustration
	4 pcs of M6X12 Unbraco bolts. These are included with mounting bracket, if ordered (review technical drawings chapter).  <b>Should only be used to secure the bracket onto display.</b> If you prefer your own bolts, make sure they do not exceed 12mm in length. Use any longer is not possible due to mechanical limits.	



# General

# Differences FUD vs MMD units

## Introduction to Furuno (FUD) display units

This manual (INB100036-3) apply for FUD units which is heavily based on Hatteland Display's standard user manual (INB100036-1) for Maritime Multi Display (MMD) units. It means that references to "MMD" also applies to FUD units in general form-fit and function terminology throughout this manual.

Technical drawings (AC only) and specifications (AC & DC) fully reflect the actual FUD units, however we see no need to illustrate the DC connector in technical drawings as it is almost not visible and have no physical impact during installment into consoles or during general installation.

## Visual differences FUD vs MMD

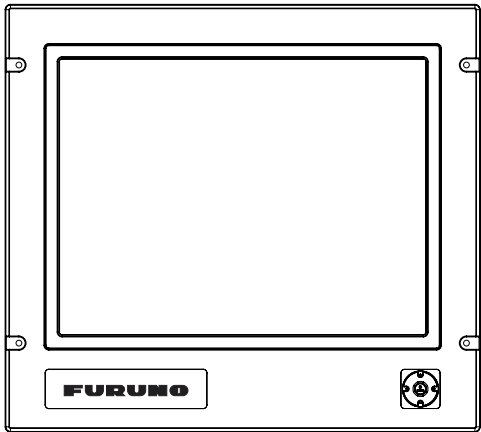
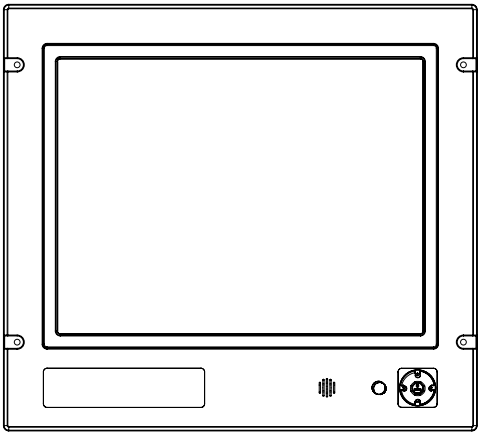
FUD	MMD
	
<ul style="list-style-type: none"><li>- FUD units have own logo on front.</li><li>- Only Keypad control is available.</li><li>- Brightness can not be controlled via keypad.</li><li>- Certain models are marked with Radar Label (4x1 cm)</li></ul>	<ul style="list-style-type: none"><li>- MMD units have no logo on front.</li><li>- Keypad Only / Keypad+Buzzer+Potmeter control is available.</li><li>- Brightness can be controlled via keypad or potmeter.</li></ul>

## Operational differences FUD vs MMD

FUD units feature their own customized ECOM On Screen Display (OSD) Firmware with the following exceptions different from the regular MMD OSD Firmware:

- 1: If Furuno Radar is connected to DVI input, the RS232 and user brightness control (via keypad) is disabled. The backlight brightness is instead controlled by the Radar Unit.
- 2: If Furuno Radar is connected to VGA/RGB input, the user brightness control (via keypad) is disabled. Backlight brightness is controlled by the RS232 interface via the "BRT" command.

**Note: The OSD chapter in this manual may reference to functions not available for FUD units due to the differences listed above.**

## Statement FUD vs MMD

Please note that all Testing and Type Approvals noted for MMD units are also valid for FUD units. The CE Declaration issued (mentions JH MMD) in this manual is also valid for JH FUD.



## About this manual

The manual contains electrical, mechanical and input/output signal specifications. All specifications in this manual, due to manufacturing, new revisions and approvals, are subject to change without notice. However, the last update and revision of this manual are shown both on the frontpage and also in the "Revision History" chapter. Please use that as a reference.

Furthermore, for third party datasheet and user manuals, please see dedicated interactive DVD (where included) delivered with the product or contact our sales/technical/helpdesk personnel for support.

## About Hatteland Display

Hatteland Display is the leading technology provider of maritime display and computer products. We deliver high quality, unique and customized solutions to the international maritime market.

The company represents innovation and quality to the system integrators world wide. Effective quality assurance and investment in sophisticated in-house manufacturing methods and facilities enable us to deliver type approved and Mil tested high quality products. Our customer oriented approach, technical knowledge and dedication to R&D, makes us a trusted and preferred supplier of approved solutions, which are backed up by a strong service network.

## hatteland-display.com

You will find our website full of useful information to help you make an informed choice as to the right product for your needs. You will find detailed product descriptions and specifications for the entire range on offer be it Series 1, Series 2, Computers & Panel Computers, Military solutions as well as the range of supporting accessories. The site carries a wealth of information regarding our product testing and approvals in addition to company contact information for our various offices around the world, the global service centers and the technical help desk, all ensuring the best possible support wherever you, or your vessel, may be in the world.

## Contact Information

<p><b>Head office, Vats / Norway:</b> Hatteland Display AS Åmsosen N-5578 Nedre Vats, Norway</p> <p>Tel: +47 5276 3700 Fax: +47 5276 5444</p> <p>info@hatteland-display.com</p>	<p><b>Sales office, Frankfurt / Germany:</b> Hatteland Display GmbH Werner Heisenberg Strasse 12, D-63263 Neu-Isenburg, Germany</p> <p>Tel: +49 6102 370 954 Fax: +49 6102 370 968</p>
<p><b>Sales office, Oslo / Norway:</b> Solbråveien 20-22 N-1383 Asker Norway</p> <p>Tel: +47 5276 3700 Fax: +47 6678 6001</p>	<p><b>Sales office, Aix-en-Provence / France:</b> Hatteland Display SAS 31 Parc du Golf, 350, Avenue JRGG de la Lauzière - CS 90519 13593 Aix-en-Provence Cedex 3, France</p> <p>Tel: +33 (0)4 42 16 35 15 Fax: +33 (0)4 42 16 35 09</p>
<p><b>Sales office, San Diego / USA:</b> Hatteland Display Inc. 11440 W. Bernardo Court, Suite 300 San Diego, CA 92127, USA</p> <p>Tel: +1 858 753 1959 Fax: +1 858 430 2461</p>	

For an up-2-date list, please visit [www.hatteland-display.com/locations](http://www.hatteland-display.com/locations)

# Displays Series 1

## Maritime Multi Display (MMD) - Introduction

With our dedication to innovation, we took our de facto industry standard Series 1 displays and set about improving them. The result is the Series 1 redesign, a new generation of innovative, rugged marine displays designed for any navigation and automation application, including ECDIS.

Although the new Series 1 offers a clear improvement on performance, functionality and value, we have ensured that it adheres to the Hatteland Display ethos of Form, Fit, Function, so you can harness the many innovative features, without making changes to your existing solutions.

Series 1 displays feature 0-100% dimming, and can provide unmatched sun and night vision. All sizes can benefit from Hatteland Display's sophisticated Optical Bonding, which eliminates condensation and dust, and reduces reflection by over 90%.

Together with advanced anti-glare coatings, bonding enables you to see your display in bright sunlight without the need for extensive backlighting, which can cause overheating and a shorter product life cycle.

Series 1 introduces a number of signal input/output options, which can be increased by using the HATTELAND® Multifunction Cable. Further customized cables are available to ensure that you can interface everything you need to with the greatest of ease.

All Series 1 models are built to last and designed to be reliable in harsh environments, while providing the performance and flexibility you expect. They are perfectly suited to use aboard a wide range of vessels including commercial ships, workboats, coast guard boats and navy ships.

## A new generation of innovative, rugged marine displays.....

- TYPE APPROVED
- ECDIS COMPLIANT
- NEW CONNECTIVITY
- NEW FUNCTIONALITY
- FORM, FIT AND FUNCTION
- SUPERIOS BONDING TECHNOLOGY

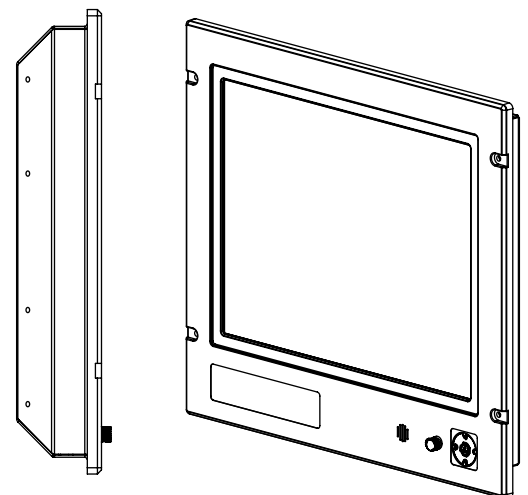
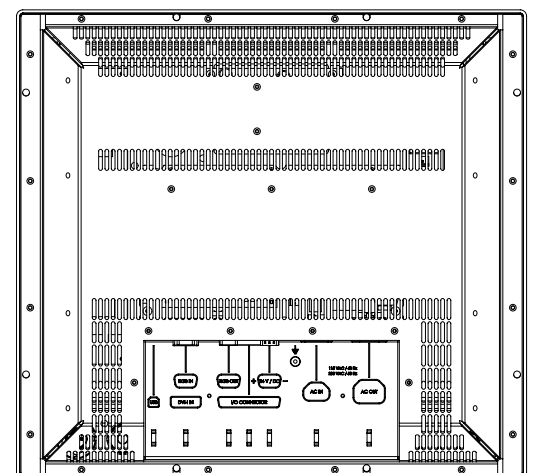
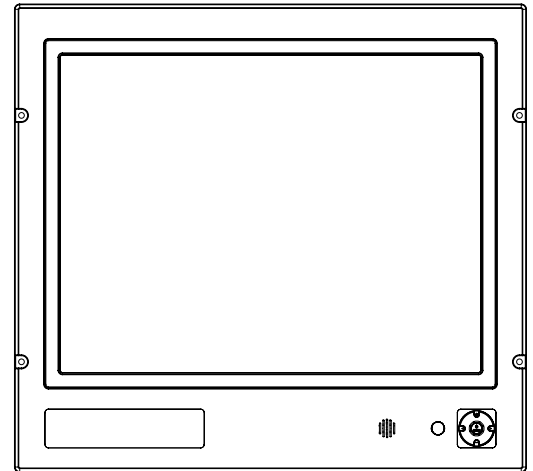

# Basic Construction

## Basic Construction - Series 1

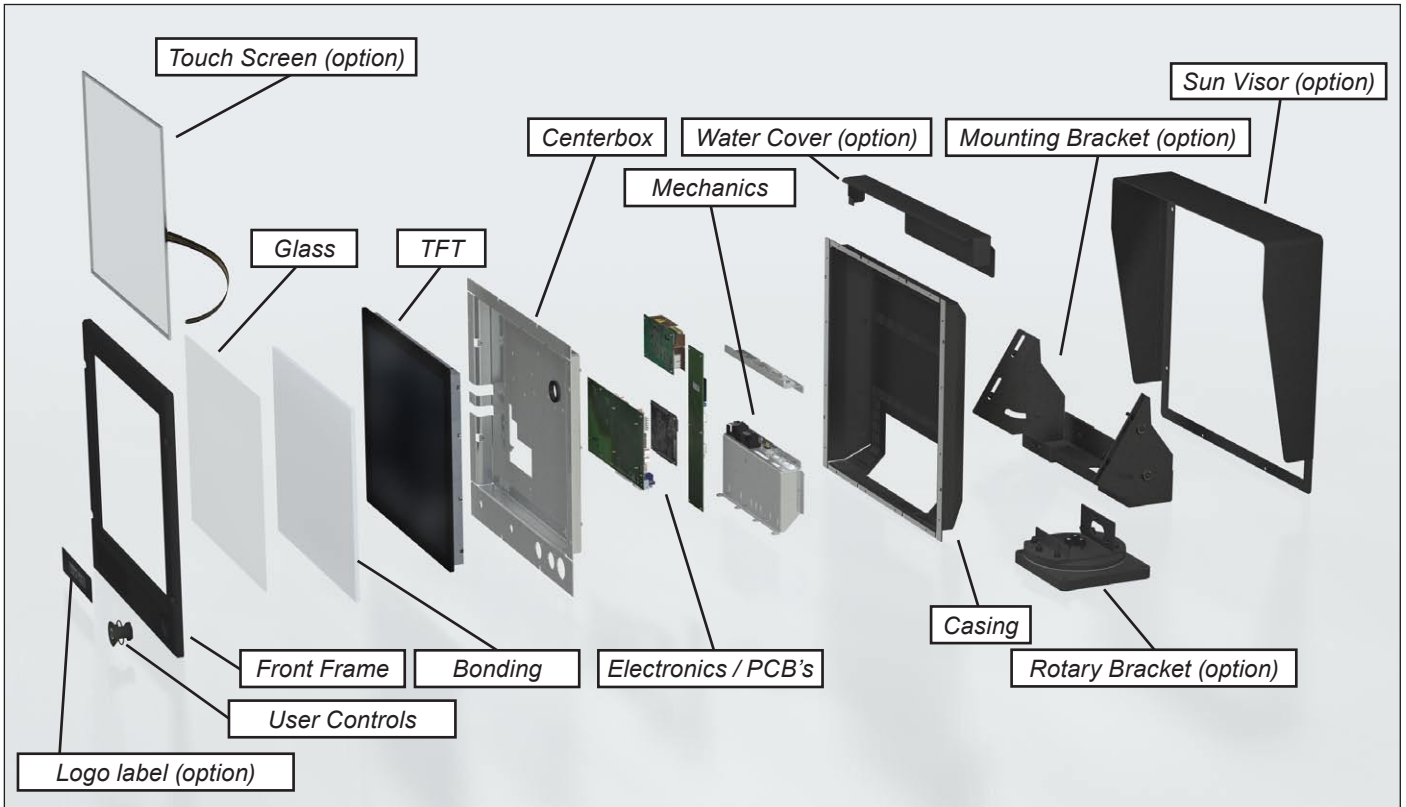

Example with mounting bracket



Example with sun visor, mounting bracket and rotary bracket



# Product Labeling (examples)

## Labels and Locations

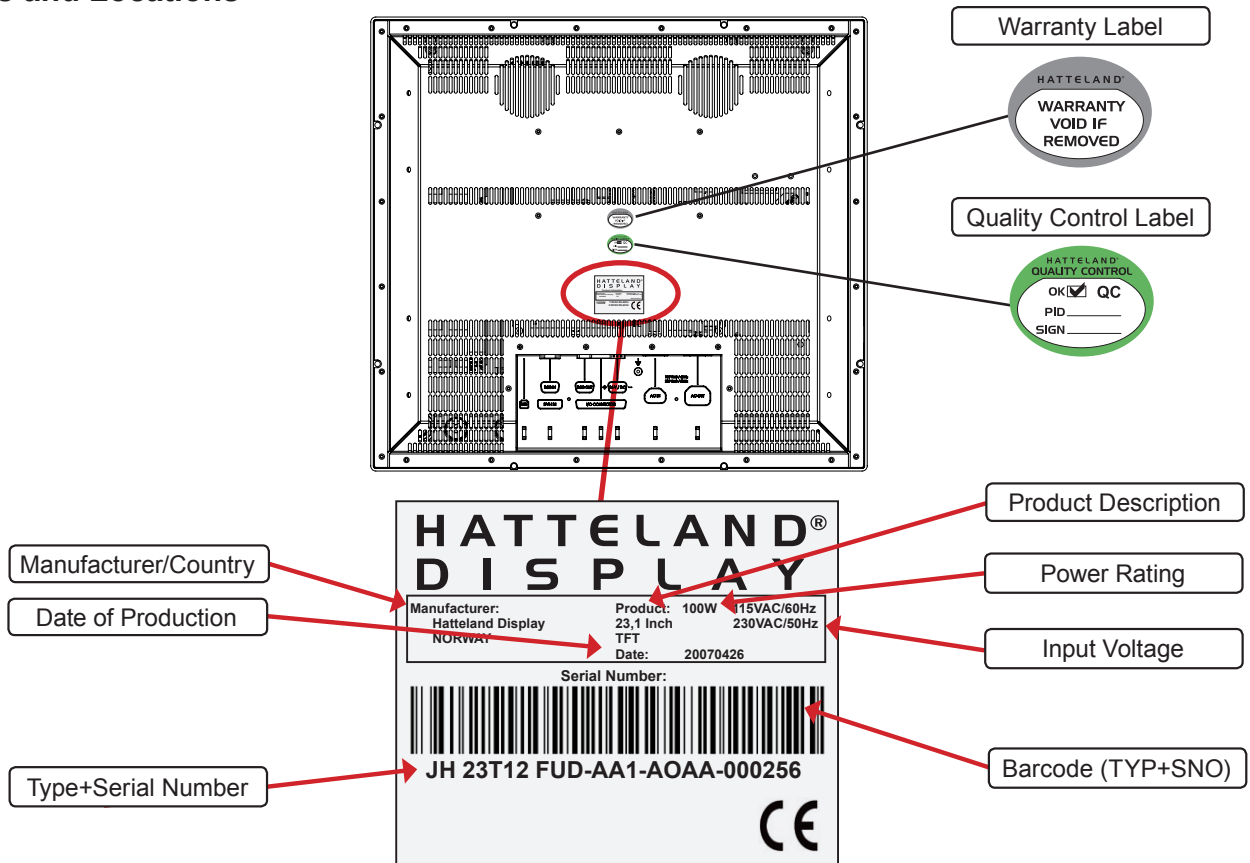

## Typenumber Structure

The structure shown below derive from the standard Hatteland Display MMD units, but FUD units uses the same logic in their type numbers.

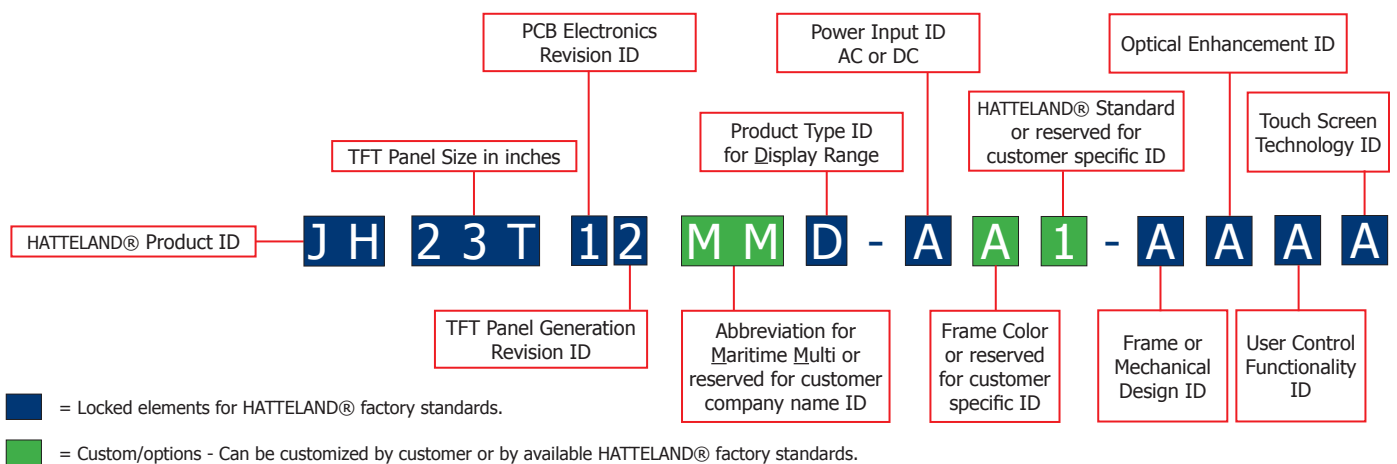

## Product Labels (Example)

### Warranty Label

If you are to perform service on a unit still under warranty, any warranty will be void if this label shows signs of removal attempts (re-gluing) or removed completely. This label is located on the back of the product and covers a key screw. This is to aid service departments to determine if there has been any unauthorized service on a unit still under warranty.

### Quality Control (QC) Label

This label indicates that the unit is produced, tested and packed according to manufacturer's QA specifications. It will include a Personal ID and signature by the person responsible for approving the unit in production, test and warehouse departments.

### Front Logo Label

The Hatteland Display MMD front frame design offers an area for customized logo label. The products are factory delivered with the FURUNO logo in white as shown.

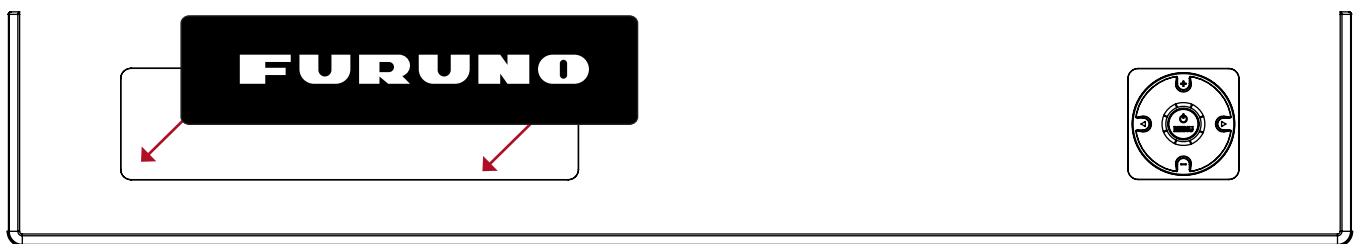

WxH = 181.66 x 44.16mm / 7.15" x 1.74". R4.10 - 4 places in each corner. Depth of area is 0.5mm.

### Radar Indication Label

Units designated for Radar Application use ONLY are marked on the front frame with a 4cm x 1cm label:



Full typenumber with the label part number and rev.x (where x indicates revision)

This page left intentionally blank



# Installation

# General Installation Recommendations

## Installation and mounting

1. Most of our products are intended for various methods of installation or mounting (panel mounting, bracket mounting, ceiling/wall mounting etc.); for details, please see the relevant mechanical drawings.
2. Adequate ventilation is a necessary prerequisite for the life of the product. The air inlet and outlet openings must definitely be kept clear; coverings which restrict ventilation are not permissible.
3. Generally, do not install the unit in a horizontal position (laying down), as this will cause heat to build up inside the unit which will damage the LCD Panel. To prevent this problem we recommend installing the unit in a vertical position ( $\pm 30$  degrees) to improve the airflow through the unit.
4. To further improve the cooling of the unit we recommend installing Cooling Fans underneath blowing upwards into the unit air inlet. This may be required in high temperature applications and also when there is reason to expect temperature problems due to non-optimal way of mounting.
5. Exposure to extreme direct sunlight can cause a considerable increase in the temperature of the unit, and might under certain circumstances lead to overtemperature. This point should already be taken into consideration when the bridge equipment is being planned (sun shades, distance from the windows, ventilation, etc.)
6. Space necessary for ventilation, for cable inlets, for the operating procedures and for maintenance, must be provided.
7. If the push buttons of the product are not illuminated, an external, dimmable illumination (IEC 60945 Ed. 4, 4.2.2.3, e.g. Goose neck light) is required for navigational use. The illumination shall be dazzle-free and adjustable to extinction.
8. Information about necessary pull-relievers for cables is indicated in the Physical Connection section of this manual. Attention must be paid to this information so that cable breaks will not occur, e.g. during service work.
9. Do not paint the product. The surface treatment influences on the excess heat transfer. Painting, labels or other surface treatments that differ from the factory default, might cause overheating.

## General mounting instructions

- The useful life of the components of all Electronics Units generally decreases with increasing ambient temperature; it is therefore advisable to install such units in air-conditioned rooms. If there are no such facilities these rooms must at least be dry, adequately ventilated and kept at a suitable temperature in order to prevent the formation of condensation inside the display unit.
- With most Electronic Units, cooling takes place via the surface of the casing. The cooling must not be impaired by partial covering of the unit or by installation of the unit in a confined cabinet.
- In the area of the wheel house, the distance of each electronics unit from the magnetic standard compass or the magnetic steering compass must not be less than the permitted magnetic protection distance. This distance is measured from the centre of the magnetic system of the compass to the nearest point on the corresponding unit concerned.
- Units which are to be used on the bridge wing must be installed inside the "wing control console" protected against the weather. In order to avoid misting of the viewing screen, a 25 ... 50 W console-heating (power depending on the volume) is recommended.
- When selecting the site of a display unit, the maximum cable lengths have to be considered.



## General Installation Recommendations

- When a product is being installed, the surface base or bulkhead must be checked to ensure that it is flat in order to avoid twisting of the unit when the fixing screws are tightened, because such twisting would impair mechanical functions. Any unevenness should be compensated for by means of spacing-washers.
- The grounding screws of the units must be connected to the body of the ship (ground); the wire used should have a cross sectional area of at least 6 mm<sup>2</sup>.
- Transportation damage, even if apparently insignificant at first glance, must immediately be examined and be reported to the freight carrier. The moment of setting-to-work of the equipment is too late, not only for reporting the damage but also for the supply of replacements.

### Brightness knob precaution

Applies for models with potmeter knob. Please be aware of the risk of breaking or bending the brightness knob. The brightness knob should be free of any obstruction.

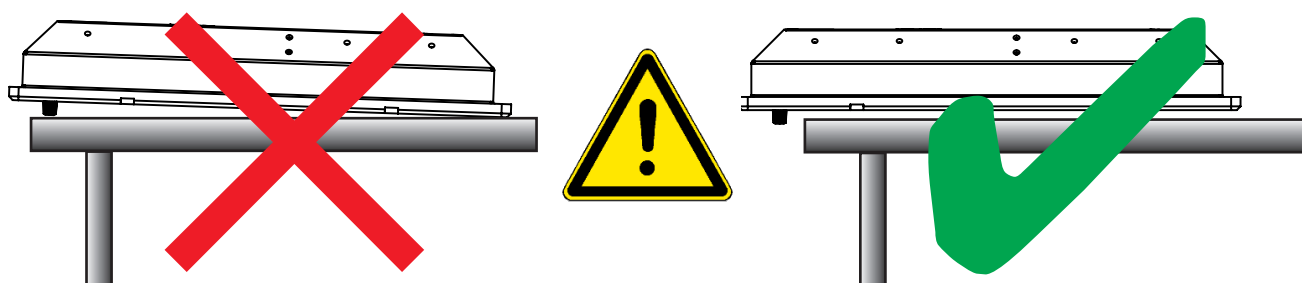

### Ergonomics

1. Adjust the unit height so that the top of the screen is at or below eye level. Your eyes should look slightly downwards when viewing the middle of the screen.
2. Adjust screen inclination to remain gaze angle to the centre of the screen approximately perpendicular to the line of gaze.
3. When products are to be operated both from a sitting position and from a standing position, a screen inclination of about 30° to 40° (from a vertical plane) has turned out to be favourable.
4. The brightness of displays is limited. Sunlight passing directly through the bridge windows - or its reflection - which falls upon the screen workplaces must be reduced by suitable means (negatively inclined window surfaces, benetian blinds, distance from the windows, dark colouring of the deckhead). However, Series 1 can be offered with optical enhanced technology to reduce reflections and are viewable in direct sun light, but as a general rule the units at the bridge wing area is recommended to be installed or mounted by suitable alignment or bulkhead / deckhead mounting in such a way that reflections of light from the front pane of the display are not directed into the observer's viewing direction.
5. The use of ordinary commercial filter plates or filter films is not permitted for items of equipment that require approval (by optical effects, "aids" of that kind can suppress small radar targets, for example).
6. For ECDIS applications, the minimum recommended viewing distance are as follows:  
(IEC62288, Part 7.5 Screen resolution)

17 inch = 908mm	19 inch = 1011mm	20 inch = 878mm	23 inch = 1011mm	27 inch = 1000mm	
-----------------	------------------	-----------------	------------------	------------------	--

# General Installation Recommendations

## Cables

Use only high quality shielded signal cables and the provided HATTELAND® Multifunction Cable.

### Cable Entries & Connectors (Marked area) - Illustration only

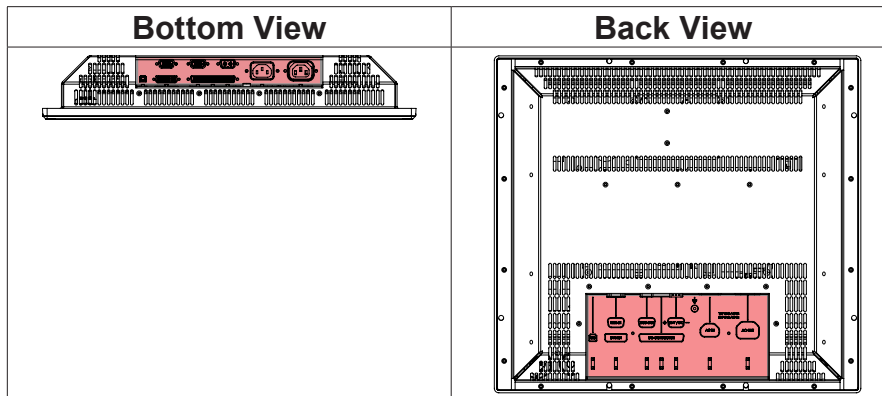

The cable should generally be kept as short as possible to provide a high quality input/output. The maximum signal cable length will depend on the signal resolution and frequency, but also on the quality of the signal output from the computer/radar. Recommended refresh rate is 60Hz. Cables up to 10 meters generally provides good picture quality even with a 1600x1200 (UXGA) 60Hz signal. In most cases (especially with lower resolutions) even longer cables will provide a satisfactory result. This should however be tested in advance before making the decision on how far the unit can be placed from the signal source.

### Configuring DC power input housing connector

For installations that require DC power input, use the provided 2-pin DC Power Input housing with internal cable screw terminal.

- 1: Open the housing
- 2: Unmount the fasteners. (FIG 1)
- 3: Mount power cables to screw terminal (FIG 2)
- 4: Secure the cable tightly with fasteners (FIG 3, FIG 1)
- 5: Close the housing

Note: Please check polarity before connecting any cables to the screw terminal.

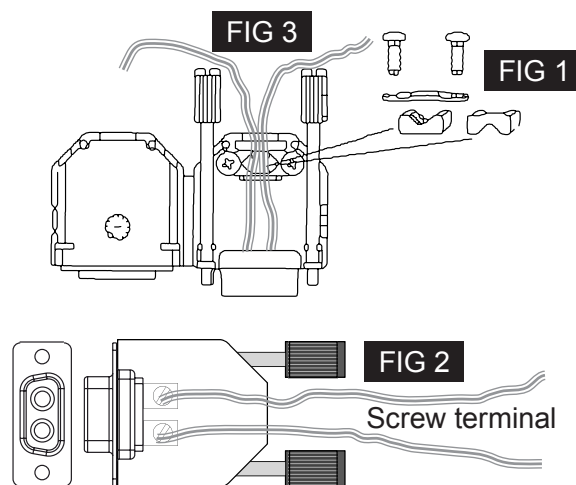

## HATTELAND® Multifunction Cables

This custom HATTELAND® Multifunction Cable with its 160 pins offers a wide range of additional signal types to be used together with the display units. Please refer to the Contents of Package in this manual to determine which cable and connector functionality you received.



The cable could also be customized upon customer request for length or to support other signal types and connectors. Using any other cable/housing design to connect to the display units could result in severe damage to components! Please use it only with HATTELAND® display products as specified in this manual.

# General Installation Recommendations

## Rotary Bracket / Mounting Bracket Assembly or Disassembly

Use the provided bolts included in the package to assemble the brackets. Follow the steps below. You must provide your own bolts to secure it to a table / desktop. Recommended size is: M10 and minimum 30mm in length.

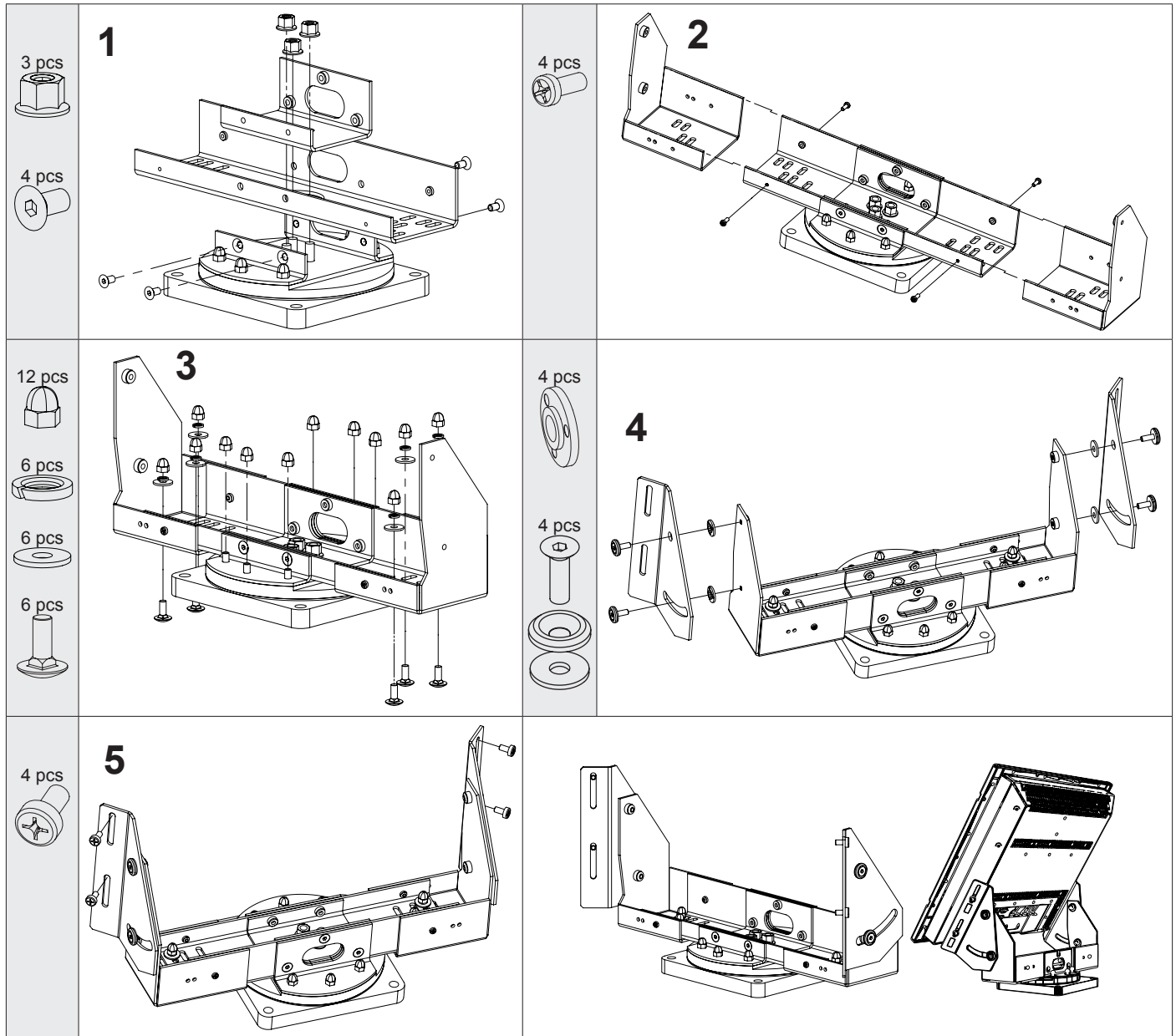

## Mounting Bracket

Note that the length of bolts should not exceed 12mm (ref: #1 and 5). Using any longer is not possible due to mechanical design inside which are designed to protect the electronics. Review also technical drawings chapter in the manual for measurements and dimensions of brackets.

# 1: Mount bolts on each side.

Make adjustments before securing the bolts.

# 2: Adjust the tilting angle and secure the bolts.

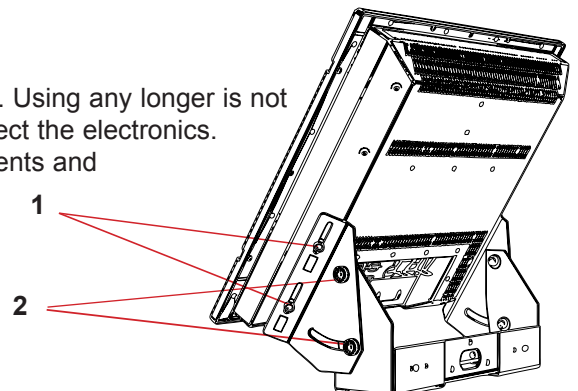

# Physical Connections - MMD / xxD based units

## Connection area of unit (illustration)

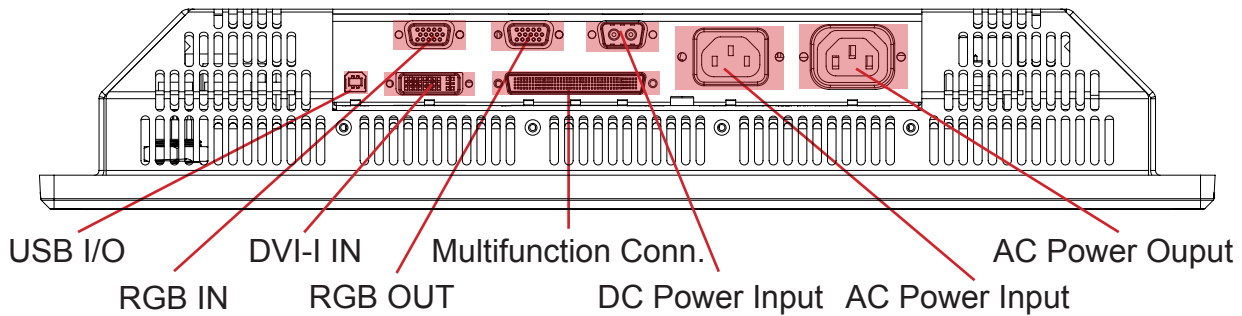

### Cable Tension

To reduce tension of the cables you connect, secure them with a cable tie to the base mounted clamp or to the chassis hinges.

For certain units a base mounted clamp is available (FIG 1). For other models a hinge in the chassis is available (FIG 2).

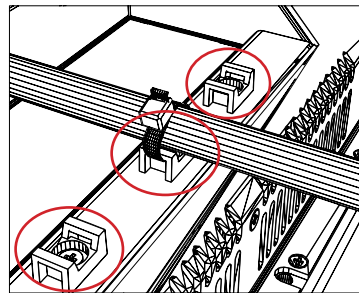

FIG 1

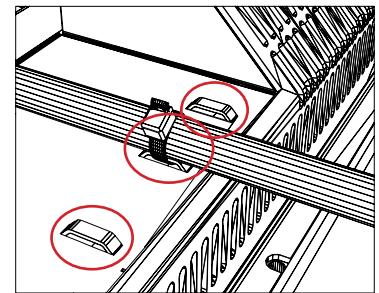
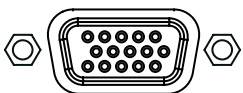

FIG 2



### USB I/O:

This USB TYPE B connector is reserved for customized solutions. One customized example could be to connect it to a computer USB connection via a TYPE B-A cable and then accessing it via a front USB TYPE A connector on the front frame bezel to utilize a mouse or other control device.



### RGB IN:

Connect the VGA cable to the D-SUB 15P Connector (female). Secure the VGA cable to the hex spacers provided on the unit and make sure you do not bend any of the pins inside the connector when connecting. Connect the other end of the cable to the VGA connector on your equipment and secure it.

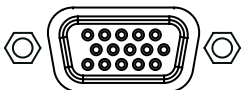

### RGB OUT:

RGB OUT enables a direct clone of the incoming VGA (RGB1) signal. Connect the cable to the D-SUB 15P Connector (female) and secure it to the hex spacers provided on the unit. Connect the other end to your equipment and secure it. Note that DVI inputs is NOT cloned, even though if the DVI-I connector has been configured with the DVI-I > RGB adapter to use a RGB signal as input.

## Physical Connections - MMD / xxD based units

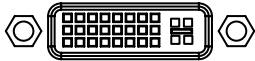

### DVI-I IN:

Connect your DVI cable to the DVI-I 29P Connector (female). The DVI-I connector can function as regular RGB IN by using a DVI-I > RGB/VGA adapter. Secure the DVI cable to the hex spacers provided on the unit and make sure you do not bend any of the pins inside the connector. Connect the other end of the cable to the DVI connector on your equipment and secure it.

### Important note for DVI signal detection:

*Please note that for the operating system to detect DVI signals correctly, the DVI cable MUST be connected physically to the unit during boot up otherwise you may experience a black image. Furthermore certain graphics drivers may need to refresh their device list (often done manually by user - detect devices), while in some cases the Plug-n-Play will automatically detect the DVI signal correctly. Please consult your local technician if you have this behaviour of detection problems when using DVI. In all cases the problem can be solved in the operating system, and this is not a malfunction in the graphic controller for HATTELAND® units.*

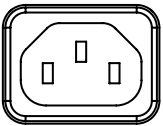

### POWER INPUT: (For units supporting AC input)

The internal AC power module supports both 115VAC/60Hz and 230VAC/50Hz power input. Please check specifications for your unit.

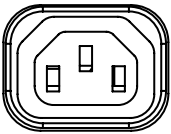

### POWER OUTPUT: (For models supporting AC output)

The internal AC power module supports both 115VAC/60Hz and 230VAC/50Hz power input. Please check specifications for your unit.

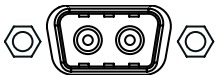

### POWER INPUT: (For models supporting DC input)

Connect your DC power cable to the 2P Amphenol FCC17 D-SUB Connector (male). Secure the cable to the hex spacers provided on the unit, and secure the other end to your power supply. The internal DC power module supports 24VDC. Please check specifications for your unit.

## Physical Connections - MMD / xxD based units

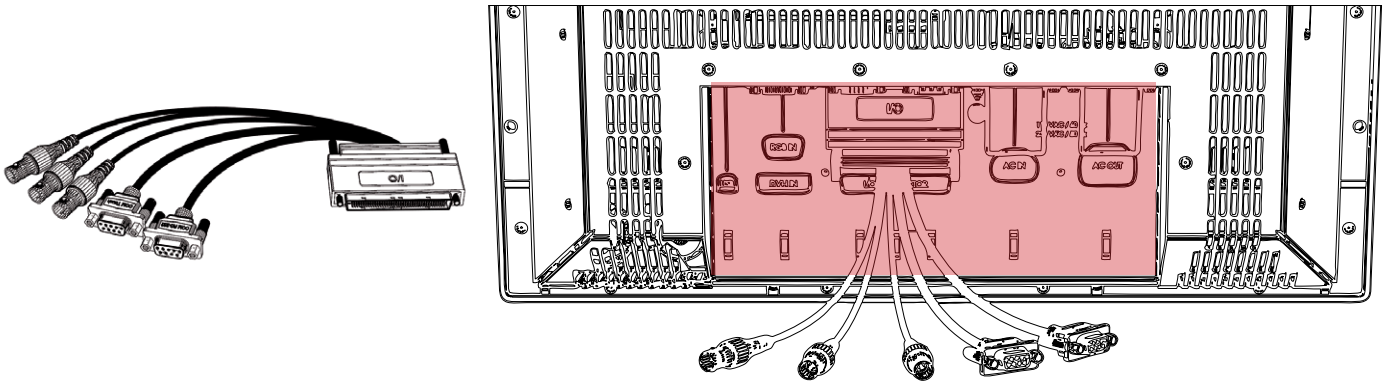

Note: Other HATTELAND® Multifunction Cables may include other connections based on a customized solution.

### ◉ HATTELAND® MULTIFUNCTION CONNECTOR :

Mount the 160 PIN cable connector (male) to the 160 PIN connector (female) on the back of the unit as indicated above. Make sure you fasten it firmly with the provided housing screws to the hex spacers provided on the unit. By using this cable you can access more signal types than already present by the factory mounted connectors. By factory standards two cables are available. One for non-touch screen based unit and one for units with factory mounted touch screen. From this cable you can now have access to the following signal types described below.



### 3 x COMPOSITE IN/VIDEO IN (Cable #1/#2):

Connect your BNC cable connector (male) to any of the 3 available BNC Connectors (female) on the unit. This will allow 3 different video signals from i.e. cameras & dvd players to be visible on screen either as full screen video or Picture-In-Picture/Picture-By-Picture. To activate any of these functionalities, the unit must be configured via the OSD menu (see own chapter). PAL / NTSC / SECAM VIDEO signal formats supported.

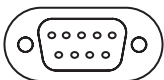

### COM RS-232 (Cable #1/#2):

This 9P COM connector provides additional functionality for the unit. The Serial Remote Control features a RS232 interface for controlling internal MMD parameters like brightness. You can access most of the parameters available in the OSD menu and with special commands control the unit externally. A in-depth manual (when made available) can be located at the website: [www.hatteland-display.com](http://www.hatteland-display.com) (support/accessories) for the SCOM interface. This COM can also be used to upgrade the firmware for the graphic controller inside the unit which is available on request and through service channels (for qualified personnell).

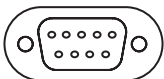

### COM TOUCH (Cable #2):

This 9P COM connector provides touch screen communication for units that have been equipped with a factory mounted touch screen. It should be connected to a computer with touch screen drivers installed. See the touch screen chapter in this manual for more information.



# Operation

## USER CONTROLS OVERVIEW

The tactile only keypad controls with 5 push buttons and the Status LED Ring. The keypad provide the user to access the configuration menu and use the Direct Access / Hotkey functionality. The LED ring will provide feedback for various status or modes that the unit can or currently operates in.

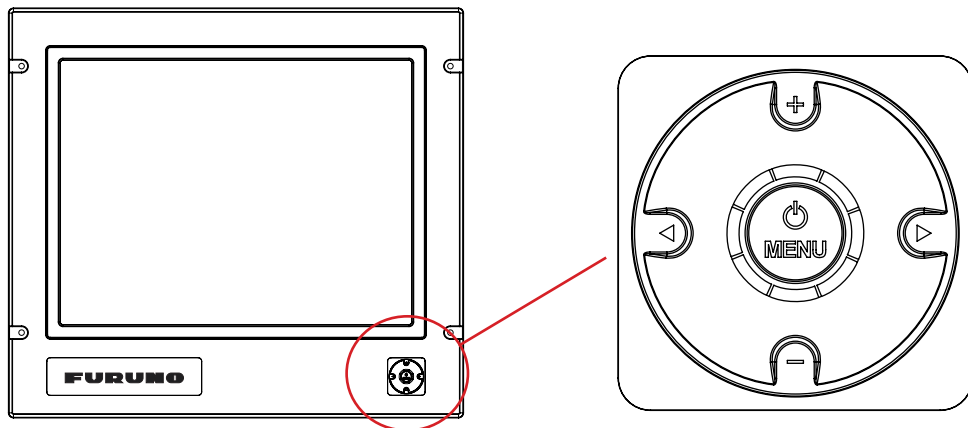

### **Power ON:**

To turn the unit on, push the navigator MENU button inwards and release it instantly. The unit will start searching for signal sources. A green led will move around the led ring to indicate the search procedure. Please consult the STATUS LED overview later in this chapter for the various LED patterns that can occur.

### **Power OFF:**

To turn the unit off, push the navigator MENU button inwards and hold it down for 6 seconds. After the first 3 seconds the menu will appear. 3 seconds later the unit is turned off and all LED indicators will turn red. You can now release the power button. Please consult the STATUS LED overview later in this chapter for various LED patterns that can occur.



## KEYPAD FUNCTIONALITY

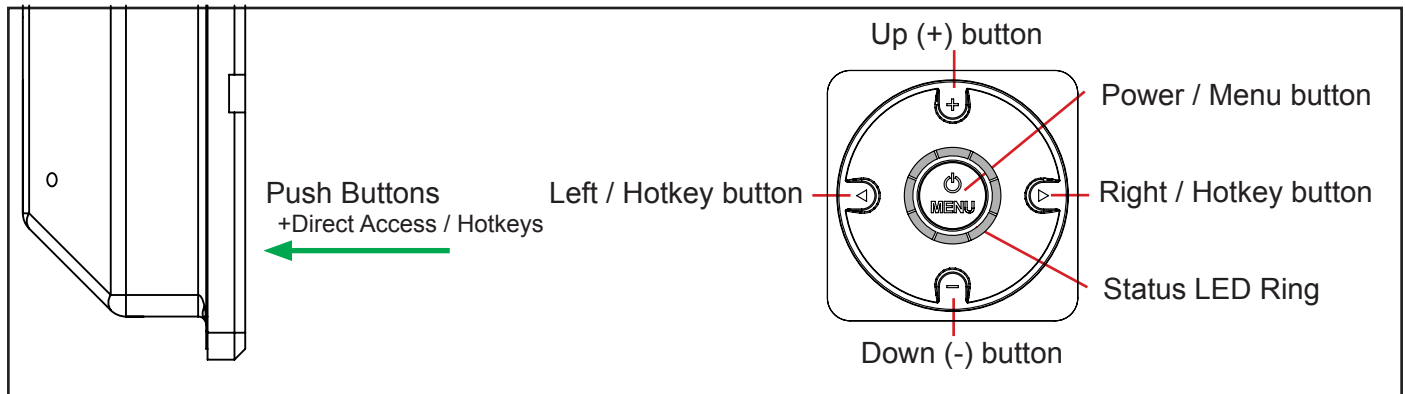

### **MENU** function as:

Power On/Off & On Screen Display (OSD) menu access.

### **LEFT (◀)** function as:

Direct Access / Hotkey, exit the current function and navigate to the previous OSD menu.

### **RIGHT (▶)** function as:

Direct Access / Hotkey, enter sub-menu & execute/set selected function.

### **UP (+)** function as:

Increase brightness, adjust positive values, visual movement, OSD menu navigating upwards & confirm.

### **DOWN (-)** function as:

Decrease brightness, adjust negative values, visual movement, OSD menu navigating downwards & confirm.

## **DIRECT ACCESS / HOTKEY FUNCTION**

You can access a number of functions from within the OSD Menu which is normally only accessible by browsing through the OSD Menu and locate the function manually. The Direct Access function are assigned to the Left and Right buttons to function as hotkeys. Note that some functions are dual (increase/decrease) or just single (swap/next). Those with single functionality both the left and right keypad button will perform the same action.

To configure the Direct Access / Hotkeys functionality, just press one of the buttons inwards and release it instantly, detection time is immediate.

Available assigned functions for Direct Access are: **Brightness, PIP Size, Main Source, Second Source, Alpha Blend, Video Scaling, Swap Source, Test Pattern and No Function.**

Please review the "OSD Menu Function" chapter for configuring the direct access / hotkeys functionality.

# Status LED Overview

## Status LED Overview



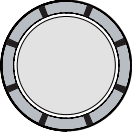
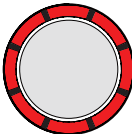
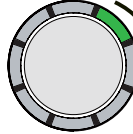
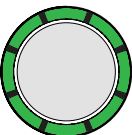
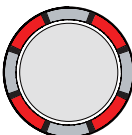
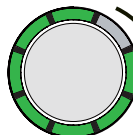
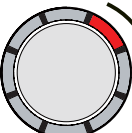

The unit features a multi purpose indicator LED status ring which through different patterns and realtime activity gives back the status of the signal detected, power on/off, calibration, menu activity and more. The LEDs are multicolored which either illuminate green or red, based on the activity.

<p><b>OFF (No power connected)</b></p>  <p>8 LED OFF</p>	<p><b>OFF (Standby, power detected)</b></p>  <p>8 RED LED STATIC ON</p>	<p><b>ON (Signal Search)</b></p>  <p>1 GREEN LED MOVEMENT looping.</p>
<p><b>ON (Signal OK)</b></p>  <p>8 GREEN LED STATIC ON</p>	<p><b>ON (No Signal)</b></p>  <p>4 RED LED STATIC ON</p>	<p><b>ON (Menu Delay)</b></p>  <p>7 GREEN LED STATIC + 1 LED OFF MOVEMENT doing 1 loop.</p>
<p><b>OFF (Shutdown)</b></p>  <p>1 RED LED MOVES for 3 sec. After additional 3 secs, all leds turns RED.</p>		

# OSD Menu Overview

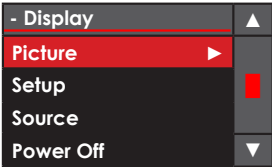
## OSD Menu Quick Start

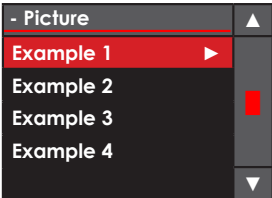
To understand the workflow of the OSD menu, follow these steps for a quick start. The table shows the various OSD overlays you might encounter while navigating, adjusting parameters or when text messages are displayed. The OSD menu always remembers its last position which is indicated by the red bar.

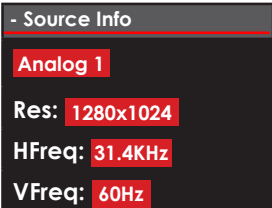
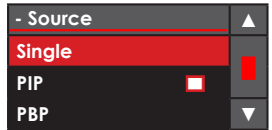
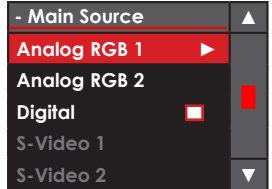
<p><b>1</b> Press the <b>physical MENU</b> button for 3 sec. The OSD menu will pop-up as an overlay over the existing image on screen. All the available functions you can adjust or control are now available as an easy understandable menu structure.</p> <p>The current choice will be marked with a red selection bar.</p> <p>You can now navigate up or down in the menu with the <b>physical up/down buttons</b> (indicated as +/- symbols on the user control).</p> <p>To select a function, press the <b>physical right arrow button</b>. You will now enter the sub menu of that function or execute it (if its available).</p>	  <p>The arrow indicates either a sub-menu or function is available. It is now required to press the <b>physical right button</b> to access the function / sub-menu.</p>
<p><b>2</b> The top header will indicate what the contents of the menu group consists of. In this example “-Picture”. The previous menu will not be visible. To navigate to the previous menu, press the <b>physical left arrow button</b>.</p> <p>The first choice in the sub-menu will be marked with a red bar. Navigate with the <b>physical up/down buttons</b> (indicated as +/- symbols on the user control).</p> <p>To select a function, press the <b>physical right arrow button</b>. You will now enter the sub menu for that function or execute it (if its available).</p>	
<p><b>3</b> <i>Example of the adjust parameter OSD overlay:</i></p> <p>Use the <b>physical up/down</b> (indicated as +/- on the user control) buttons to adjust the value. All changes happen in real-time while adjusting these parameters and the number in the middle of the OSD will also change real-time.</p> <p>After you are satisfied with the value, press the <b>physical left arrow button</b> to store the parameter. Depending on the function, you will now either enter the previous menu or exit from it completely.</p>	
<p><b>4</b> <i>Example of the text information OSD overlay:</i></p> <p>After you have read the information displayed, press the <b>physical left arrow buttons</b> to enter the previous menu and exit the information displayed.</p>	
<p><b>5</b> <i>Example of the indicator symbol (white box):</i></p> <p>When you have several parameters to choose from, the white box will indicate which parameter are now currently activated. In this example; The “PIP” function is configured to be active.</p> <p>To active any other function, just navigate to it press the <b>physical right arrow button</b>. The box will appear next to the text indicating it is activated.</p>	
<p><b>6</b> <i>Example of a non active function (greyed out text):</i></p> <p>Please note that certain functions may be disabled by factory default or by means of customized menu structure/product setup. These functions cannot be accessed or executed when they appear in gray text color. In this illustration the S-Video inputs are disabled in the OSD menu as the product does not have any physical S-Video input connectors.</p>	
<p><b>7</b> To exit from the OSD menu at any menu level or in any other OSD overlay, just press the <b>physical MENU button</b>. The menu will disappear, and the last setting adjusted will be stored. Alternatively you can wait for the OSD to reach time-out and exit automatically without user interaction. Parameters will be saved.</p>	

# OSD Menu Overview

## OSD Functions Map

The OSD menu consists of main function groups with sub menu groups. On the following pages a complete map of the available functions is shown. The following section should be viewed in color. Please note that the red selection bar is not indicated in any of the following illustrations.



**Please note: Factory default illustrations only! Available functions, icons and text may deviate slightly from actual OSD menu on your product due to different OSD software configurations and customized solutions.**

## Legend Map

The OSD menu have functions that are specific for RGB mode, DVI mode or when using the “Full” or “Simplified” menu structure. This means that not all functions shown in the menu structure is available in all modes. To easier identify which function is available in what mode, the illustrations in this section is marked with different colors (legends). These colors are not visible in the real OSD menu.

	= Always available for all modes.
	= Always available for all modes.
	= Only available in “Full” menu mode.
	= Only available in RGB mode, i.e. VGA/RGB signal input is shown full screen.
	= Only available in “Full” and RGB modes.
	= Only available in DVI/RGB mode.
	= Only available in Comp/S-VHS mode, i.e. Video Signal is shown full screen.
	= Only available if Picture-In-Picture (PIP) or Picture-By-Picture (PBP) is on.

## Main Menu - Display

In this illustration the 3 main groups are shown.

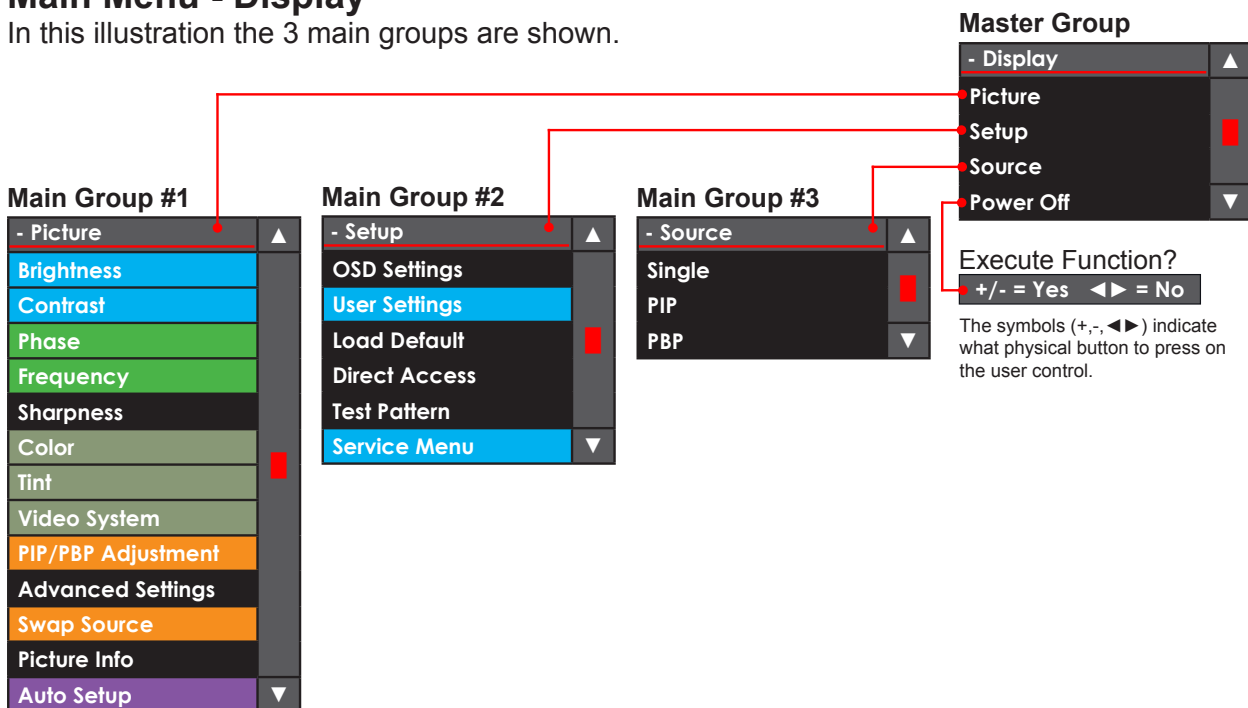

# OSD Menu Overview

## Main Group #1 - Picture

In this group (with its sub groups) the user can adjust parameters that directly impact the picture visually for all incoming signal sources. Some of these Sub Groups have more options, please review this map to quickly determine the location of your desired function/option. For detailed information, please review the "OSD Menu Functions" later in this section.



**Please note: Factory default illustrations only! Available functions, icons and text may deviate slightly from actual OSD menu on your product due to different OSD software configurations and customized solutions.**

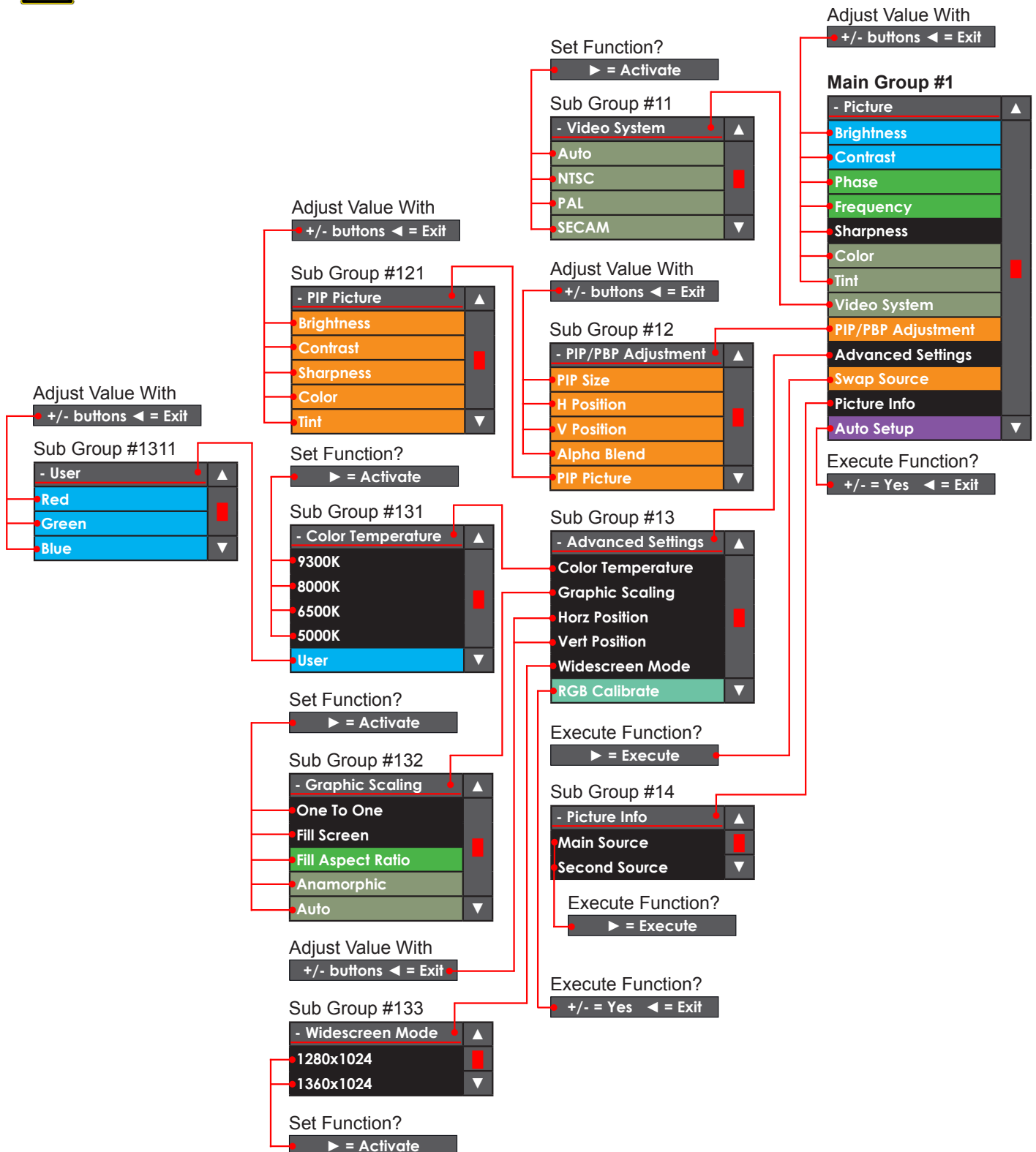

# OSD Menu Overview

## Main Group #2 - Setup

In this group (with its sub groups) the user can adjust parameters that directly impact settings for the video controller software, OSD settings and gain access to settings that are physically accessible for the user. None of these settings will impact on the picture visually for the incoming signal sources. Some of these Sub Groups have more options, please review this map to quickly determine the location of your desired function/option. For detailed information, please review the “OSD Menu Functions” later in this section.



**Please note: Factory default illustrations only! Available functions, icons and text may deviate slightly from actual OSD menu on your product due to different OSD software configurations and customized solutions.**

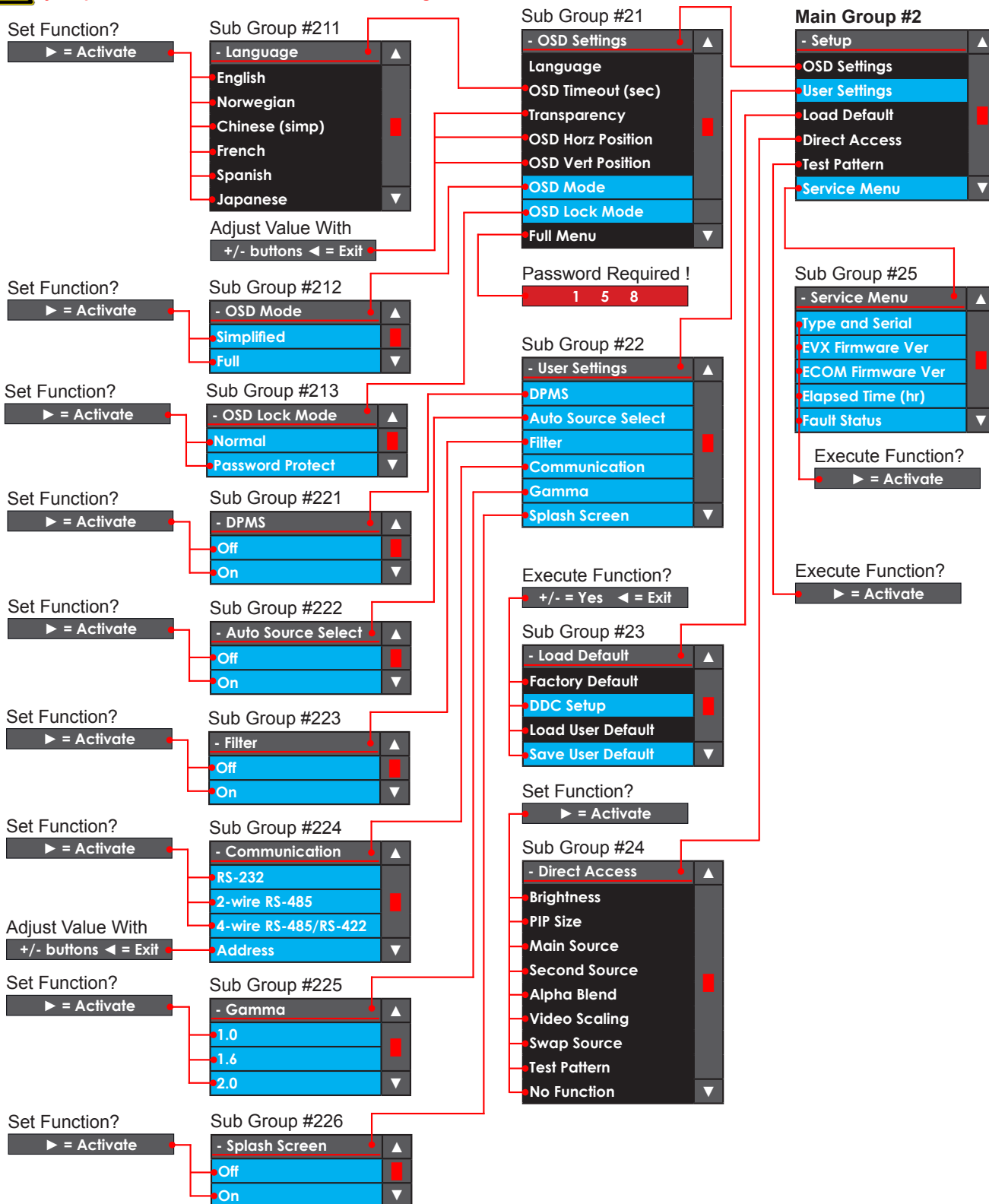

# OSD Menu Overview

## Main Group #3 - Source

In this group (with its sub groups) the user can change the signal input source and setup the Picture-In-Picture views or Picture-By-Picture views which both take advantage of the Maritime Multi Display functionality. Some of these Sub Groups have more options, please review this map to quickly determine the location of your desired function/option. For detailed information, please review the "OSD Menu Functions" later in this section.



**Please note: Factory default illustrations only! Available functions, icons and text may deviate slightly from actual OSD menu on your product due to different OSD software configurations and customized solutions.**

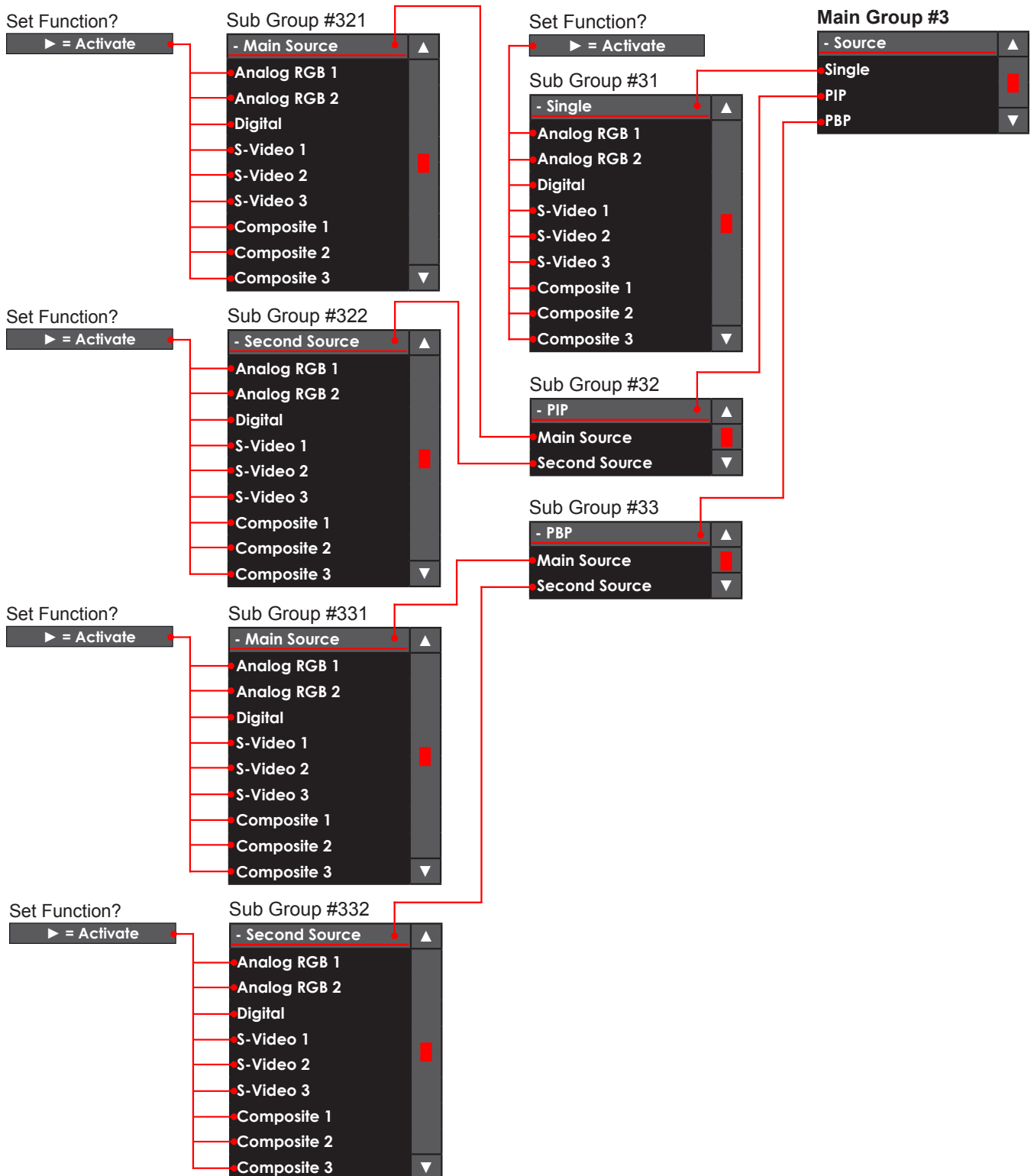

# OSD Menu Functions

## OSD Menu Functions

The following section covers all possible settings that the user can (in a certain mode) encounter or needs to adjust. The structure of these commands are identified as paths. Please review the “OSD Menu Overview Map” earlier in this manual to see the different paths if you have not already made yourselves familiar with the OSD Menu structure. Most functions are performed in real time so you do not have to exit the OSD menu to see the results.



**Please note: Available functions described may deviate slightly from actual OSD menu on your product. This is due to different OSD software configurations and customized solutions.**

### Display / Picture / Brightness

*Function only available in “Full” menu mode.*

Increase/decrease the overall brightness of the panel electronically by controlling the voltage level. This applies to the Main Source signal. Window overlays (PIP/PBP) and the OSD Menu overlay will be unaffected. This will be independent of the actual adjustment done by the front user controls like potmeters or buttons.

- Level adjusts from 0-100 steps. 50 is default.

### Display / Picture / Contrast

*Function only available in “Full” menu mode.*

Increase/decrease the overall contrast of the panel electronically by controlling the voltage level. This applies to the Main Source signal. Window overlays (PIP/PBP) and the OSD Menu overlay will be unaffected. This will be independent of the actual adjustment done by the front user controls like potmeters or buttons.

- Level adjusts from 0-100 steps. 50 is default.

### Display / Picture / Phase

*This function only apply for analog VGA/RGB signals.*

Fine tune the data sampling position of the signal (impacts on image quality). This function will remove small transparent defects in typical characters where a portion seems to be more faint than the nearby black pixels. The faint pixels are always visible as a line from top to bottom (vertically).

- Level adjusts from 0-100 steps. Default is based on signal source.

### Display / Picture / Frequency

*This function only apply for analog VGA/RGB signals.*

Adjust the horizontal frequency of the analog signal to improve visibility of the entire image. When it is adjusted, you will notice that the image will appear to be stretched and might in some situations start to flicker/scroll, at which point you must reverse the last adjustment to stop it from flickering/scrolling anymore. This function can be used for older signals that is not automatically detected by the internal display controller.

- Level adjusts from 0-200 steps. Default is based on signal source.

### Display / Picture / Sharpness

Increase/decrease the overall image sharpness. This affects the whole panel, and applies to all signal inputs and window overlays (PIP/PBP). Use it to increase the visual quality of signals from possible older equipment or electronically weak signals.

- Level adjusts from 0-15 steps. 7 is default.



## OSD Menu Functions

### Display / Picture / Color

*This function only apply for analog Composite/S-VHS video signals when set as Main Source.*

Increase/decrease the overall video color saturation/color amount. Can be used if the incoming signal from older equipment or bad cables appear to have a lack of strong colors. Note that this function can also make noisy color signals appear crisper/clearer if adjusted to grayscales. Recommended is to use factory setting which is set to a neutral and a normalized level and use high quality cables.

- Level adjusts from 0-100 steps. 50 is default.

### Display / Picture / Tint

*This function only apply for analog Composite/S-VHS NTSC video signals when set as Main Source.*

Increase/decrease the overall video tint. This will adjust all colors brighter or darker which makes the image more “washed out” or stronger in terms of color intensity. Can be used if the incoming signal from older equipment or bad cables appear to have a lack of strong colors. Recommended is to use factory setting which is set to a neutral and a normalized level.

- Level adjusts from 0-100 steps. 50 is default.

### Display / Picture / Video System / Auto - DEFAULT

*This function only apply for analog Composite/S-VHS video signals when set as Main Source.*

Force automatic detection of video system format (factory default). Does not auto detect SECAM!

- When selected, a box icon (  ) will indicate that the selected function has been activated.

### Display / Picture / Video System / NTSC

*This function only apply for analog Composite/S-VHS video signals when set as Main Source.*

Force the video system format to NTSC for all video inputs. If you feed the product with another video format expect flickering, missing colors or other visual deviations. If this happens either change to AUTO or change the video out settings on your external peripheral if possible.

- When selected, a box icon (  ) will indicate that the selected function has been activated.

### Display / Picture / Video System / PAL

*This function only apply for analog Composite/S-VHS video signals when set as Main Source.*

Force the video system format to PAL for all video inputs. If you feed the product with another video format expect flickering, missing colors or other visual deviations. If this happens either change to AUTO or change the video out settings on your external peripheral if possible.

- When selected, a box icon (  ) will indicate that the selected function has been activated.

### Display / Picture / Video System / SECAM

*This function only apply for analog Composite/S-VHS video signals when set as Main Source.*

Force the video system format to SECAM for all video inputs. If you feed the product with another video format expect flickering, missing colors or other visual deviations. If this happens either change to AUTO or change the video out settings on your external peripheral if possible.

- When selected, a box icon (  ) will indicate that the selected function has been activated.

# OSD Menu Functions

## Display / Picture / PIP-PBP Adjustment / PIP Size

To enable this function, please see [ **Display / Source / xxx / xxx** ] later in this section of the manual. Increase/decrease the Picture-In-Picture and Picture-By-Picture window sizes. These functions will allow any of the signal inputs to be placed as a real time window overlay (or side by side if using PBP) on top of the current Main Source signal enabling the main feature of the Maritime Multi Display functionality.

- Max PIP H size = 656 pixel
- Max PIP V size = Max PIP H size x Panel V resolution / Panel H resolution
- Min PIP H size = 256 pixel
- Min PIP V size = Min PIP H size x Panel V resolution / Panel H resolution
- 40 pixel each step.

## Display / Picture / PIP-PBP Adjustment / H Position

To enable this function, please see [ **Display / Source / xxx / xxx** ] later in this section of the manual. Move the horizontal (left/right) position of the real time window overlay.

- Level adjusts from 0-100 steps. 0 is default.

## Display / Picture / PIP-PBP Adjustment / V Position

To enable this function, please see [ **Display / Source / xxx / xxx** ] later in this section of the manual. Move the vertical (up/down) position of the real time window overlay.

- Level adjusts from 0-100 steps. 0 is default.

## Display / Picture / PIP-PBP Adjustment / Alpha Blend

To enable this function, please see [ **Display / Source / xxx / xxx** ] later in this section of the manual. Increase/decrease the alpha blend also known as transparency of the real time window overlay. It means that the Main Source signal will show through the PIP image. It is used when important information in the Main Source signal behind the window overlay is necessary to be visible at all times.

- Level adjusts from 0-100 steps. 100 is default.

## Display / Picture / PIP-PBP Adjustment / PIP Picture / Brightness

To enable this function, please see [ **Display / Source / xxx / xxx** ] later in this section of the manual. Increase/decrease the overall brightness of the window overlay. This will not change the brightness of the Main Source signal behind the window overlay. It can be used for situations where the incoming video signal from CCTV or other video sources appear to dark in comparison to the Main Source signal.

- Level adjusts from 0-100 steps. 50 is default.

## Display / Picture / PIP-PBP Adjustment / PIP Picture / Contrast

To enable this function, please see [ **Display / Source / xxx / xxx** ] later in this section of the manual. Increase/decrease the overall contrast of the window overlay. This will not change the contrast of the Main Source signal behind the window overlay. It can be used for situations where the incoming video signal from CCTV or other video sources appear to “washed out” in comparison to the Main Source signal.

- Level adjusts from 0-100 steps. 50 is default.

## OSD Menu Functions

### Display / Picture / PIP-PBP Adjustment / PIP Picture / Sharpness

To enable this function, please see [ Display / Source / xxx / xxx ] later in this section of the manual.

Increase/decrease the overall image sharpness. This will not change the sharpness of the Main Source signal behind the window overlay. Use it to increase the visual quality of signals from possible older equipment or electronically weak signals.

- Level adjusts from 0-15 steps. 7 is default.

### Display / Picture / PIP-PBP Adjustment / PIP Picture / Color

This function only apply for analog VIDEO IN signals.

To enable this function, please see [ Display / Source / xxx / xxx ] later in this section of the manual.

Increase/decrease the overall video color saturation/color amount. Can be used if the incoming signal from older equipment or bad cables appear to have a lack of strong colors. This will not change the color saturation/intensity of the Main Source signal behind the window overlay. Note that this function can also make noisy color signals appear crisper/clearer if adjusted to greyscale.

- Level adjusts from 0-100 steps. 50 is default.

### Display / Picture / PIP-PBP Adjustment / PIP Picture / Tint

This function only apply for analog VIDEO IN signals.

To enable this function, please see [ Display / Source / xxx / xxx ] later in this section of the manual.

Increase/decrease the overall video tint (applies only for NTSC video signals.). This will adjust all colors brighter or darker which makes the image more “washed out” or stronger in terms of color intensity. Can be used if the incoming signal from older equipment or bad cables appear to have a lack of strong colors. This will not change the color tint of the Main Source signal behind the window overlay.

- Level adjusts from 0-100 steps. 50 is default.

### Display / Picture / Advanced Settings / Color Temperature / xx00K

Adjust the color temperature measured in Kelvin degrees. You can choose between 9300K, 8000K, 6500K and 5000K. This applies to the Main Source signal. Window overlays (PIP/PBP) and the OSD Menu overlay will be unaffected. Lower values make the image appear warmer, while higher values will make it appear cooler. Default is set to 9300K. The Kelvin color temperature scale (approximate and symbolic):

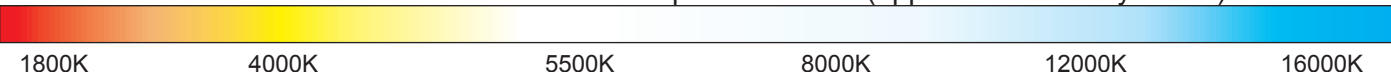

- When selected, a box icon ( ■ ) will indicate that the selected function has been activated.

### Display / Picture / Advanced Settings / Color Temperature / User / RGB

Function only available in “Full” menu mode.

Adjust the color temperature manually. You can adjust the R(red), G(green) and B(blue) levels. This applies to Main Source signal. The window overlays (PIP/PBP) and the OSD Menu overlay will be unaffected.

- Press the right (▶) button to activate each R,G,B level and adjust them separately.

## OSD Menu Functions

### Display / Picture / Advanced Settings / Graphic Scaling / One to One

Function only available in "Full" menu mode & when analog DVI/VGA/RGB signal are set as Main Source. Set the image scaling to 1:1. This means that the incoming signal is shown as is (with correct aspect ratio) and without any scaling to fit the display area. If the image appears to have black bars at top/bottom or/and left/right area, the external signal source is the cause of this. It does not support the signal in respect of what the native TFTs panel resolution requires.

- When selected, a box icon ( ■ ) will indicate that the selected function has been activated.

### Display / Picture / Advanced Settings / Graphic Scaling / Fill Screen

Function only available in "Full" menu mode & when analog DVI/VGA/RGB signal are set as Main Source. Set the image scaling to fit the entire native TFT panel resolution. This means that the incoming signal is shown (without correct aspect ratio) and with scaling to fit the entire display area. The result is that the image will appear stretched. The external signal source is the cause of this. It does not support the signal in respect of what the native TFTs panel resolution requires.

- When selected, a box icon ( ■ ) will indicate that the selected function has been activated.

### Display / Picture / Advanced Settings / Graphic Scaling / Fill Aspect Ratio - DEFAULT

Function only available in "Full" menu mode & when analog DVI/VGA/RGB signal are set as Main Source. Set the image scaling to fit the entire native TFTs panel resolution based on correct aspect ratio (factory default). This means that the incoming signal is scaled to best possible fit within the entire display area. The result is that black bars might be visible in top/bottom and/or left/right area. The external signal source is the cause of this. It does not support the signal in respect of what the native TFT panel resolution requires.

- When selected, a box icon ( ■ ) will indicate that the selected function has been activated.

### Display / Picture / Advanced Settings / Graphic Scaling / Anamorphic

Function only available in "Full" menu mode & when analog Comp/S-VHS signals are set as Main Source. Will scale the widescreen image to fit a 4:3 or 5:4 native TFTs panel resolution. Anamorphic widescreen is a video technique that utilizes rectangular (wide) pixels to store a widescreen picture into standard 4:3 format. The result is that black bars will be visible in top/bottom area. The external signal source is the cause of this. It does not support the signal in respect of what the native TFT panel resolution requires. If the TFT panel is not of a widescreen type, this option must be selected to prevent the widescreen signal for being scaled in height and appear very stretched.

- When selected, a box icon ( ■ ) will indicate that the selected function has been activated.

### Display / Picture / Advanced Settings / Graphic Scaling / Auto

Function only available in "Full" menu mode & when analog Comp/S-VHS signals are set as Main Source. The display controller will automatically try to identify the incoming signal and scale the image with respect of the aspect ratio and the TFTs native resolution to best possible fit the image on the entire display area. Since this is a automatic and electronically intelligent function it may not work correctly with all signal types. You may have to choose one of the other graphic scaling techniques above to get the correct/desired image appearance.

- When selected, a box icon ( ■ ) will indicate that the selected function has been activated.

## OSD Menu Functions

### Display / Picture / Advanced Settings / Horz Position

Move the horizontal (left/right) position of the entire display area. This applies to the Main Source signal. Please note that this function can move information in the image outside the visible display area, so use caution when modifying this parameter.

- Level adjusts from 0-100 steps. 50 is default.

### Display / Picture / Advanced Settings / Vert Position

Move the vertical (up/down) position of the entire display area. This applies to the Main Source signal. Please note that this function can move information in the image outside the visible display area, so use caution when modifying this parameter.

- Level adjusts from 0-100 steps. 50 is default.

### Display / Picture / Advanced Settings / Widescreen Mode

This will force the display controller to scale the image to match the incoming signal from typical radar systems with a custom resolution of 1360x1024. Since the display controller are unable to automatically detect the difference between this resolution and 1280x1024, the user have the option to manually set the display to the required resolution. Setting the resolution to 1280x1024 will only use the native TFTs panel resolution (for 19inch only). For other TFT sizes it will use the native TFT panel resolution instead (1:1).

- When selected, a box icon ( ■ ) will indicate that the selected function has been activated.

### Display / Picture / Advanced Settings / RGB Calibrate



**Warning! The displayed image MUST be a black/white image (color/gray scale image not usable). If not, the calibration will produce wrong color values!**

*Function only available in "Full" menu mode and when analog VGA/RGB signal are set as Main Source.* This function will automatically calibrate the R(red), G(green), B(blue) signal gain values, also known as the color intensity to a neutral and a normalized level. This function will also override any previous color adjustments done by user in the OSD menu. It will also override the Kelvin color temperature setting and affects the Main Source signal.

- Press the right (▶) button to activate. A confirmation requester will appear. Use +/- to confirm.

### Display / Picture / Swap Source

*This function will be available if PIP/PBP is on, please see [ Display / Source / xxx / xxx ].*

This function will swap the image in fullscreen and the window overlay. It will choose whatever signal inputs set in the [ Display / Source / xxx / xxx ] setting as Main Source and Second Source.

- Press the right (▶) button to activate in real-time. The OSD menu will still be visible.

### Display / Picture / Picture Info / Main Source

*Please note that a valid input signal must be present for this function to work.*

This function will show the picture information as detected by the display controller such as Physical Port Input Name, Current Signal Resolution, H-Freq. (horizontal frequency) and V-Freq. (vertical frequency). It will not perform any changes or adjustments to the display settings and signals.

- When selected, a box icon ( ■ ) will indicate that the selected function has been activated.

## OSD Menu Functions

### Display / Picture / Picture Info / Second Source

*Please note that a valid input signal must be present for this function to work.*

This function will show the picture information as detected by the display controller such as Physical Port Input Name, Current Signal Resolution, H-Freq. (horizontal frequency) and V-Freq. (vertical frequency). It will not perform any changes or adjustments to the display settings and signals.

- When selected, a box icon (  ) will indicate that the selected function has been activated.

### Display / Picture / Auto Setup

*Function only available when analog VGA/RGB signal are set as Main Source.*

This function will try to re-negotiate with the current signal input and its specifications like frequency etc. to perform an auto-adjusting on screen to correct aspect ratio, centered on screen, re-negotiate phase/frequency (for analog signals). All signal inputs and image adjustments will be reset. It will not reset any configuration done for the OSD Menu overlay and various other user settings. This function can be used in cases where you suspect a faulty or unsuitable configuration of the unit is present. It can also be used in trouble-shooting situations to determine that the display are not or are the reason for a faulty or undesirable operation. The problem may be from external equipment.

- Press the right (  ) button to activate. A confirmation requester will appear. Use +/- to confirm.

### Display / Setup / OSD Settings / Language

This function will choose the default language to use in all OSD menu/text/messages for the entire display controller software. Available languages may be: English (default), Norwegian, Chinese (simplified), French, Spanish and Japanese. Please note that the manufacturer's user manual is currently only in English.

- When selected, a box icon (  ) will indicate that the selected function has been activated.

### Display / Setup / OSD Settings / OSD Timeout (sec)

Increase/decrease the timeout period in seconds for the OSD Menu overlay to automatically disappear without the user having to manually exit from the OSD menu.

- Level adjusts from 5-30 seconds. 20 is default.

### Display / Setup / OSD Settings / Transparency

Increase/decrease the alpha blend also known as transparency of the OSD Menu overlay. It means that all signals inputs and PIP/PBP images show through the OSD Menu. It is used when important information on the display is necessary to be visible at all times. A black border around the OSD menu layout will always be black and is not affected by this adjustment.

- Level adjusts from 0-100 steps. 50 is default.

### Display / Setup / OSD Settings / OSD Horz Position

Move the horizontal (left/right) position of the OSD Menu overlay. The OSD Menu can only be moved within the max display area available.

- Level adjusts from 0-100 steps. 100 is default.

# OSD Menu Functions

## Display / Setup / OSD Settings / OSD Vert Position

Move the vertical (left/right) position of the OSD Menu overlay. The OSD Menu can only be moved within the max display area available.

- Level adjusts from 0-100 steps. 100 is default.

## Display / Setup / OSD Settings / Full Menu

*Function only available through password protection.*

If the current OSD Menu is in Simplified mode, you may gain access to all the functions again with the following procedure: Press the right (▶) to activate the function, now a requester will appear with 3 digits shown as: **0 0 0**.

To enable the OSD Menu to appear in Full Menu mode, please change the 3 digits to: **1 5 8** and press the right (▶) to confirm. Now all the Menu functions will be accessible. When you power off the product, this setting will be reverted back to Simplified mode.

*Note: To force the OSD Menu to appear in Full Menu Mode always, you must first unlock the OSD Menu with the procedure as described and then go to the [ Display / Setup / OSD Settings / OSD Mode / Full ] and make sure that setting is activated, see below.*

## Display / Setup / OSD Settings / OSD Mode / Simplified - May be set as factory default

*Function only available in "Full" menu mode.*

Force the OSD Menu to always appear in Simplified Mode (even after power shutdown of the unit). This means that a lot of advanced functions is not accessible from the OSD Menu. This is to prevent changes to the display that could impact on display functionality and image quality. Only experienced and qualified personnel should access and change this OSD Mode setting.

- When selected, a box icon (■) will indicate that the selected function has been activated.

## Display / Setup / OSD Settings / OSD Mode / Full - May be set as factory default

*Function only available in "Full" menu mode.*

Force the OSD Menu to always appear in Full Mode (even after power shutdown of the unit). This means that a lot of advanced functions is accessible from the OSD Menu. Only experienced and qualified personnel should access and change this OSD Mode setting. This is the factory default setting.

- When selected, a box icon (■) will indicate that the selected function has been activated.

## Display / Setup / OSD Settings / OSD Lock Mode / Normal - May be set as factory default

*Function only available in "Full" menu mode.*

Enables the user to enter OSD without any password protection. For Non-ECDIS Compliant usage.

- When selected, a box icon (■) will indicate that the selected function has been activated.

## OSD Menu Functions

### Display / Setup / OSD Settings / OSD Lock Mode / Password Protect - May be set as factory default

*Function only available in "Full" menu mode.*

Enables a password protection before getting access to the OSD menu. Required for ECDIS Compliance.

- When selected, a box icon (■) will indicate that the selected function has been activated.

When user now presses MENU, a requester will appear with 3 digits shown as: **0 0 0**

To enter the OSD Menu, please change the 3 digits to: **3 2 1** and press the right (▶) to confirm. If you cut power to the product, the password protection will still be active and the same password must be entered again to gain access.

### Display / Setup / User Settings / DPMS

Enable/disable the DPMS (VESA Display Power Management Signaling) function. DPMS is a standard from the VESA consortium for managing the power supply of display units for computers through the graphics card e.g; shut off the unit after the computer has been unused for some time (idle) to save power. Default is set to Enable (On).

- When selected, a box icon (■) will indicate that the selected function has been activated.

### Display / Setup / User Settings / Auto Source Select

Enable/disable the automatic detection and selection of any signal input and show it full screen. If you have a external unit that switches between several other external signal inputs of different signal origins, this function will be helpful and switch to the signal that appears to be valid since the last detection was made. If for instance a Composite Video Signal was terminated, the display controller would automatically scan the other available signal inputs and show that signal full screen instead. If that too is lost, it will continue to scan the other signal inputs. If no signal inputs were in the end found to be valid, the unit would eventually only show a black image and automatically power off (standby) due to inactivity (idle) in the signal streams. Default is set to Disable (Off).

- When selected, a box icon (■) will indicate that the selected function has been activated.

### Display / Setup / User Settings / Filter - Only available in customized solutions.

*Function only available in "Full" menu mode and when analog VGA/RGB signal are set as Main Source.*

Enable/disable the ARGB filter (Analog RGB) which is a Signal Noise Reduction technique to enhance a possible weak or bad RGB/VGA signal. It will remove certain types of noise patterns typically apparent in close proximity of other electronic equipment with less or lack of proper shielding to prevent interference. Default is set to Disable (Off).

- When selected, a box icon (■) will indicate that the selected function has been activated.



## OSD Menu Functions

### Display / Setup / User Settings / Communication / RS-232 - May be factory default.

*Function only available in "Full" menu mode.*

Configure the built-in HATTELAND® SCOM (Serial Remote Control Interface) to RS-232 protocol which enable software/remote control of a single HATTELAND® unit.

The SCOM will enable operators to modify a wide range of parameters available inside the display controller. Most of the functions described in this section is available, but also additional parameters can be inspected or adjusted with dedicated software connected to the unit's serial ports (COM). Daisy-chain operation is also possible by using a second COM port.

More in-depth information and usage about the SCOM, please visit: [www.hatteland-display.com](http://www.hatteland-display.com) "Product Support/Accessories/HATTELAND® SCOM Series 1" when made available.

- When selected, a box icon (  ) will indicate that the selected function has been activated.

### Display / Setup / User Settings / Communication / 2-wire RS-485 - May be factory default.

*Function only available in "Full" menu mode.*

Configure the built-in HATTELAND® SCOM (Serial Remote Control Interface) to RS-485 protocol which enable software/remote control of one or several other HATTELAND® units simultaneously.

- When selected, a box icon (  ) will indicate that the selected function has been activated.

### Display / Setup / User Settings / Communication / 4-wire RS-485/RS-422 - May be factory default.

*Function only available in "Full" menu mode.*

Configure the built-in HATTELAND® SCOM (Serial Remote Control Interface) to RS-485/RS-422 protocol which enable software/remote control of one or several other HATTELAND® units simultaneously.

- When selected, a box icon (  ) will indicate that the selected function has been activated.

### Display / Setup / User Settings / Communication / Address

*Function only available in "Full" menu mode.*

Configure the address which the current unit shall be identified as in a SCOM system. Whenever you communicate with the unit or units, the system will accept parameters or adjustments for that ID alone.

- Level adjust from 0-15 and reflects a unique ID number. Default is 0.

### Display / Setup / User Settings / Gamma / x.x

*Function only available in "Full" menu mode.*

Adjust the overall gamma intensity. You can choose 1.0 (default), 1.6 or 2.0. Higher values will give a much more brighter/washed out picture even in the darkest areas, i.e. black becomes faint grey. This affects the whole panel, and all applies to all signal inputs and window overlays (PIP/PBP) including the OSD Menu overlay. This will be independent of the actual brightness/contrast adjustment done by the front user controls like potmeters or buttons.

- When selected, a box icon (  ) will indicate that the selected function has been activated.

## OSD Menu Functions

### Display / Setup / User Settings / Splash Screen

*Function only available in "Full" menu mode.*

Enable/disable the Splash Screen logo upon power on for the unit and while the display controller is initializing. It will be gone as soon as the signal input appear on screen. This is by factory default shown as manufacturer's brand logo (HATTELAND®). This can also be customized to show customer logo.

### Display / Setup / Load Default / Factory Default

This function will reset everything to factory default settings. It will not revert back to a possible set of saved user defaults stored in the display controller software. All signal inputs and image adjustments will be reset. This function can be used in cases where you suspect a faulty or unsuitable configuration of the display is present. It can also be used in trouble-shooting situations to determine that the display are not or are the reason for a faulty or undesirable operation. The problem may be from external equipment.

- Press the right (▶) button to activate. A confirmation requester will appear. Use +/- to confirm.

### Display / Setup / Load Default / DDC Setup

*Function only available in "Full" menu mode.*

This function will detect the TFT panel specifications and update the DDC (Display Data Channel) for the display controller. It is to make sure the TFT panel's specifications can be detected successfully by the display controller software. This can be used in trouble-shooting situations to determine that the display are not or are the reason for a faulty or undesirable operation. The problem may be from external equipment.

- Press the right (▶) button to activate. A confirmation requester will appear. Use +/- to confirm.

### Display / Setup / Load Default / Load User Default

This function will restore any User Default settings that have been saved previously. If no User Defaults was found, nothing will be re-configured. The User Defaults consists of custom settings and all parameters adjusted in the entire OSD Menu by user. This can be used in trouble-shooting situations to determine that the display are not or are the reason for a faulty or undesirable operation. The problem may be from external equipment.

- Press the right (▶) button to activate. A confirmation requester will appear. Use +/- to confirm.

### Display / Setup / Load Default / Save User Default

*Function only available in "Full" menu mode.*

This function will create and save a own custom User Default based on what settings and parameters the user has edited in the OSD Menu. It will never save over the Factory Default, and it completely independent. This can also be useful for customers who want to specifically preset the OSD Menu after a certain company or usage/operation policy.

- Press the right (▶) button to activate. A confirmation requester will appear. Use +/- to confirm.

## OSD Menu Functions

### Display / Setup / Direct Access (also known as hotkey)

This function will configure the hotkey functionality. It means that the user can access a function that is normally only accessible by browsing through the OSD Menu and locate the function.

Available assigned hotkey functions are:

**Brightness, PIP Size, Main Source, Second Source, Alpha Blend, Video Scaling, Swap Source, Test Pattern, No Function.**

- When selected, a box icon (■) will indicate that the selected function has been activated.

### Display / Setup / Test Pattern

This function will show a typical test pattern with greyscales, colors and raster patterned boxes to check for deviations in the TFT panel/display controller behaviour. It is independent of any current resolution or specifications found in the signal inputs. The test pattern is generated internally in the display controller and is sent 1:1 directly to the TFT panel. It can be therefore be used in trouble-shooting situations to determine that the display are not or are the reason for a faulty or undesirable operation. The problem may be from external equipment. Also, this function will be handy to check the display quality without having any signal input available to test with.

- Press the right (▶) button to activate the function, and hold “MENU” key for 3 seconds exit the test.

### Display / Setup / Service Menu / Type and Serial

*Function only available in “Full” menu mode.*

This function will show the unit’s Type Number and Serial Number. This information is stored electronically on a board chip component. Example: “JH 23T12 MMD-AA1-AAAA-000001”

### Display / Setup / Service Menu / EVX Firmware Ver

*Function only available in “Full” menu mode.*

This function will show the firmware version (software OSD) of the display controller. This information is stored electronically on the EVX component board.

Example: “E0.30.00 1”.

### Display / Setup / Service Menu / ECOM Firmware Ver

*Function only available in “Full” menu mode.*

This will show the firmware version on the internal micro controller. This information is stored electronically on a board chip component. Example: “SW100062-1E5”.

### Display / Setup / Service Menu / Elapsed Time (hr)

*Function only available in “Full” menu mode.*

This function will show the current elapsed running time for the unit in hours. It is based on that the display has actually shown a valid image on screen during that time and not just how long the product has been powered on. It can be used to determine the life span in respect of what the MTBF for the display or backlight is specified to. This information is stored electronically on the EVX component board.

Example: “452”

# OSD Menu Functions

## Display / Setup / Service Menu / Fault Status

*Function only available in "Full" menu mode.*

This function will show the last recorded fault message detected by the display controller. This information is stored electronically on the EVX component board. Example: "Video Chip, DVI Chip, NVRAM, DDC"

## Display / Source / Single / xxx

This function will indicate what physical signal inputs is considered to be detectable by the OSD Menu and the display controller. The amount of signal inputs available will depend on the physical HATTELAND® IO Cable you have installed in the system. You can choose what sources are to be detectable and a icon next to each source will indicate its activity. When you for instance use the Swap Source function it will swap between all the indicated ones. Possible sources might include: **Analog RGB 1, Analog RGB 2, Digital (DVI), S-Video 1, S-Video 2, S-Video 3, Composite 1, Composite 2 and Composite 3.**

- When selected, a box icon ( ■ ) will indicate that the selected function has been activated.

## Display / Source / PIP / xxx

This function will indicate what physical signal inputs is considered to be detectable by the OSD Menu, the display controller and what is visible in the window overlay (Picture-In-Picture). The amount of signal inputs available will depend on the physical HATTELAND® Multifunction Cable you have connected to the unit. You can choose what sources are to be detectable and a icon next to each source will indicate its activity. When you for instance use the Swap Source/PIP function it will swap between all the indicated ones. Possible sources might include: **Analog RGB 1, Analog RGB 2, Digital (DVI), S-Video 1, S-Video 2, S-Video 3, Composite 1, Composite 2 and Composite 3.**

Note: This function is by factory default set to auto detect the signal source automatically. It means if you have **Composite 1** and **Composite 2** set as sources and you loose signal on Composite 1, the function will automatically switch to the next signal detectable, which in this example is **Composite 2**. If no signals are detectable the image will be black.

- When selected, a box icon ( ■ ) will indicate that the selected function has been activated.

## Display / Source / PBP / xxx

This function will indicate what physical signal inputs is considered to be detectable by the OSD Menu, the display controller and what is visible in the window overlay (Picture-By-Picture). The amount of signal inputs available will depend on the physical HATTELAND® Multifunction Cable you have connected to the unit. You can choose what sources are to be detectable and a icon next to each source will indicate its activity. When you for instance use the Swap Source/PBP function it will show two window overlays at the same time next to eachother. Possible sources might include: **Analog RGB 1, Analog RGB 2, Digital (DVI), S-Video 1, S-Video 2, S-Video 3, Composite 1, Composite 2 and Composite 3.**

Note: This function is by factory default set to auto detect the signal source automatically. It means if you have **Composite 1** and **Composite 2** set as sources and you loose signal on Composite 1, the function will automatically switch to the next signal detectable, which in this example is **Composite 2**. If no signals are detectable the image will be black.

- When selected, a box icon ( ■ ) will indicate that the selected function has been activated.

## OSD Menu Functions

### Display / Power Off

This function will turn off the unit (soft power off) and shut down the display controller and cut internal power to all components except the power module. The LED indicator ring/power leds will all illuminate red. The unit will enter standby mode. It does the same function as pressing the power button located on the user controls/front bezel. Please note that the power will still be present inside the unit because of the power cable is still physically connected to the power module.

- Press the right (▶) button to activate. A confirmation requester will appear. Use +/- to confirm.

This page left intentionally blank



# Specifications

# Specifications - JH 15T17 FUD-xAx-AOAA

Note: All specifications are subject to change without prior notice!

## TFT Technology:

- High Quality SHARP TFT
- 15.0 inch viewable image size
- Color Active Matrix LCD Module
- a-Si Thin Film Transistor (TFT)

## TFT Characteristics:

- Pixel Number : 1024 x 768
- Pixel Pitch (RGB) : 0.297 (H) x 0.297 (V) mm
- Response Time : 25 ms (typical), "black" to "white"
- Contrast Ratio : 400:1 (typical)
- Light Intensity : 250 cd/m<sup>2</sup> (typical)
- Viewable Angle : +/- 85 deg. (typical) (Up/Down/Left/Right)
- Active Display Area : 304.1 (H) x 228.1 (V) mm
- Max Colors : 16.7 millions

## Synchronisation:

### Sync Signal:

- Digital separate synchronisation
- Composite synchronisation
- Synchronisation on green.
- Auto detects VGA -> WUXGA, interlaced and non interlaced
- Video Signal : Analog RGB 0,7Vp-p  
: Input Impedance 75 Ohm

### Synchronisation Range:

- Horizontal : 15,0 kHz to 91,1 kHz
- Vertical : 60 Hz\* to 85 Hz

\* Recommended for optimum picture quality

## Supported Signals:

### Resolutions:

- VGA : 640 x 480 (including 640 x 350)
- SVGA : 800 x 600 (including 720 x 400)
- XGA : 1024 x 768\*
- SXGA : 1280 x 1024
- UXGA : 1600 x 1200
- WUXGA : 1920 x 1200

\* Recommended for optimum picture quality. (60 Hz only)

### Video Signals (with HATTELAND® Multifunction Cable):

- Interlaced NTSC and PAL/SECAM video
- Composite video

## Power Specifications:

### Power Supply:

- 115& 230VAC - 50 / 60Hz - JH 15T17 FUD-Axx-xxxx
- 24 VDC - JH 15T17 FUD-Dxx-xxxx

### Power Consumption:

Operating : 100 W (max)

## Typical Type Numbers:

- JH 15T17 FUD-AA1-AOAA = Standard AC, Keypad, Bonded
- JH 15T17 FUD-DA1-AOAA = Standard DC, Keypad, Bonded

## Physical Considerations:

- 412 (W) x 345 (H) x 73 (D) mm / 16.22" (W) x 13.58" (H) x 2.87" (D)
- Weight: 7 kg (approx)

## Signal Terminals:

- DVI-I Signal IN : 1 x 29p DVI Female (or as RGB IN with adapter)
- RGB Signal IN : 1 x 15p HD D-SUB (female)
- RGB Signal OUT : 1 x 15p HD D-SUB (female) - Clone of RGB IN\*\*
- Multifunction : 1 x 160p D-SUB (female) - Also see table below
- USB I/O : 1 x TYPE B Conn. (female) Reserved for future use
- AC Power IN : 1 x Std IEC Inlet
- AC Power OUT : 1 x Std IEC Outlet
- DC Power IN : 1 x 2p D-SUB Connector (male) - Amphenol FCC17

\*\*Tested at recommended resolutions. The RGB output signal is at same resolution and sync as the RGB input. The output is working even if the display unit is turned off, but power cable/supply must be connected/provided.

## HATTELAND® Multifunction Cable:

The factory standard cable is delivered with the following connectors. Standard cable length is 30cm. Art: #1=VSD100692-4 / #2=VSD100692-3

#1	• COM1	: 1 x 9p D-SUB (female) - RS232
	• Composite Video IN	: 3 x BNC (female)
#2	• COM1	: 1 x 9p D-SUB (female) - RS232
	• Composite Video IN	: 3 x BNC (female)
	• COM Touch	: 1 x 9p D-SUB (female) - For touch screen

Customized cables are possible to support more built-in signals, like: RS-232, RS-485, RS-422/RS-485, Buzzer, ON/OFF, Touch (RS-232 or PS/2), 1 x S-Video IN, 3 x Composite Video IN, Remote External User Controls, Alternative Keypad interface (i2c) and reserved for other signals. Custom cable lengths can be manufactured.

## User Controls:

### On front bezel - Keypad control (IP66) xxx-xxAx models:

- Power On/Off and On Screen Display Menu (push button)
- Control (up/down - push buttons)
- Hotkeys (left/right - push buttons)
- Mode Status Red/Green Illuminated LED-Ring Indicator

## Environmental Considerations:

- Operating : Temperature -15 deg. C to +55 deg. C  
: Humidity up to 95%
- Storage : Temperature -20 deg. C to +60 deg. C  
: Humidity up to 95%
- IP Rating : EN60529 (IP66) (Applies for flush mount)
- Compass Safe Dist. : JH15T17FUD-xAx-AOAA - Std:130cm Steering:100cm

### Safety Considerations:

Even although the test conditions for bridge units provide for a maximum operating temperature of 55°C, continuous operation of all electronic components should, if possible, take place at ambient temperatures of only 25°C. This is a necessary prerequisite for long life and low service costs.

## Available Accessories:

- Cables = Custom Multifunction Cable to support more signals
- JH 15TBR STD-B1 = Mounting Bracket (Review user manual)
- JH 15TRO STD-A1 = Rotary Bracket (Review user manual)
- JH 15TSV STD-A1 = Sun Visor (Review user manual)
- JH VESA 15T03-A1= Vesa Bracket (Review user manual)
- JH 15TAP STD-A1 = 15" Adapter Frame to 19" Rack (Review user manual)
- JH 15TAP STD-B1 = 15" Adapter Frame to 17" CRT monitor (Review man)
- JH 15TWC STD-A1= Water Cover (Review user manual)

## TESTING / APPROVALS & CERTIFICATES

This product have been tested / type approved by the following classification societies:  
**EN60945 4th** (IEC945 4th)      **ClassNK** - Nippon Kaiji Kyokai      **GL** - Germanischer Lloyd      **DNV** - Det Norske Veritas  
**ABS** - American Bureau of Shipping      **BV** - Bureau Veritas      **CCS** - China Classification Society



# Specifications - JH 19T14 FUD-xAx-AOAA

Note: All specifications are subject to change without prior notice!

## TFT Technology:

- High Quality SHARP TFT
- 19.0 inch viewable image size
- Active Matrix, Thin Film Transistor (TFT)
- MVA Premium™ Technology

## TFT Characteristics:

- Pixel Number : 1280 x 1024
- Pixel Pitch (RGB) : 0.294 (H) x 0.294 (V) mm
- Response Time : 12 ms (typical), "black" to "white"
- Contrast Ratio : 900:1 (typical)
- Light Intensity : 300 cd/m2 (typical)
- Viewable Angle : +/- 85 deg. (typical) (Up/Down/Left/Right)
- Active Display Area : 376.32 (H) x 301.056 (V) mm
- Max Colors : 16.7 millions

## Synchronisation:

### Sync Signal:

- Digital separate synchronisation
- Composite synchronisation
- Synchronisation on green.
- Auto detects VGA -> WUXGA, interlaced and non interlaced
- Video Signal : Analog RGB 0,7Vp-p  
: Input Impedance 75 Ohm

### Synchronisation Range:

- Horizontal : 15,0 kHz to 91,1 kHz
- Vertical : 60 Hz\* to 85 Hz

\* Recommended for optimum picture quality

## Supported Signals:

### Resolutions:

- VGA : 640 x 480 (including 640 x 350)
- SVGA : 800 x 600 (including 720 x 400)
- XGA : 1024 x 768
- SXGA : 1280 x 1024\*
- UXGA : 1600 x 1200
- WUXGA : 1920 x 1200

\* Recommended for optimum picture quality. (60 Hz only)

### Video Signals (with HATTELAND® Multifunction Cable):

- Interlaced NTSC and PAL/SECAM video
- Composite video

## Power Specifications:

### Power Supply:

- 115& 230VAC - 50 / 60Hz - JH 19T14 FUD-Axx-xxxx
- 24 VDC - JH 19T14 FUD-Dxx-xxxx

### Power Consumption:

Operating : 100 W (max)

## Typical Type Numbers:

- JH 19T14 FUD-AA1-AOAA = Standard AC, Keypad, Bonded
- JH 19T14 FUD-DA1-AOAA = Standard DC, Keypad, Bonded

## Physical Considerations:

- 483 (W) x 444 (H) x 82 (D) mm / 19.02" (W) x 17.48" (H) x 3.23" (D)
- Weight: 11.50 kg (approx)

## Signal Terminals:

- DVI-I Signal IN : 1 x 29p DVI Female (or as RGB IN with adapter)
- RGB Signal IN : 1 x 15p HD D-SUB (female)
- RGB Signal OUT : 1 x 15p HD D-SUB (female) - Clone of RGB IN\*\*
- Multifunction : 1 x 160p D-SUB (female) - Also see table below
- USB I/O : 1 x TYPE B Conn. (female) Reserved for future use
- AC Power IN : 1 x Std IEC Inlet
- AC Power OUT : 1 x Std IEC Outlet
- DC Power IN : 1 x 2p D-SUB Connector (male) - Amphenol FCC17

\*\*Tested at recommended resolutions. The RGB output signal is at same resolution and sync as the RGB input. The output is working even if the display unit is turned off, but power cable/supply must be connected/provided.

## HATTELAND® Multifunction Cable:

The factory standard cable is delivered with the following connectors. Standard cable length is 30cm. Art: #1=VSD100692-4 / #2=VSD100692-3

#	Signal	Connector
#1	• COM1	: 1 x 9p D-SUB (female) - RS232
	• Composite Video IN	: 3 x BNC (female)
#2	• COM1	: 1 x 9p D-SUB (female) - RS232
	• Composite Video IN	: 3 x BNC (female)
	• COM Touch	: 1 x 9p D-SUB (female) - For touch screen

Customized cables are possible to support more built-in signals, like: RS-232, RS-485, RS-422/RS-485, Buzzer, ON/OFF, Touch (RS-232 or PS/2), 1 x S-Video IN, 3 x Composite Video IN, Remote External User Controls, Alternative Keypad interface (i2c) and reserved for other signals. Custom cable lengths can be manufactured.

## User Controls:

### On front bezel - Keypad control (IP66) xxx-xxAx models:

- Power On/Off and On Screen Display Menu (push button)
- Control (up/down - push buttons)
- Hotkeys (left/right - push buttons)
- Mode Status Red/Green Illuminated LED-Ring Indicator

## Environmental Considerations:

- Operating : Temperature -15 deg. C to +55 deg. C  
: Humidity up to 95%
- Storage : Temperature -20 deg. C to +60 deg. C  
: Humidity up to 95%
- IP Rating : EN60529 (IP66) (Applies for flush mount)
- Compass Safe Dist. : JH19T14FUD-xAx-AOAA - Std:1.60m Steering:1.05m

### Safety Considerations:

Even although the test conditions for bridge units provide for a maximum operating temperature of 55°C, continuous operation of all electronic components should, if possible, take place at ambient temperatures of only 25°C. This is a necessary prerequisite for long life and low service costs.

## Available Accessories:

- Cables = Custom Multifunction Cable to support more signals
- JH MMD BR = Bracket (Review bracket datasheet/user manual)
- JH 19BRD STD-A1 = Mounting Bracket EN60945 Tested
- JH MMDROSTD-A1 = Rotary Bracket (Review bracket datasheet/manual)
- JH 19TSV STD-A1 = Sun Visor (Review user manual)
- JH VESA 18T04 = Vesa Bracket (Review user manual)
- JH 19TAP STD-A1 = 19" to 21" CRT Adapter frame (Review user manual)
- JH 19TWC STD-B1 = Water Cover (Review user manual)

## TESTING / APPROVALS & CERTIFICATES

This product have been tested / type approved by the following classification societies:

EN60945 4th (IEC945 4th)

DNV - Det Norske Veritas

CCS - China Classification Society

ClassNK - Nippon Kaiji Kyokai

ABS - American Bureau of Shipping

GL - Germanischer Lloyd

BV - Bureau Veritas

# Specifications - JH 20T17 FUD-xAx-AOAA

Note: All specifications are subject to change without prior notice!

## TFT Technology:

- High Quality SHARP TFT
- 20.1 inch viewable image size
- a-Si TFT (Thin Film Transistor) Active Matrix

## TFT Characteristics:

- Pixel Number : 1600 x 1200
- Pixel Pitch (RGB) : 0.255 (H) x 0.255 (V) mm
- Response Time : 20 ms (typical), rise + fall
- Contrast Ratio : 500:1 (typical)
- Light Intensity : 250 cd/m2 (typical)
- Viewable Angle : +/- 88 deg. (typical) (Up/Down/Left/Right)
- Active Display Area : 408.0 (H) x 306.0 (V) mm
- Max Colors : 16.7 millions

## Synchronisation:

### Sync Signal:

- Digital separate synchronisation
- Composite synchronisation
- Synchronisation on green.
- Auto detects VGA -> WUXGA, interlaced and non interlaced
- Video Signal : Analog RGB 0,7Vp-p  
: Input Impedance 75 Ohm

### Synchronisation Range:

- Horizontal : 15,0 kHz to 91,1 kHz
- Vertical : 60 Hz\* to 85 Hz

\* Recommended for optimal picture quality

## Supported Signals:

### Resolutions:

- VGA : 640 x 480 (including 640 x 350)
- SVGA : 800 x 600 (including 720 x 400)
- XGA : 1024 x 768
- SXGA : 1280 x 1024
- UXGA : 1600 x 1200\*
- WUXGA : 1920 x 1200

\* Recommended for optimum picture quality. (60 Hz only)

### Video Signals (with HATTELAND® Multifunction Cable):

- Interlaced NTSC and PAL/SECAM video
- Composite video

## Power Specifications:

### Power Supply:

- 115 & 230VAC - 50 / 60Hz - JH 20T17 FUD-Axx-xxxx
- 24 VDC - JH 20T17 FUD-Dxx-xxxx

### Power Consumption:

- Operating : 100 W (max)

## Typical Type Numbers:

- JH 20T17 FUD-AA1-AOAA = Standard AC, Keypad, Bonded
- JH 20T17 FUD-DA1-AOAA = Standard DC, Keypad, Bonded

## Physical Considerations:

- 534 (W) x 481 (H) x 87 (D) mm - 21.02" (W) x 18.93" (H) x 3.42" (D)
- Weight: 13.50 kg (approx)

## Signal Terminals:

- DVI-I Signal IN : 1 x 29p DVI Female (or as RGB IN with adapter)
- RGB Signal IN : 1 x 15p HD D-SUB (female)
- RGB Signal OUT : 1 x 15p HD D-SUB (female) - Clone of RGB IN\*\*
- Multifunction : 1 x 160p D-SUB (female) - Also see table below
- USB I/O : 1 x TYPE B Conn. (female) Reserved for future use
- AC Power IN : 1 x Std IEC Inlet
- AC Power OUT : 1 x Std IEC Outlet
- DC Power IN : 1 x 2p D-SUB Connector (male) - Amphenol FCC17

\*\*Tested at recommended resolutions. The RGB output signal is at same resolution and sync as the RGB input. The output is working even if the display unit is turned off, but power cable/supply must be connected/provided.

## HATTELAND® Multifunction Cable:

The factory standard cable is delivered with the following connectors. Standard cable length is 30cm. Art: #1=VSD100692-4 / #2=VSD100692-3

#	Signal	Connector
#1	• COM1	: 1 x 9p D-SUB (female) - RS232
	• Composite Video IN	: 3 x BNC (female)
#2	• COM1	: 1 x 9p D-SUB (female) - RS232
	• Composite Video IN	: 3 x BNC (female)
	• COM Touch	: 1 x 9p D-SUB (female) - For touch screen

Customized cables are possible to support more built-in signals, like: RS-232, RS-485, RS-422/RS-485, Buzzer, ON/OFF, Touch (RS-232 or PS/2), 1 x S-Video IN, 3 x Composite Video IN, Remote External User Controls, Alternative Keypad interface (i2c) and reserved for other signals. Custom cable lengths can be manufactured.

## User Controls:

### On front bezel - Keypad control (IP66) xxx-xxAx models:

- Power On/Off and On Screen Display Menu (push button)
- Control (up/down - push buttons)
- Hotkeys (left/right - push buttons)
- Mode Status Red/Green Illuminated LED-Ring Indicator

## Environmental Considerations:

- Operating : Temperature -15 deg. C to +55 deg. C  
- Humidity up to 95%
- Storage : Temperature -20 deg. C to +60 deg. C  
- Humidity up to 95%
- IP Rating : EN60529 (IP66) (Applies for flush mount)
- Compass Safe Dist. : JH20T17MMD--xAx-AOAA - Std:75cm Steering:35cm

### Safety Considerations:

Even although the test conditions for bridge units provide for a maximum operating temperature of 55°C, continuous operation of all electronic components should, if possible, take place at ambient temperatures of only 25°C. This is a necessary prerequisite for long life and low service costs.

## Available Accessories:

- Cables = Custom Multifunction Cable to support more signals
- JH MMDBRSTD-A1= Bracket (Review bracket datasheet/user manual)
- JH MMDROSTD-A1= Rotary Bracket (Review bracket datasheet/manual)
- JH 20TSVSTD-B1 = Sun Visor (Review user manual)
- JH VESA20T06-A1 = Vesa Bracket (Review user manual)
- JH 20TWCSTD-B1 = Water Cover (Review user manual)

## TESTING / APPROVALS & CERTIFICATES

EN60945 4th (IEC945 4th)

DNV - Det Norske Veritas

CCS - China Classification Society

This product have been tested / type approved by the following classification societies:

ClassNK - Nippon Kaiji Kyokai

ABS - American Bureau of Shipping

GL - Germanischer Lloyd

BV - Bureau Veritas

# Specifications - JH 23T12 FUD-xAx-AOAA

Note: All specifications are subject to change without prior notice!

## TFT Technology:

- High Quality SHARP TFT
- 23.1 inch viewable image size
- TFT active-matrix liquid crystal panel
- MVA (Multi-domain Vertical Alignment) LCD Technology

## TFT Characteristics:

- Pixel Number : 1600 x 1200
- Pixel Pitch (RGB) : 0.294 (H) x 0.294 (V) mm
- Response Time : 20 ms (typical), "black" to "white"
- Contrast Ratio : 500:1 (typical)
- Light Intensity : 250 cd/m2 (typical)
- Viewable Angle : +/- 85 deg. (typical) (Up/Down/Left/Right)
- Active Display Area : 470.4 (H) x 352.8 (V) mm
- Max Colors : 16.7 millions

## Synchronisation:

### Sync Signal:

- Digital separate synchronisation
- Composite synchronisation
- Synchronisation on green.
- Auto detects VGA -> WUXGA, interlaced and non interlaced
- Video Signal : Analog RGB 0,7Vp-p  
: Input Impedance 75 Ohm

### Synchronisation Range:

- Horizontal : 15,0 kHz to 91,1 kHz
- Vertical : 60 Hz\* to 85 Hz

\* Recommended for optimum picture quality

## Supported Signals:

### Resolutions:

- VGA : 640 x 480 (including 640 x 350)
- SVGA : 800 x 600 (including 720 x 400)
- XGA : 1024 x 768
- SXGA : 1280 x 1024
- UXGA : 1600 x 1200\*
- WUXGA : 1920 x 1200

\* Recommended for optimum picture quality. (60 Hz only)

### Video Signals (with HATTELAND® Multifunction Cable):

- Interlaced NTSC and PAL/SECAM video
- Composite video

## Power Specifications:

### Power Supply:

- 115 & 230VAC - 50 / 60Hz - JH 23T12 FUD-Axx-xxxx

### Power Consumption:

- Operating : 90W (TYP) - 200W (MAX)

## Typical Type Numbers:

- JH 23T12 FUD-AA1-AOAA = Standard AC, Keypad, Bonded
- JH 23T12 FUD-DA1-AOAA = Standard DC, Keypad, Bonded

## Physical Considerations:

- 584 (W) x 534 (H) x 85 (D) mm - 22.99" (W) x 21.02" (H) x 3.35" (D)
- Weight: 20 kg (approx)

## Signal Terminals:

- DVI-I Signal IN : 1 x 29p DVI Female (or as RGB IN with adapter)
- RGB Signal IN : 1 x 15p HD D-SUB (female)
- RGB Signal OUT : 1 x 15p HD D-SUB (female) - Clone of RGB IN\*\*
- Multifunction : 1 x 160p D-SUB (female) - Also see table below
- USB I/O : 1 x TYPE B Conn. (female) Reserved for future use
- AC Power IN : 1 x Std IEC Inlet
- AC Power OUT : 1 x Std IEC Outlet

\*\*Tested at recommended resolutions. The RGB output signal is at same resolution and sync as the RGB input. The output is working even if the display unit is turned off, but power cable/supply must be connected/provided.

## HATTELAND® Multifunction Cable:

The factory standard cable is delivered with the following connectors.  
Standard cable length is 30cm. Art: #1=VSD100692-4 / #2=VSD100692-3

#1	• COM1	: 1 x 9p D-SUB (female) - RS232
	• Composite Video IN	: 3 x BNC (female)
#2	• COM1	: 1 x 9p D-SUB (female) - RS232
	• Composite Video IN	: 3 x BNC (female)
	• COM Touch	: 1 x 9p D-SUB (female) - For touch screen

Customized cables are possible to support more built-in signals, like: RS-232, RS-485, RS-422/RS-485, Buzzer, ON/OFF, Touch (RS-232 or PS/2), 1 x S-Video IN, 3 x Composite Video IN, Remote External User Controls, Alternative Keypad interface (i2c) and reserved for other signals. Custom cable lengths can be manufactured.

## User Controls:

### On front bezel - Keypad control (IP66) xxx-xxAx models:

- Power On/Off and On Screen Display Menu (push button)
- Control (up/down - push buttons)
- Hotkeys (left/right - push buttons)
- Mode Status Red/Green Illuminated LED-Ring Indicator

## Environmental Considerations:

- Operating : Temperature -15 deg. C to +55 deg. C  
- Humidity up to 95%
- Storage : Temperature -20 deg. C to +60 deg. C  
- Humidity up to 95%
- IP Rating : EN60529 (IP66) (Applies for flush mount)
- Compass Safe Dist. : JH23T12FUD-xAx-AOAA - Std:1.60m Steering:1.05m

### Safety Considerations:

Even although the test conditions for bridge units provide for a maximum operating temperature of 55°C, continuous operation of all electronic components should, if possible, take place at ambient temperatures of only 25°C. This is a necessary prerequisite for long life and low service costs.

## Available Accessories:

- Cables = Custom Multifunction Cable to support more signals
- JH 23TBR T01-A1 = Bracket (Review bracket datasheet/user manual)
- JH 23BRD STD-A1 = Mounting Bracket EN60945 Tested
- JH MMDROSTD-A1 = Rotary Bracket (Review bracket datasheet/manual)
- JH 23TSV STD-A1 = Sun Visor (Review user manual)
- JH VESA 23T01-A1 = Vesa Bracket (Review user manual)
- JH 23TWC STD-B1 = Water Cover (Review user manual)

## TESTING / APPROVALS & CERTIFICATES

EN60945 4th (IEC945 4th)  
DNV - Det Norske Veritas  
BV - Bureau Veritas

This product have been tested / type approved by the following classification societies:

ClassNK - Nippon Kaiji Kyokai  
ABS - American Bureau of Shipping  
CCS - China Classification Society

GL - Germanischer Lloyd  
LRS - Lloyd's Register of Shipping

This page left intentionally blank



# Technical Drawings

# Technical Drawings - JH 15T17 FUD-xAx-AOAA

Dimensions might be shown with or without decimals and indicated as mm [inches]. Tolerance on drawings is +/- .1mm. For accurate measurements, check relevant DWG file.

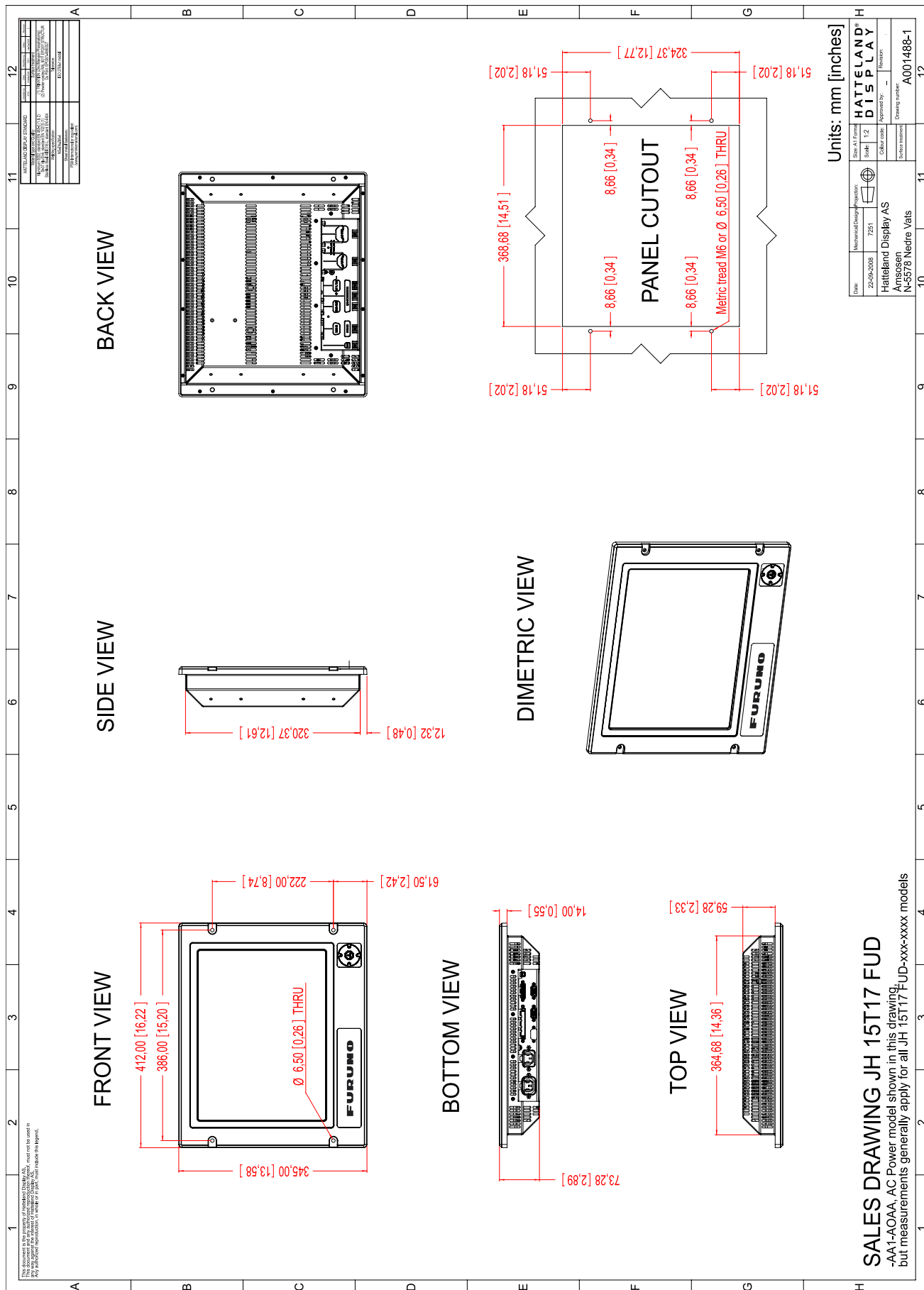

## SALES DRAWING JH 15T17 FUD

-AA1-AOAA, AC Power model shown in this drawing, but measurements generally apply for all JH 15T17 FUD-xxx-xxxx models

This document is the property of Hatteland Display AS. This document and any authorized reproduction thereof, must not be used in any way against the interest of Hatteland Display AS. Any authorized reproduction, in whole or in part, must include this legend. Hatteland Display Proprietary information. Not to be distributed to any third party without written permission.

# Technical Drawings - JH 19T14 FUD-xAx-AOAA

Dimensions might be shown with or without decimals and indicated as mm [inches]. Tolerance on drawings is +/- .1mm. For accurate measurements, check relevant DWG file.

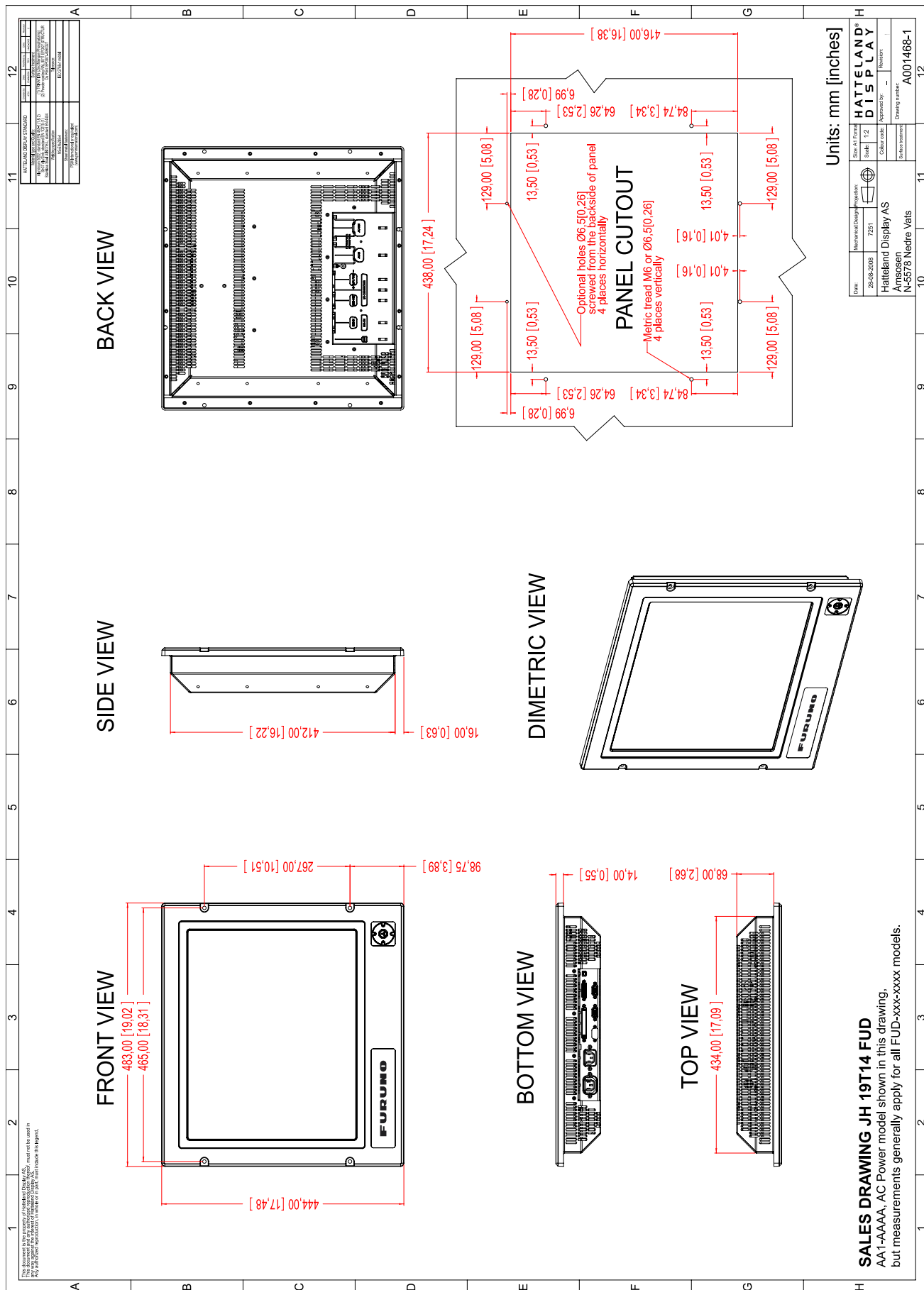

**SALES DRAWING JH 19T14 FUD**  
 AA1-AAAA, AC Power model shown in this drawing.  
 but measurements generally apply for all FUD-xxx-xxxx models.

This document is the property of HatteLand Display AS. This document and any authorized reproduction thereof, must not be used in any way against the interest of HatteLand Display AS. Any authorized reproduction, in whole or in part, must include this legend. HatteLand Display Proprietary information. Not to be distributed to any third party without written permission.

# Technical Drawings - JH 20T17 FUD-xAx-AOAA

Dimensions might be shown with or without decimals and indicated as mm [inches]. Tolerance on drawings is +/- .1mm. For accurate measurements, check relevant DWG file.

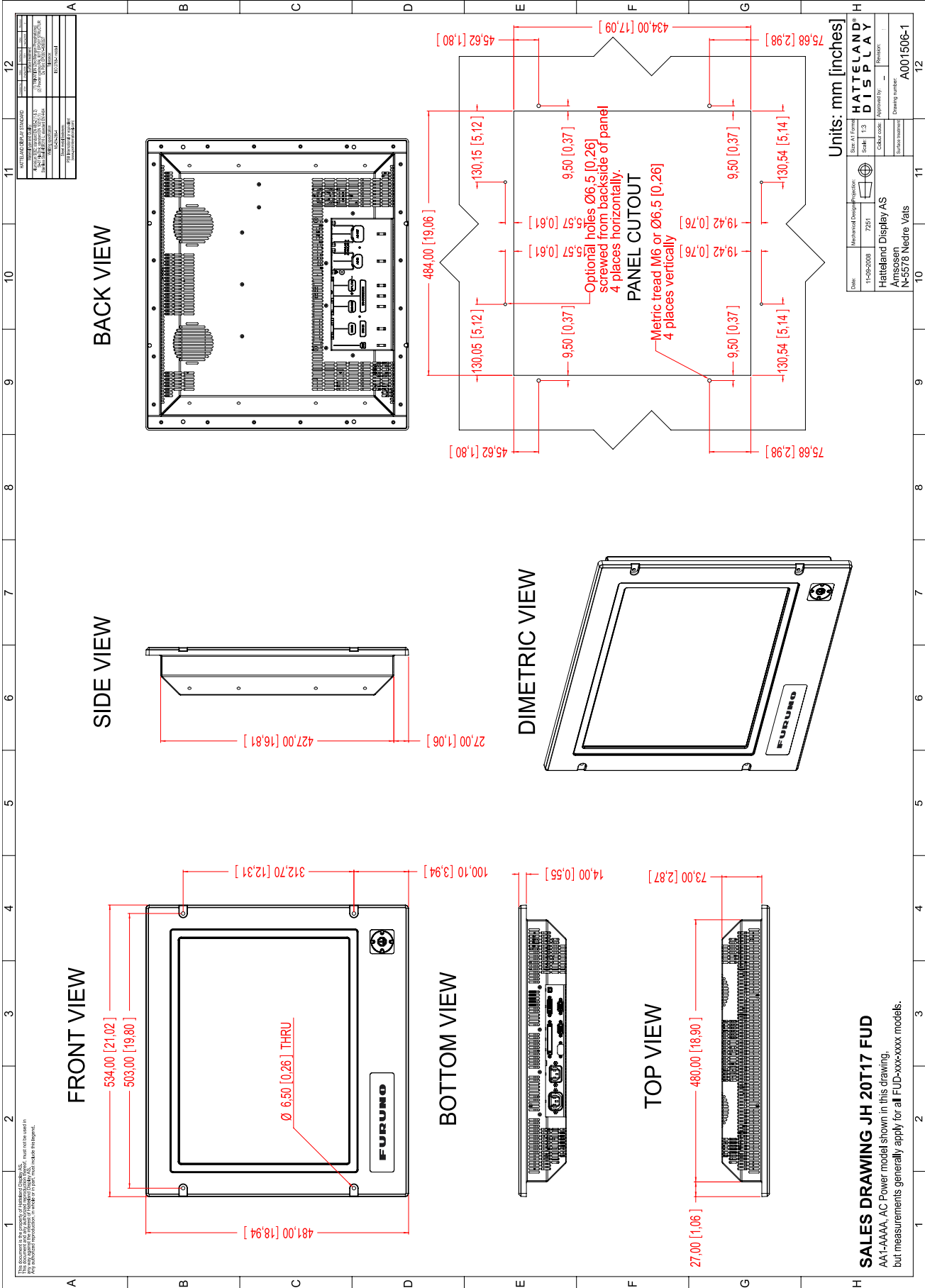

**SALES DRAWING JH 20T17 FUD**  
 AA1-AAAA, AC Power model shown in this drawing,  
 but measurements generally apply for all FUD-xx-xxxx models.

This document is the property of Hatteland Display AS. This document and any authorized reproduction thereof, must not be used in any way against the interest of Hatteland Display AS. Any authorized reproduction, in whole or in part, must include this legend. Hatteland Display Proprietary information. Not to be distributed to any third party without written permission.



# Technical Drawings - JH 23T12 FUD-xAx-AOAA

Dimensions might be shown with or without decimals and indicated as mm [inches]. Tolerance on drawings is +/- .1mm. For accurate measurements, check relevant DWG file.

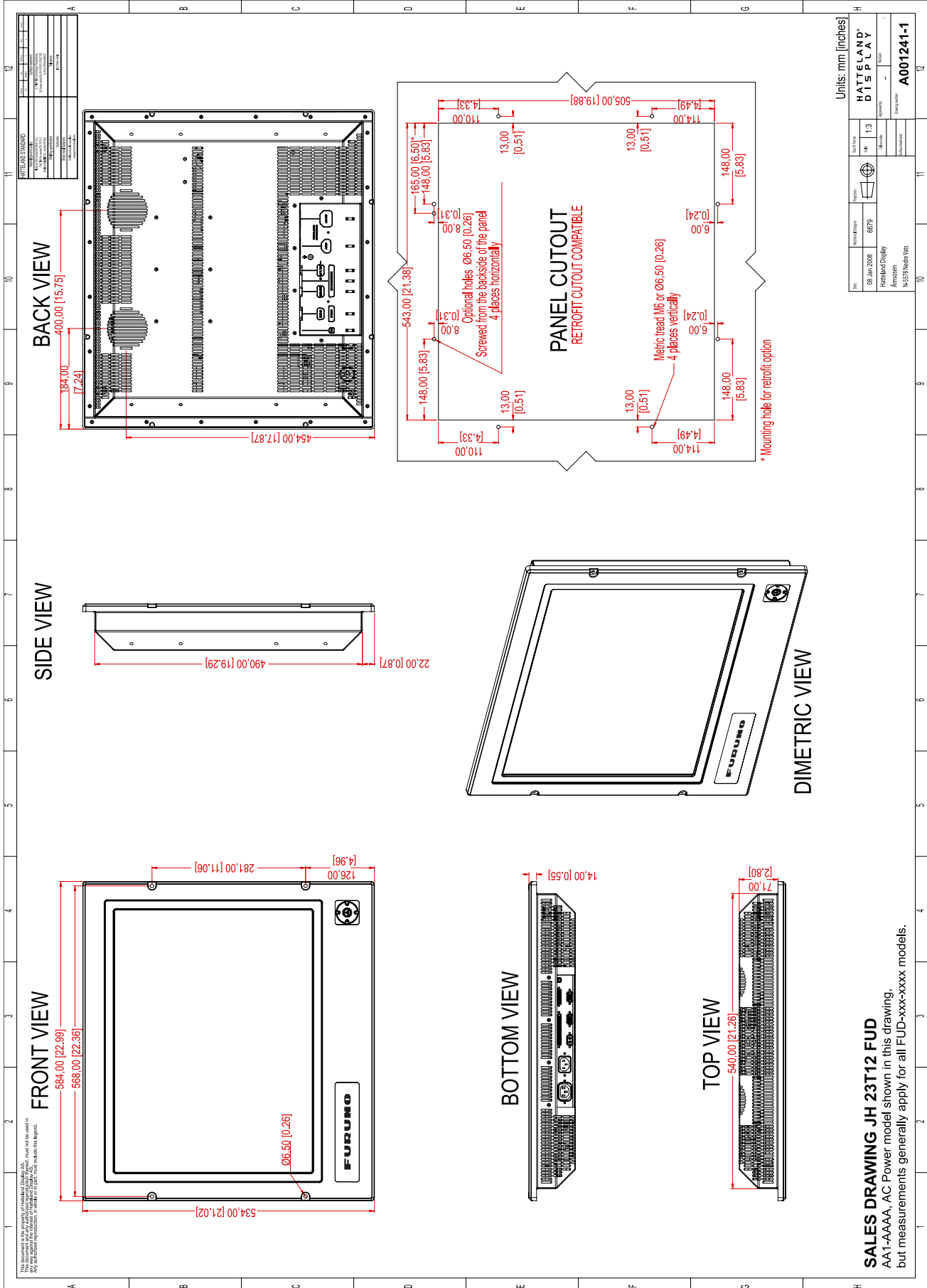

**SALES DRAWING JH 23T12 FUD**  
 AA1-AAAA, AC Power model shown in this drawing,  
 but measurements generally apply for all FUD-xxx-xxxx models.

This document is the property of Hatteland Display AS. This document and any authorized reproduction thereof, must not be used in any way against the interest of Hatteland Display AS. Any authorized reproduction, in whole or in part, must include this legend. Hatteland Display Proprietary information. Not to be distributed to any third party without written permission.

This page left intentionally blank



# **Technical Drawings - Accessories**

# Technical Drawings - Accessories

Dimensions might be shown with or without decimals and indicated as mm [inches]. Tolerance on drawings is +/- 1mm. For accurate measurements, check relevant DWG file.

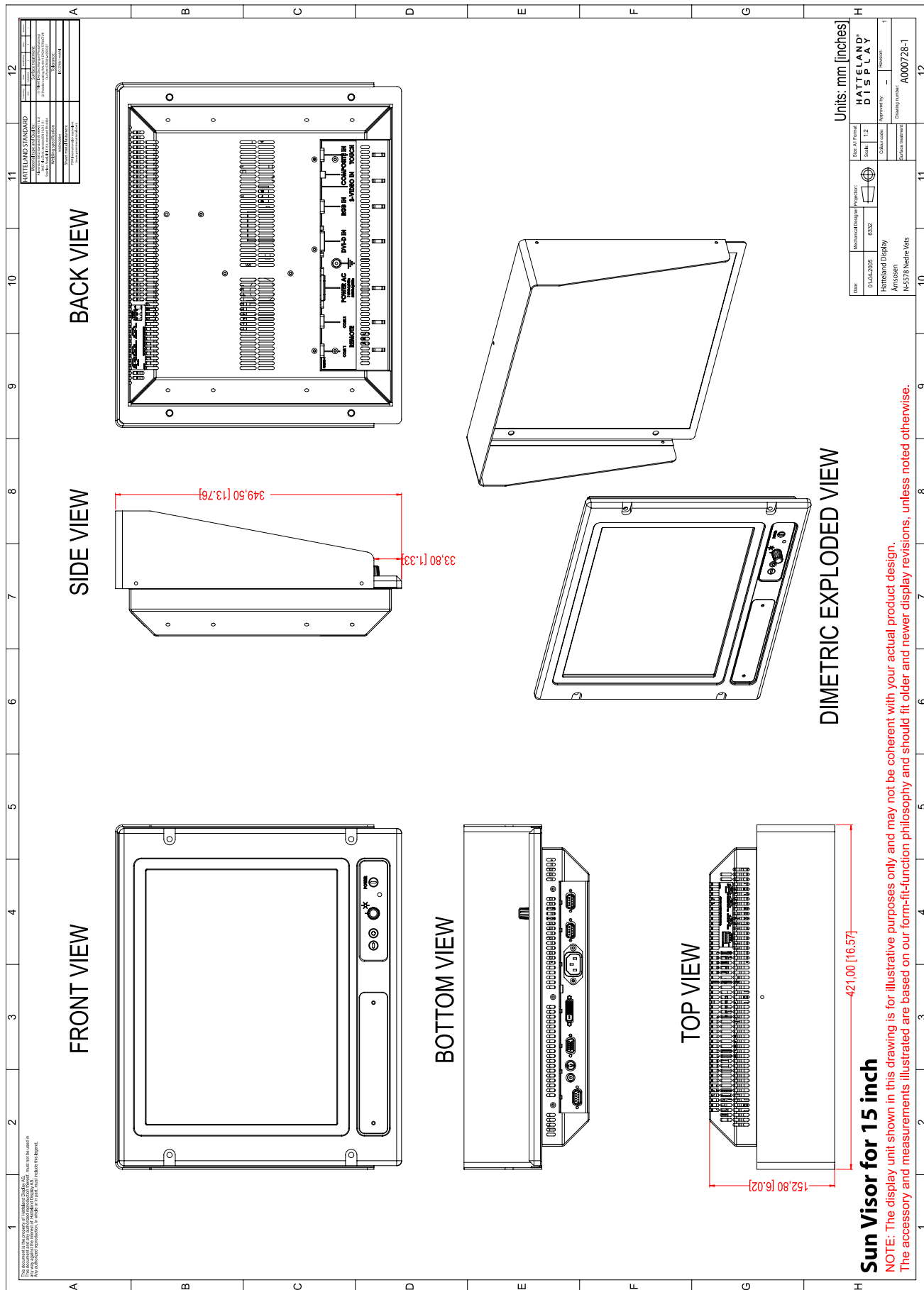

This document is the property of Hatteland Display AS. This document and any authorized reproduction thereof, must not be used in any way against the interest of Hatteland Display AS. Any authorized reproduction, in whole or in part, must include this legend. Hatteland Display Proprietary information. Not to be distributed to any third party without written permission.

# Technical Drawings - Accessories

Dimensions might be shown with or without decimals and indicated as mm [inches]. Tolerance on drawings is +/- 1mm. For accurate measurements, check relevant DWG file.

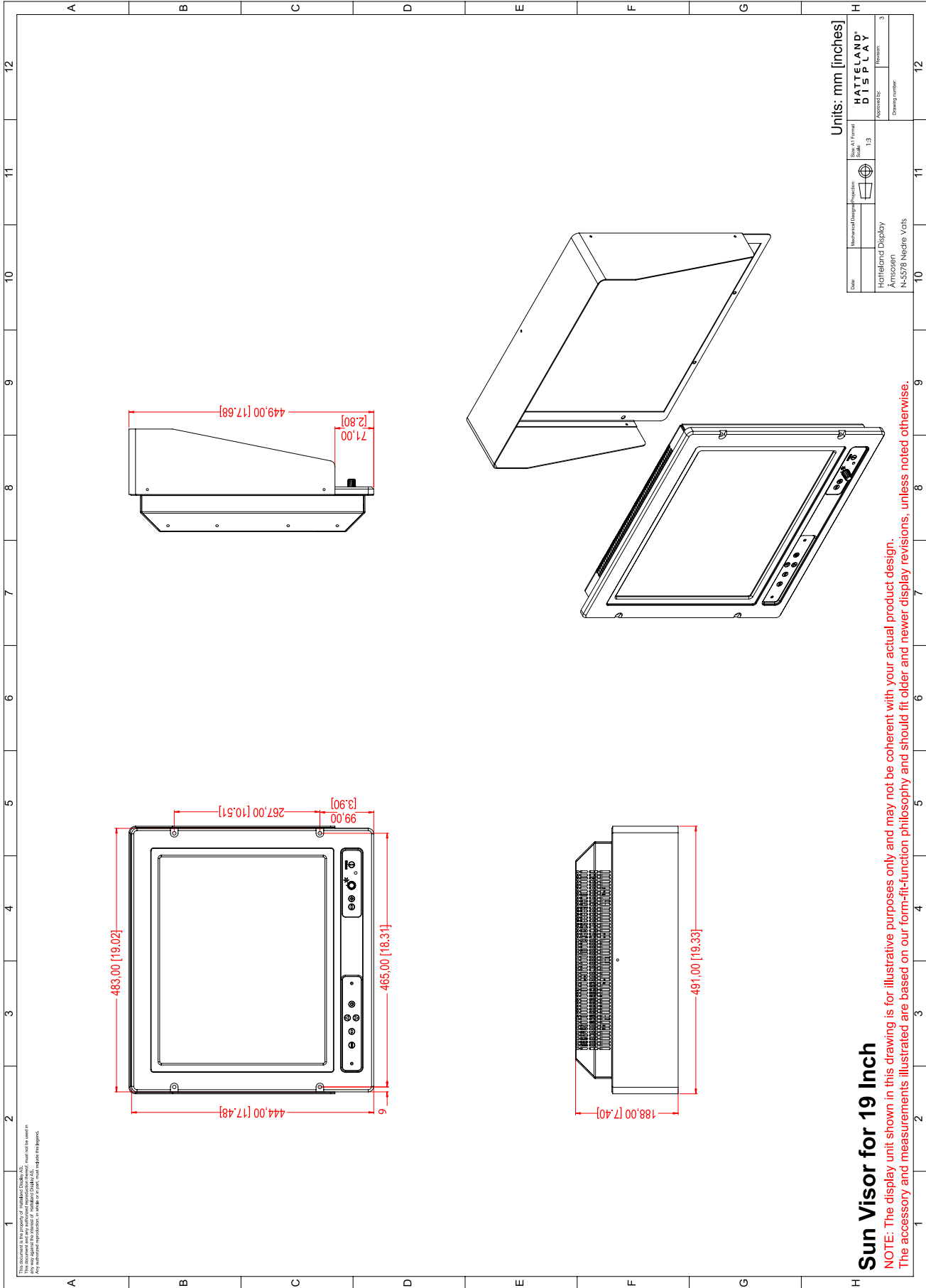

This document is the property of Hatteland Display AS. This document and any authorized reproduction thereof, must not be used in any way against the interest of Hatteland Display AS. Any authorized reproduction, in whole or in part, must include this legend. Hatteland Display Proprietary information. Not to be distributed to any third party without written permission.

# Technical Drawings - Accessories

Dimensions might be shown with or without decimals and indicated as mm [inches]. Tolerance on drawings is +/- 1mm. For accurate measurements, check relevant DWG file.

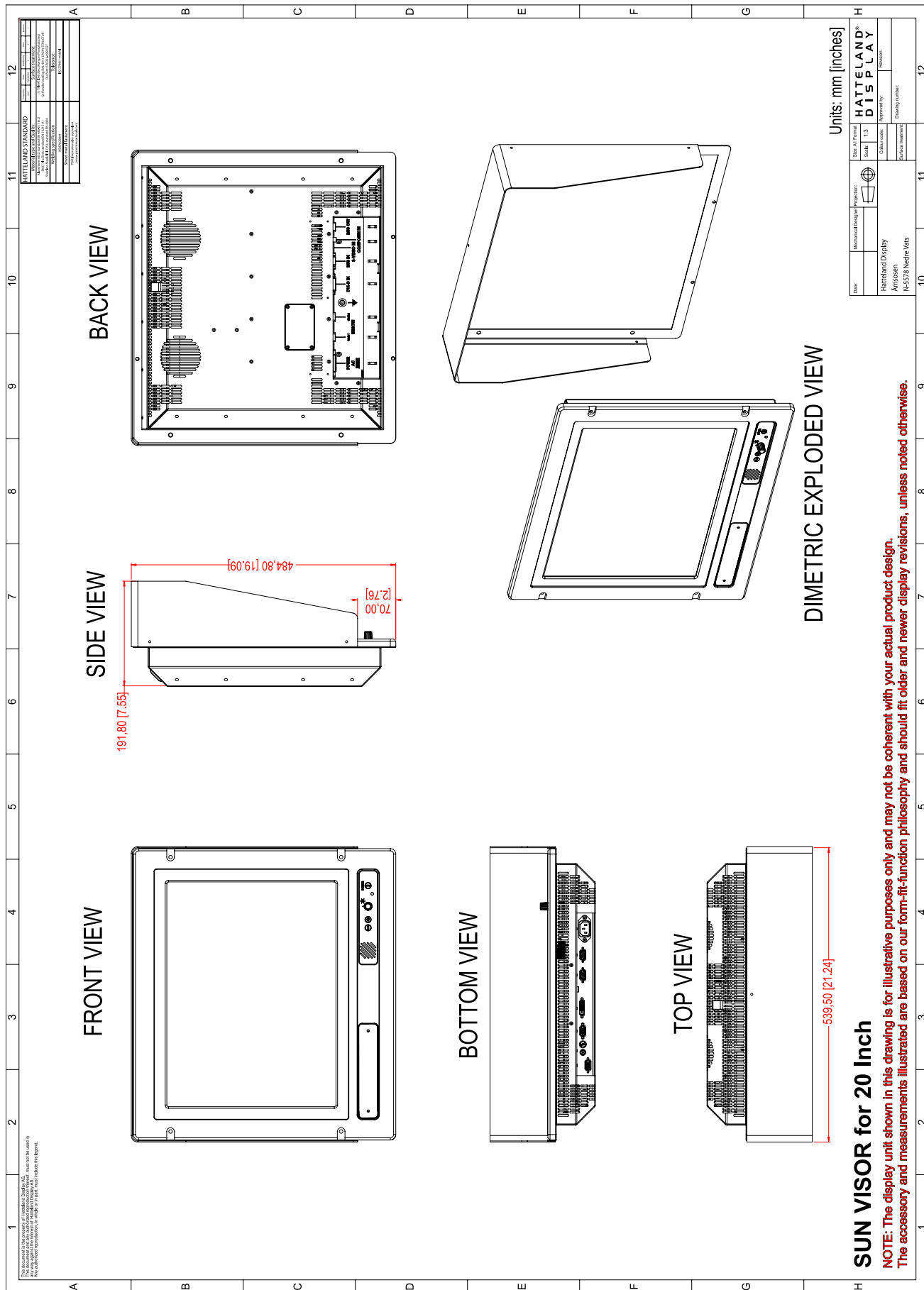

This document is the property of Hatteland Display AS. This document and any authorized reproduction thereof, must not be used in any way against the interest of Hatteland Display AS. Any authorized reproduction, in whole or in part, must include this legend. Hatteland Display Proprietary information. Not to be distributed to any third party without written permission.

# Technical Drawings - Accessories

Dimensions might be shown with or without decimals and indicated as mm [inches]. Tolerance on drawings is +/- 1mm. For accurate measurements, check relevant DWG file.

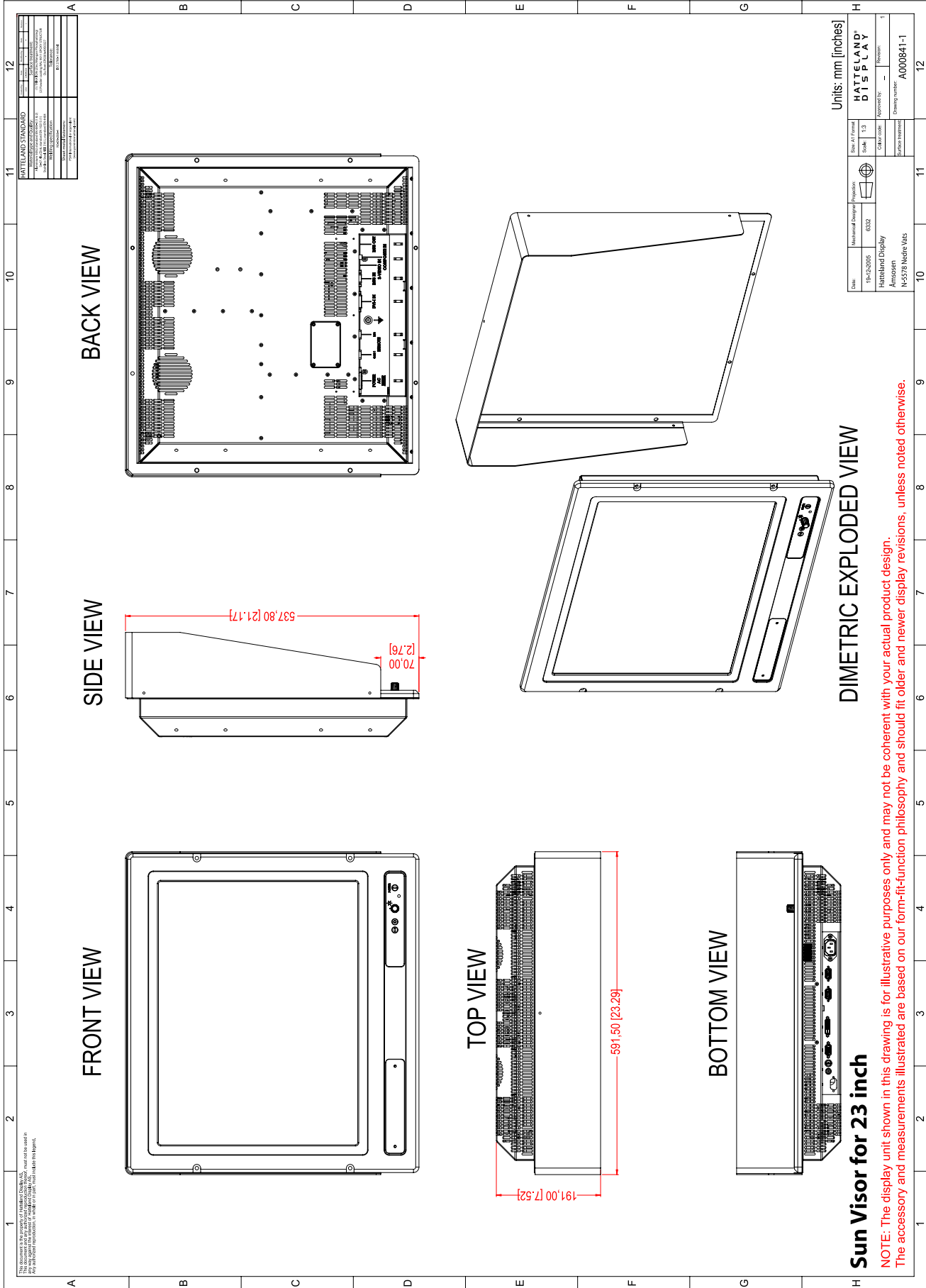

This document is the property of Hatteland Display AS. This document and any authorized reproduction thereof, must not be used in any way against the interest of Hatteland Display AS. Any authorized reproduction, in whole or in part, must include this legend. Hatteland Display Proprietary information. Not to be distributed to any third party without written permission.

# Technical Drawings - Accessories

Dimensions might be shown with or without decimals and indicated as mm [inches]. Tolerance on drawings is +/- .1mm. For accurate measurements, check relevant DWG file.

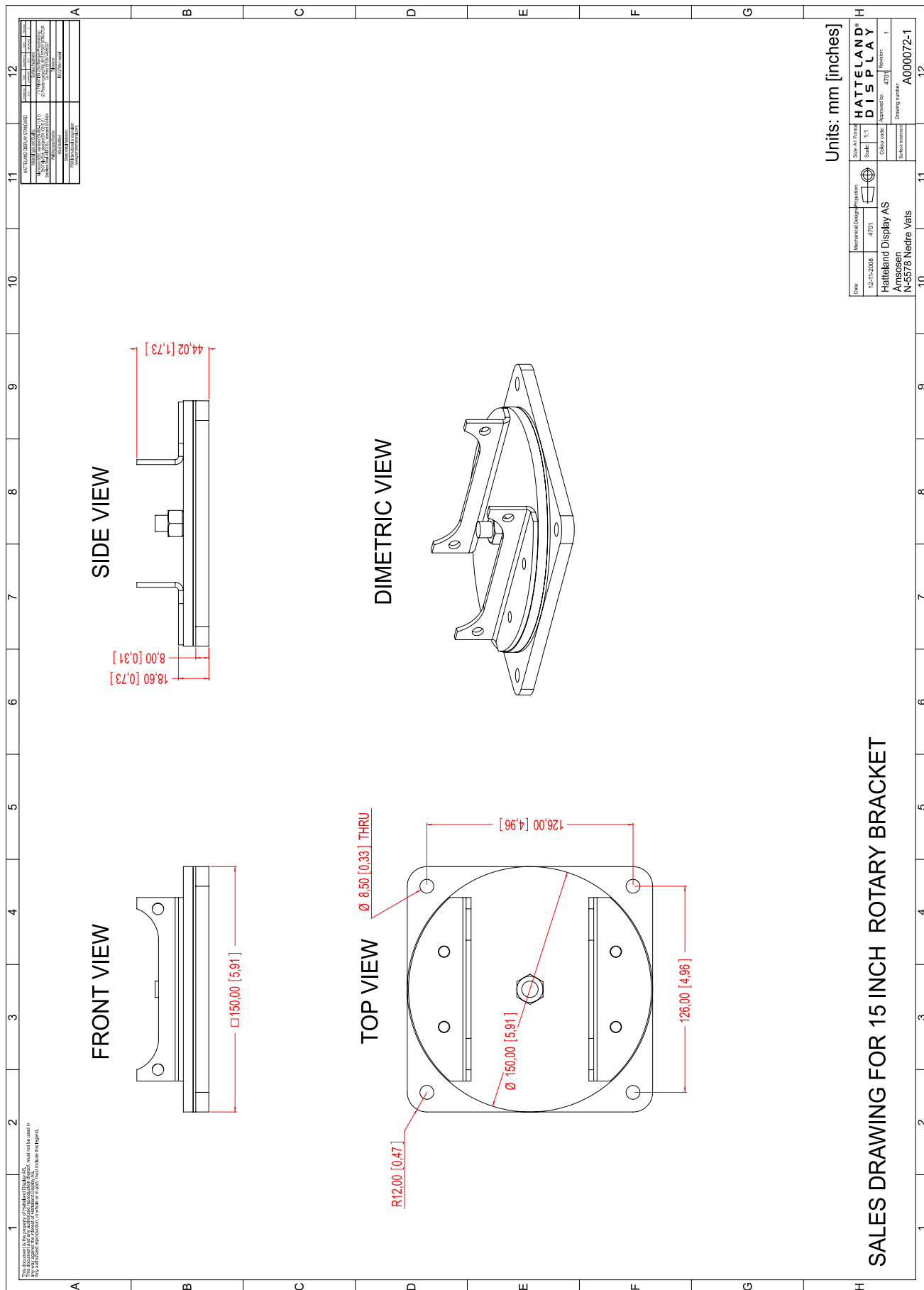

This document is the property of Hattelund Display AS. This document and any authorized reproduction thereof, must not be used in any way against the interest of Hattelund Display AS. Any authorized reproduction, in whole or in part, must include this legend. Hattelund Display Proprietary information. Not to be distributed to any third party without written permission.



# Technical Drawings - Accessories

Dimensions might be shown with or without decimals and indicated as mm [inches]. Tolerance on drawings is +/- 1mm. For accurate measurements, check relevant DWG file.

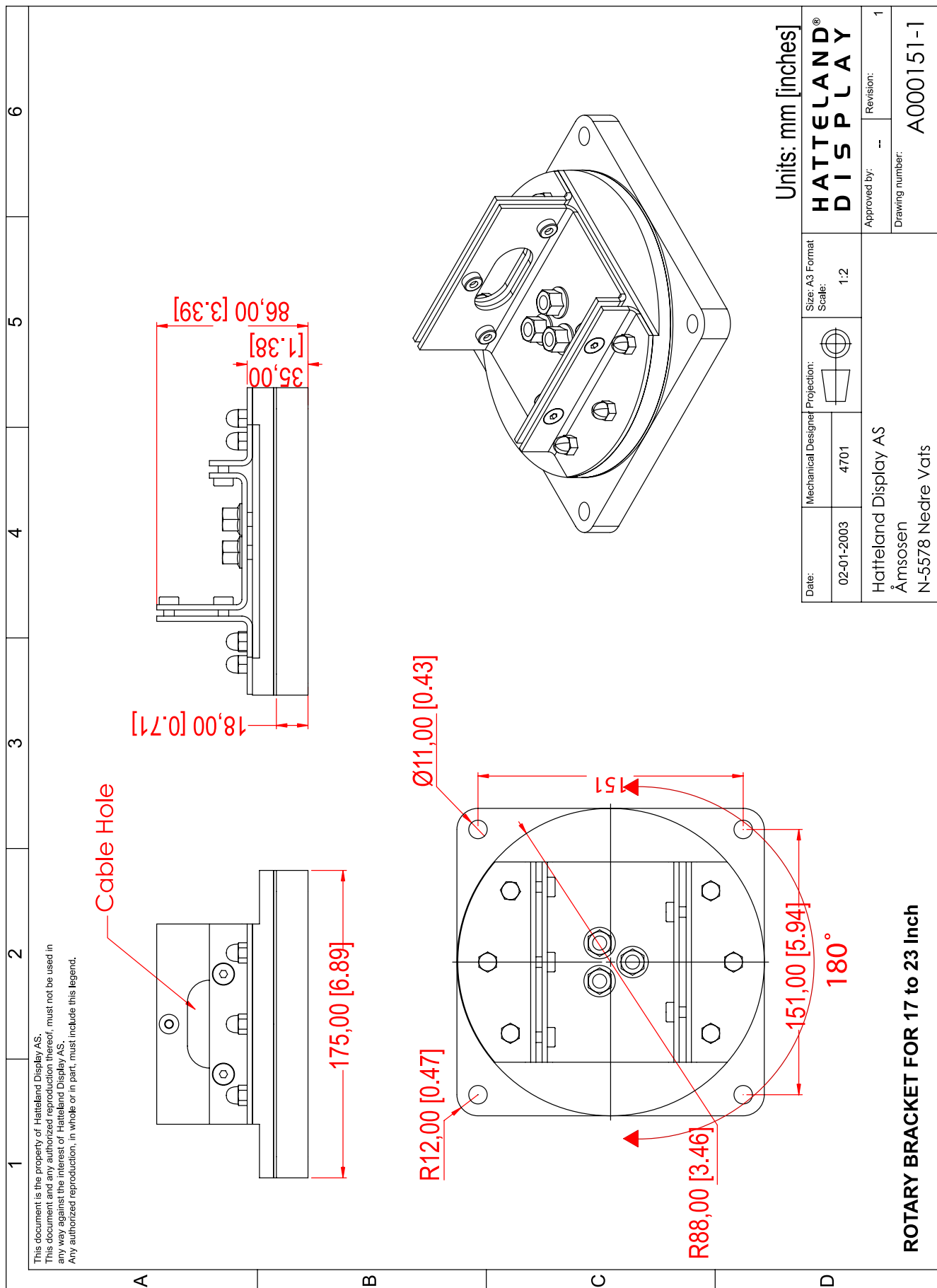

This document is the property of Hatteland Display AS. This document and any authorized reproduction thereof, must not be used in any way against the interest of Hatteland Display AS. Any authorized reproduction, in whole or in part, must include this legend. Hatteland Display Proprietary information. Not to be distributed to any third party without written permission.

Dimensions might be shown with or without decimals and indicated as mm [inches]. Tolerance on drawings is +/- 1mm. For accurate measurements, check relevant DWG file.

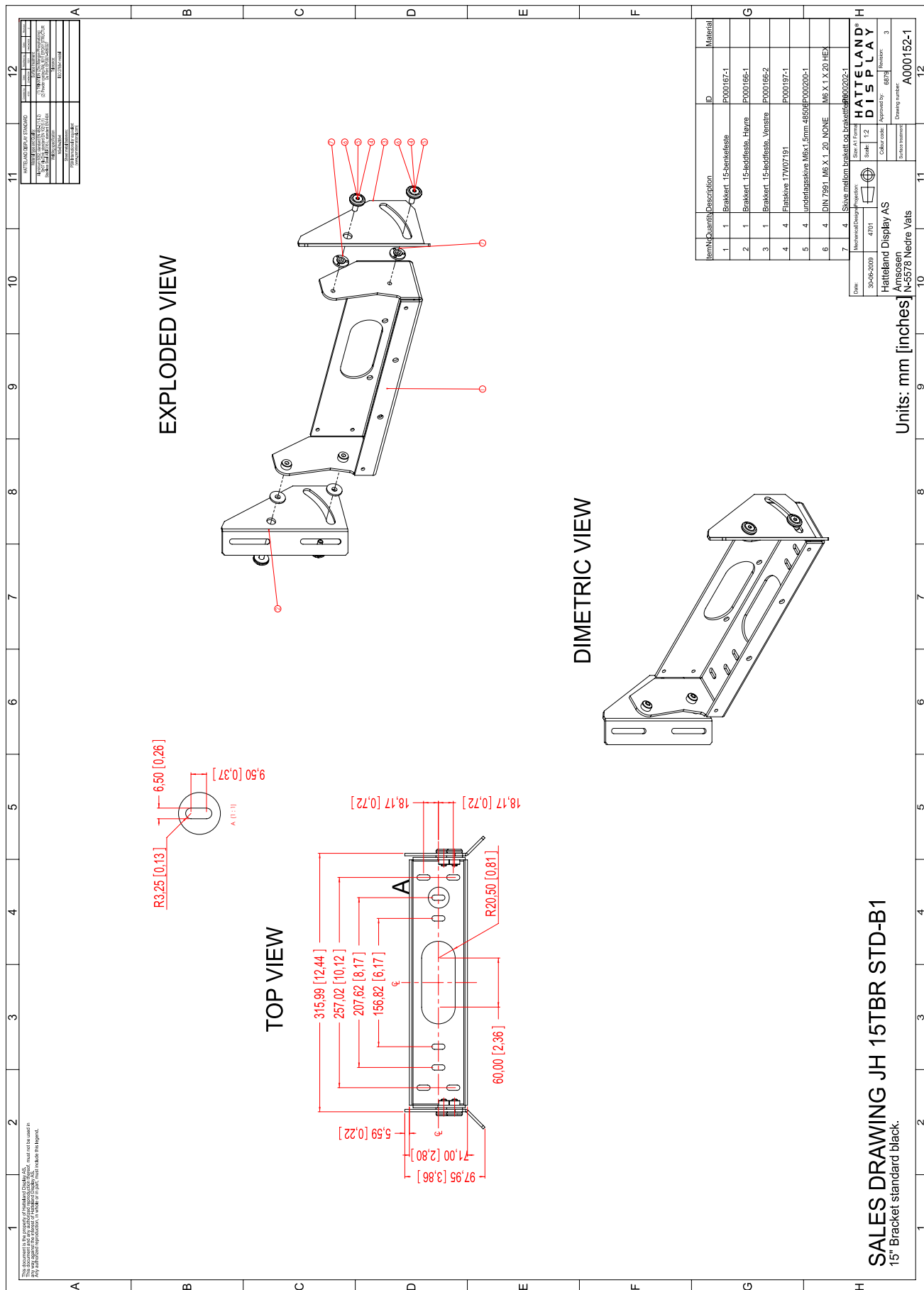

This document is the property of Hatteland Display AS. This document and any authorized reproduction thereof, must not be used in any way against the interest of Hatteland Display AS. Any authorized reproduction, in whole or in part, must include this legend. Hatteland Display Proprietary information. Not to be distributed to any third party without written permission.

# Technical Drawings - Accessories

Dimensions might be shown with or without decimals and indicated as mm [inches]. Tolerance on drawings is +/- 1mm. For accurate measurements, check relevant DWG file.

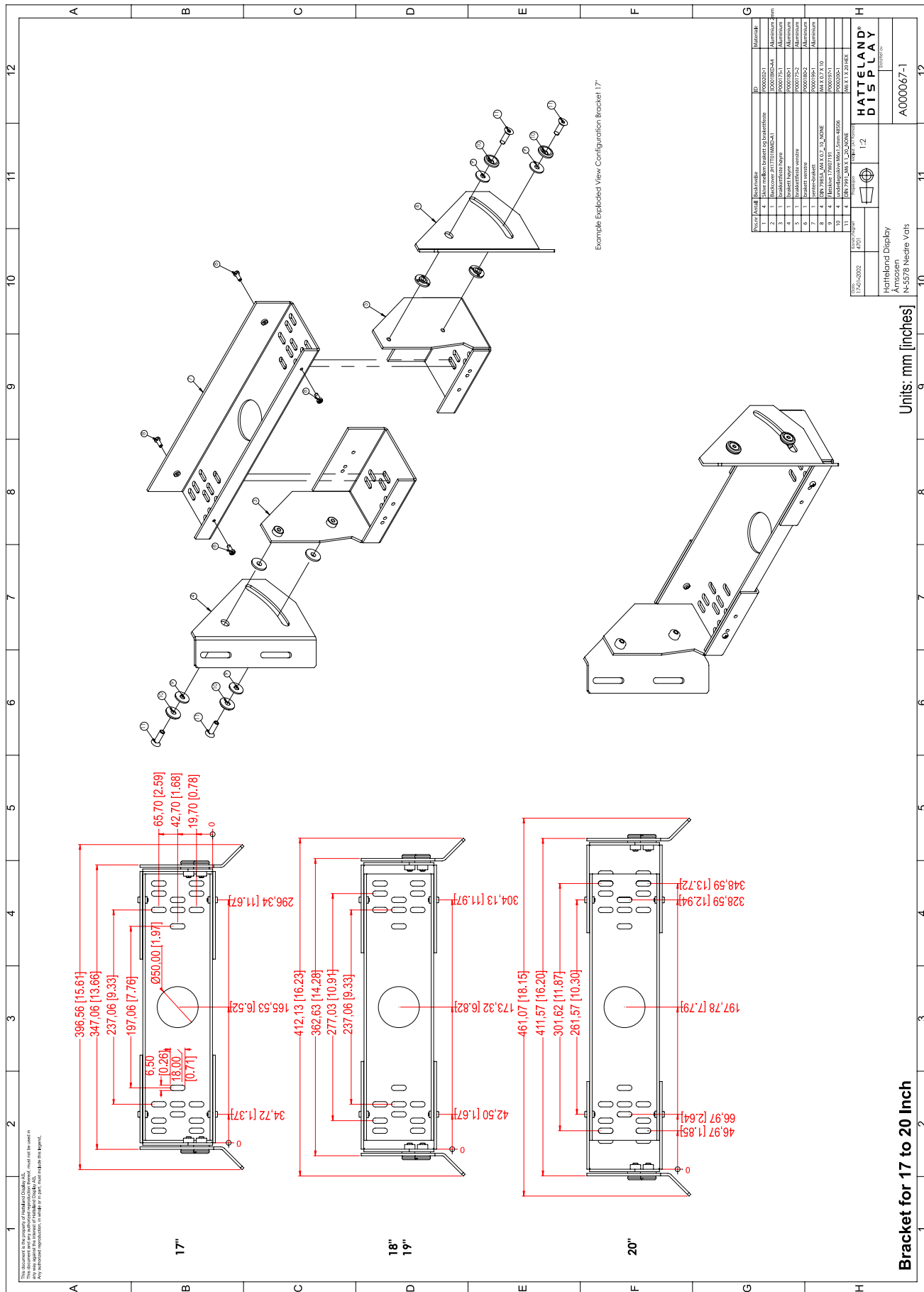

This document is the property of Hatteland Display AS. This document and any authorized reproduction thereof, must not be used in any way against the interest of Hatteland Display AS. Any authorized reproduction, in whole or in part, must include this legend. Hatteland Display Proprietary information. Not to be distributed to any third party without written permission.

# Technical Drawings - Accessories

Dimensions might be shown with or without decimals and indicated as mm [inches]. Tolerance on drawings is +/- 1mm. For accurate measurements, check relevant DWG file.

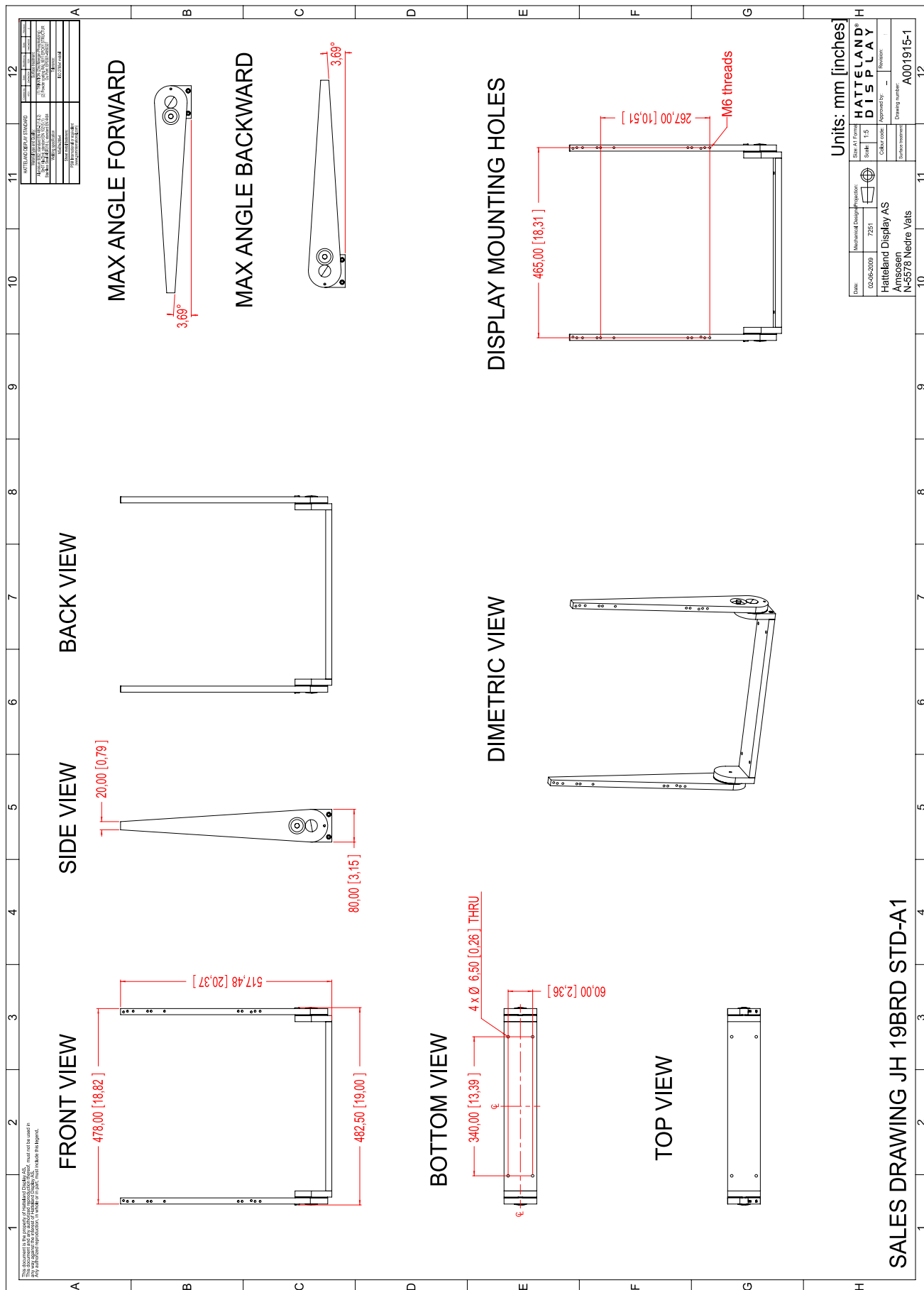

This document is the property of Hatteland Display AS. This document and any authorized reproduction thereof, must not be used in any way against the interest of Hatteland Display AS. Any authorized reproduction, in whole or in part, must include this legend. Hatteland Display Proprietary information. Not to be distributed to any third party without written permission.

Dimensions might be shown with or without decimals and indicated as mm [inches]. Tolerance on drawings is +/- 1mm. For accurate measurements, check relevant DWG file.

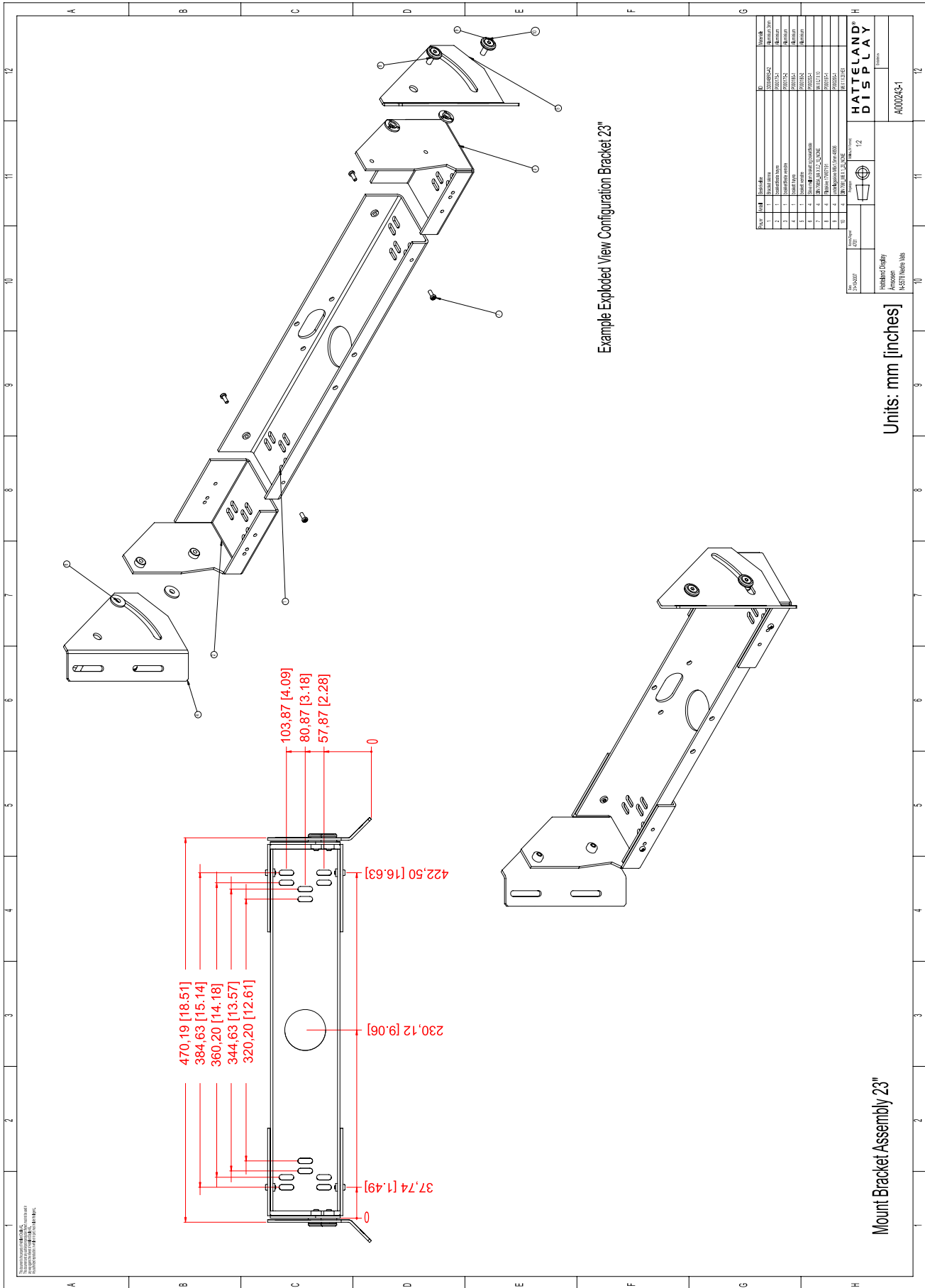

This document is the property of Hatteland Display AS. This document and any authorized reproduction thereof, must not be used in any way against the interest of Hatteland Display AS. Any authorized reproduction, in whole or in part, must include this legend. Hatteland Display Proprietary information. Not to be distributed to any third party without written permission.

# Technical Drawings - Accessories

Dimensions might be shown with or without decimals and indicated as mm [inches]. Tolerance on drawings is +/- .1mm. For accurate measurements, check relevant DWG file.

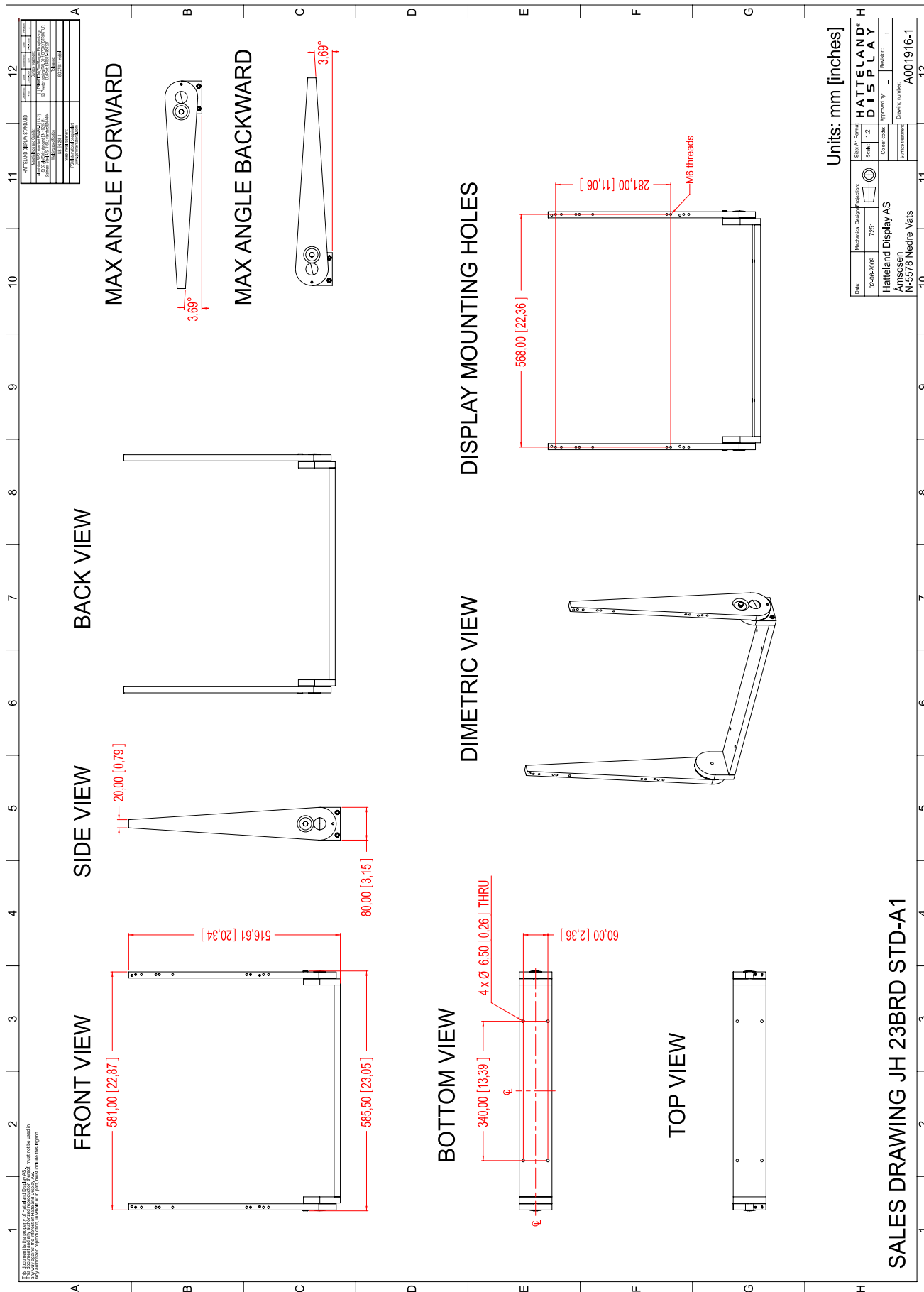

23" EN60945 Bracket

70

INB100036-3 (Rev 3)

This document is the property of Hatteland Display AS. This document and any authorized reproduction thereof, must not be used in any way against the interest of Hatteland Display AS. Any authorized reproduction, in whole or in part, must include this legend. Hatteland Display Proprietary information. Not to be distributed to any third party without written permission.

# Technical Drawings - Accessories

Dimensions might be shown with or without decimals and indicated as mm [inches]. Tolerance on drawings is +/- .1mm. For accurate measurements, check relevant DWG file.

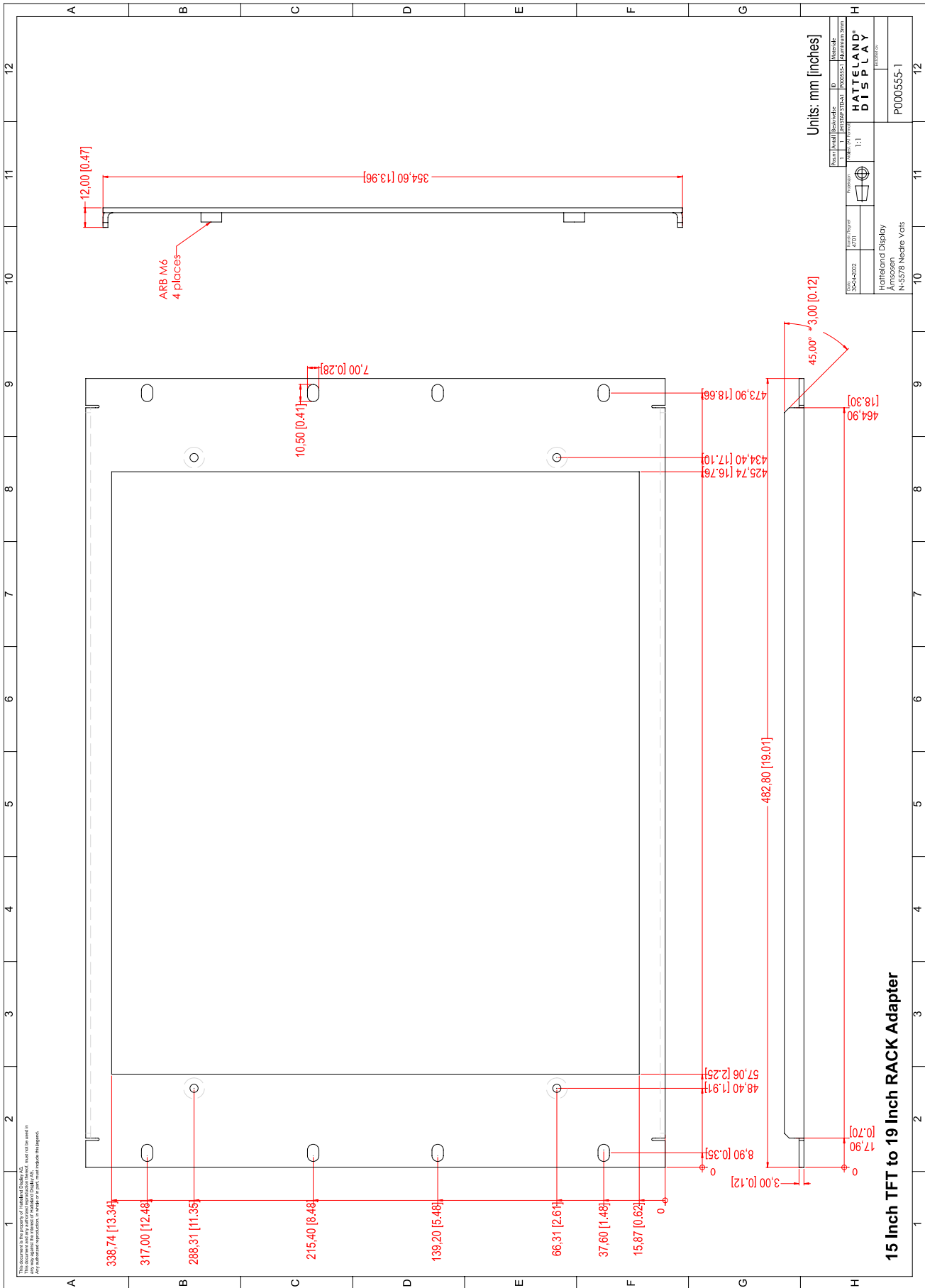

This document is the property of Hatteland Display AS. This document and any authorized reproduction thereof, must not be used in any way against the interest of Hatteland Display AS. Any authorized reproduction, in whole or in part, must include this legend. Hatteland Display Proprietary information. Not to be distributed without written permission.

# Technical Drawings - Accessories

Dimensions might be shown with or without decimals and indicated as mm [inches]. Tolerance on drawings is +/- .1mm. For accurate measurements, check relevant DWG file.

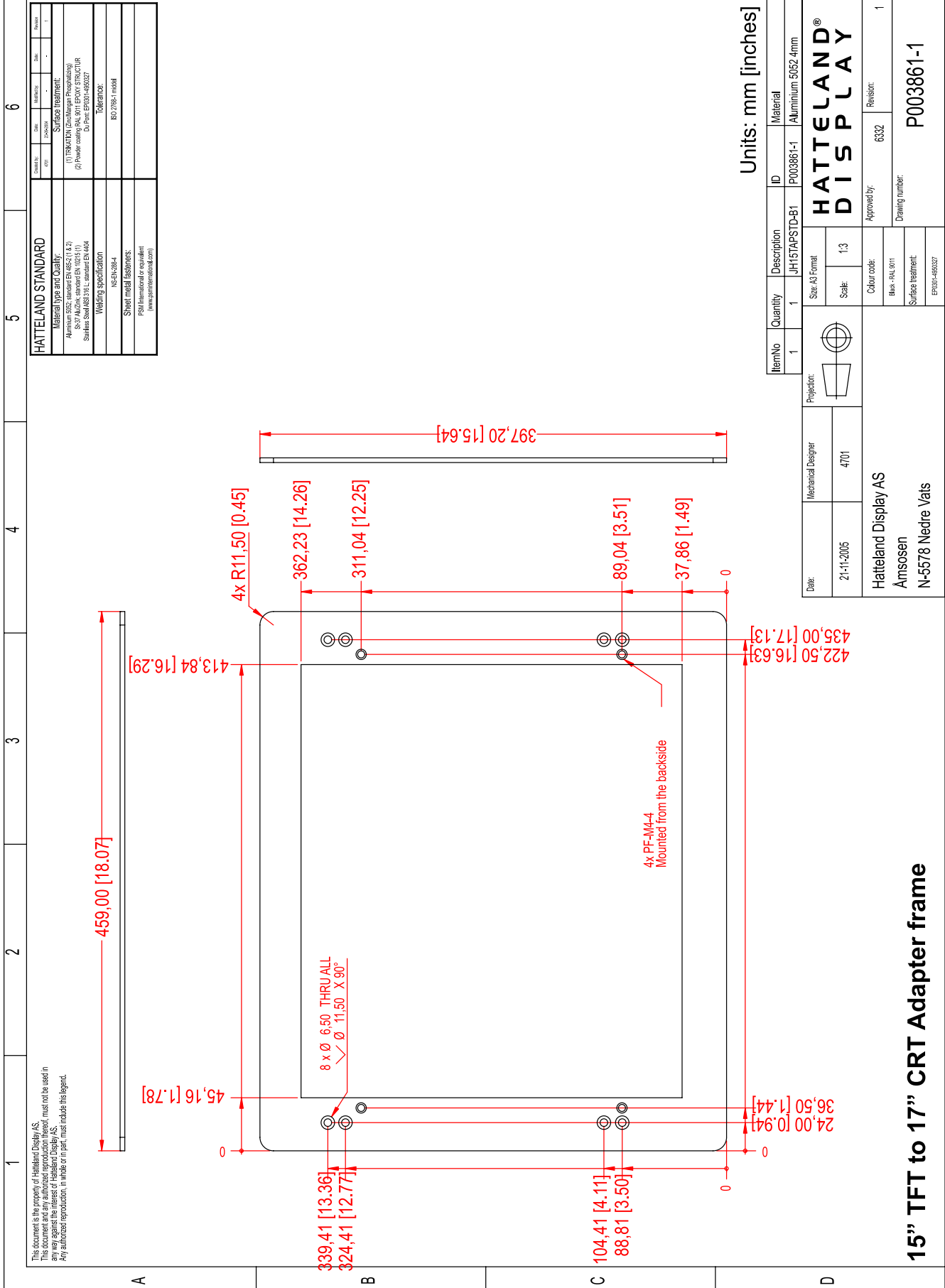

This document is the property of Hatteland Display AS. This document and any authorized reproduction thereof, must not be used in any way against the interest of Hatteland Display AS. Any authorized reproduction, in whole or in part, must include this legend. Hatteland Display Proprietary information. Not to be distributed to any third party without written permission.



# Technical Drawings - Accessories

Dimensions might be shown with or without decimals and indicated as mm [inches]. Tolerance on drawings is +/- 1mm. For accurate measurements, check relevant DWG file.

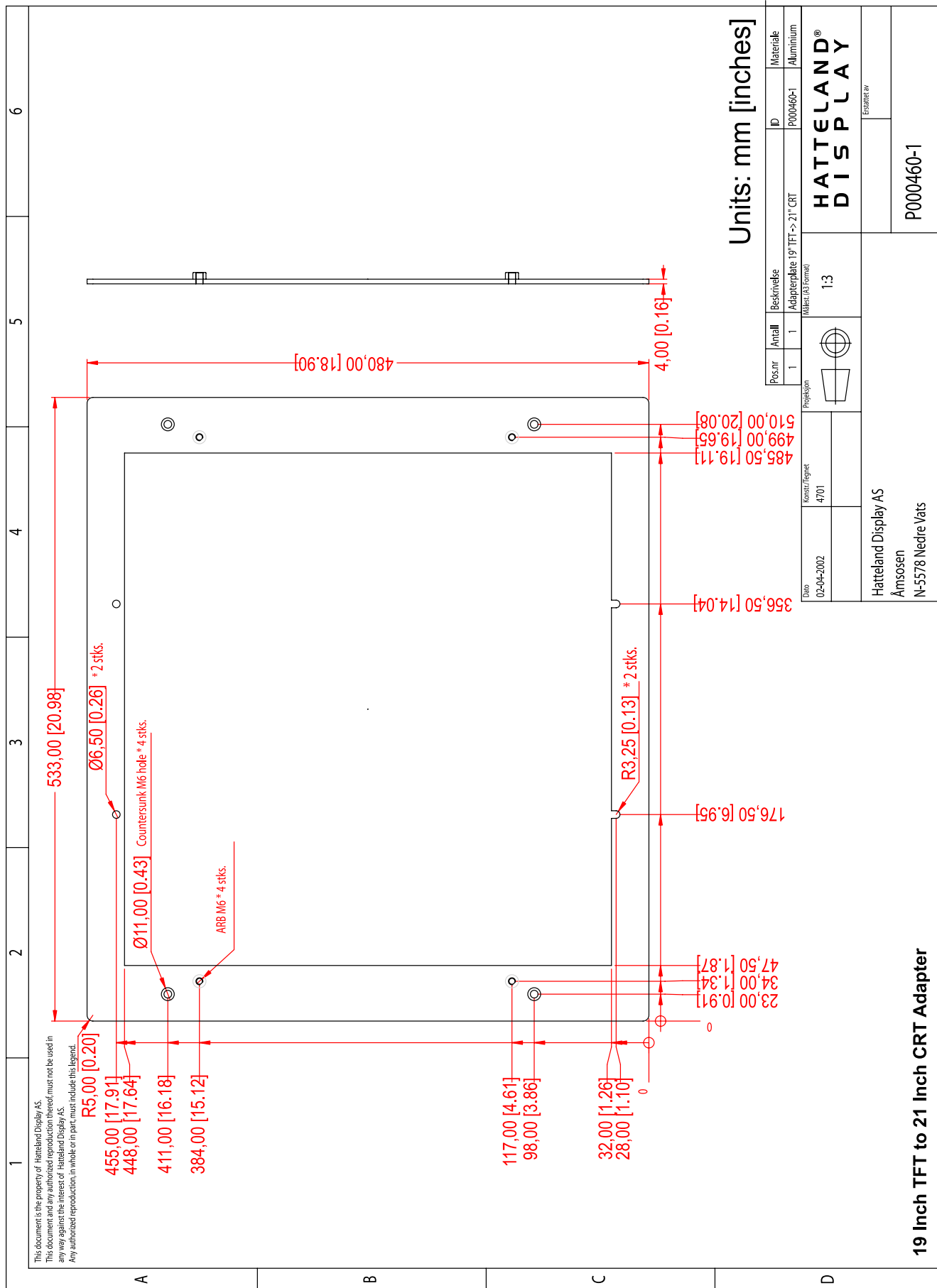

19" TFT to 21" CRT Adapter 73

INB100036-3 (Rev 3)

This document is the property of Hatteland Display AS. This document and any authorized reproduction thereof, must not be used in any way against the interest of Hatteland Display AS. Any authorized reproduction, in whole or in part, must include this legend. Hatteland Display Proprietary information. Not to be distributed to any third party without written permission.

Dimensions might be shown with or without decimals and indicated as mm [inches]. Tolerance on drawings is +/- 1mm. For accurate measurements, check relevant DWG file.

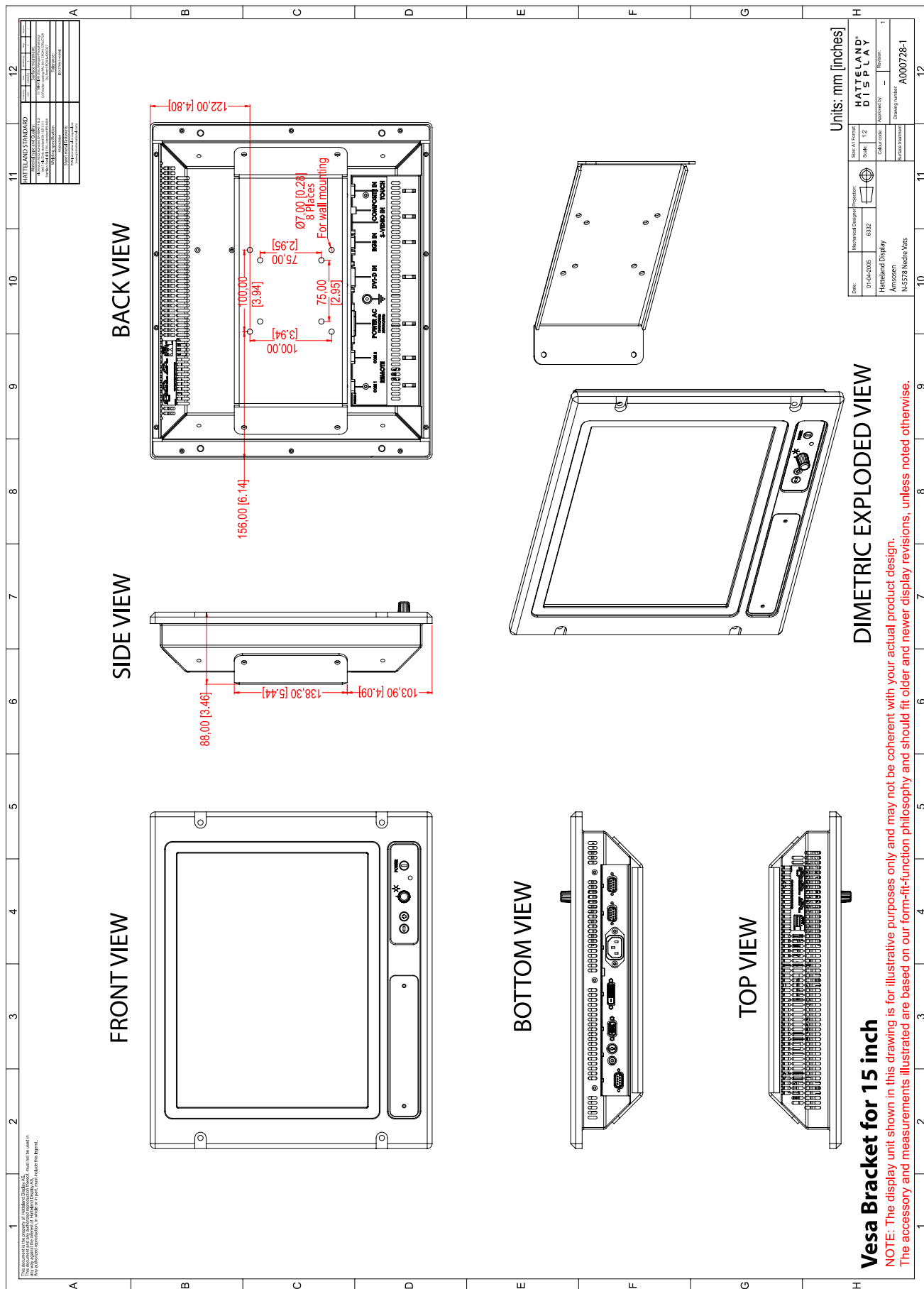

This document is the property of Hatteland Display AS. This document and any authorized reproduction thereof, must not be used in any way against the interest of Hatteland Display AS. Any authorized reproduction, in whole or in part, must include this legend. Hatteland Display Proprietary information. Not to be distributed to any third party without written permission.

# Technical Drawings - Accessories

Dimensions might be shown with or without decimals and indicated as mm [inches]. Tolerance on drawings is +/- 1mm. For accurate measurements, check relevant DWG file.

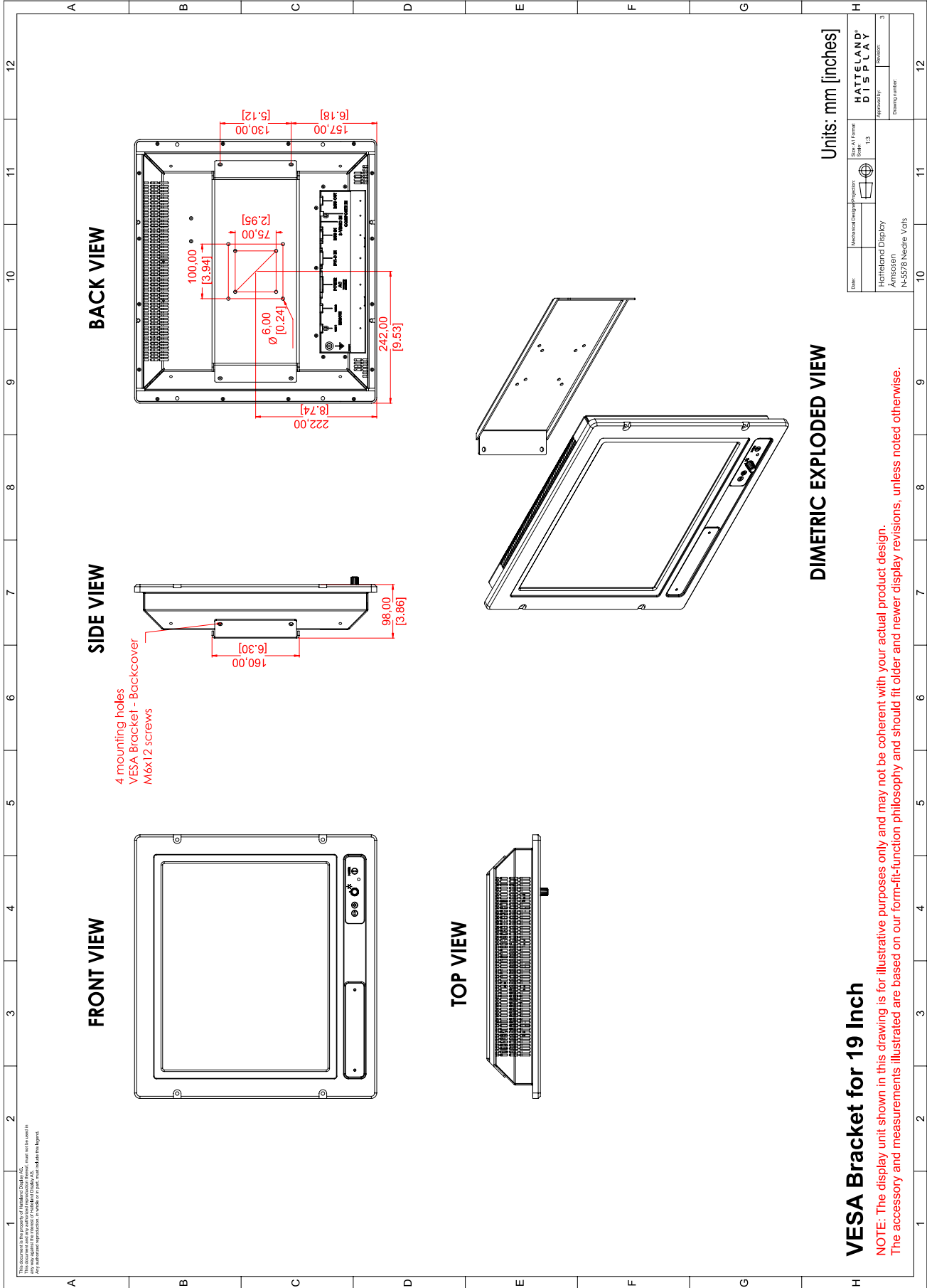

This document is the property of Hatteland Display AS. This document and any authorized reproduction thereof, must not be used in any way against the interest of Hatteland Display AS. Any authorized reproduction, in whole or in part, must include this legend. Hatteland Display Proprietary information. Not to be distributed to any third party without written permission.

VESA Bracket - 19"

75

INB100036-3 (Rev 3)

IND100132-45

Dimensions might be shown with or without decimals and indicated as mm [inches]. Tolerance on drawings is +/- 1mm. For accurate measurements, check relevant DWG file.

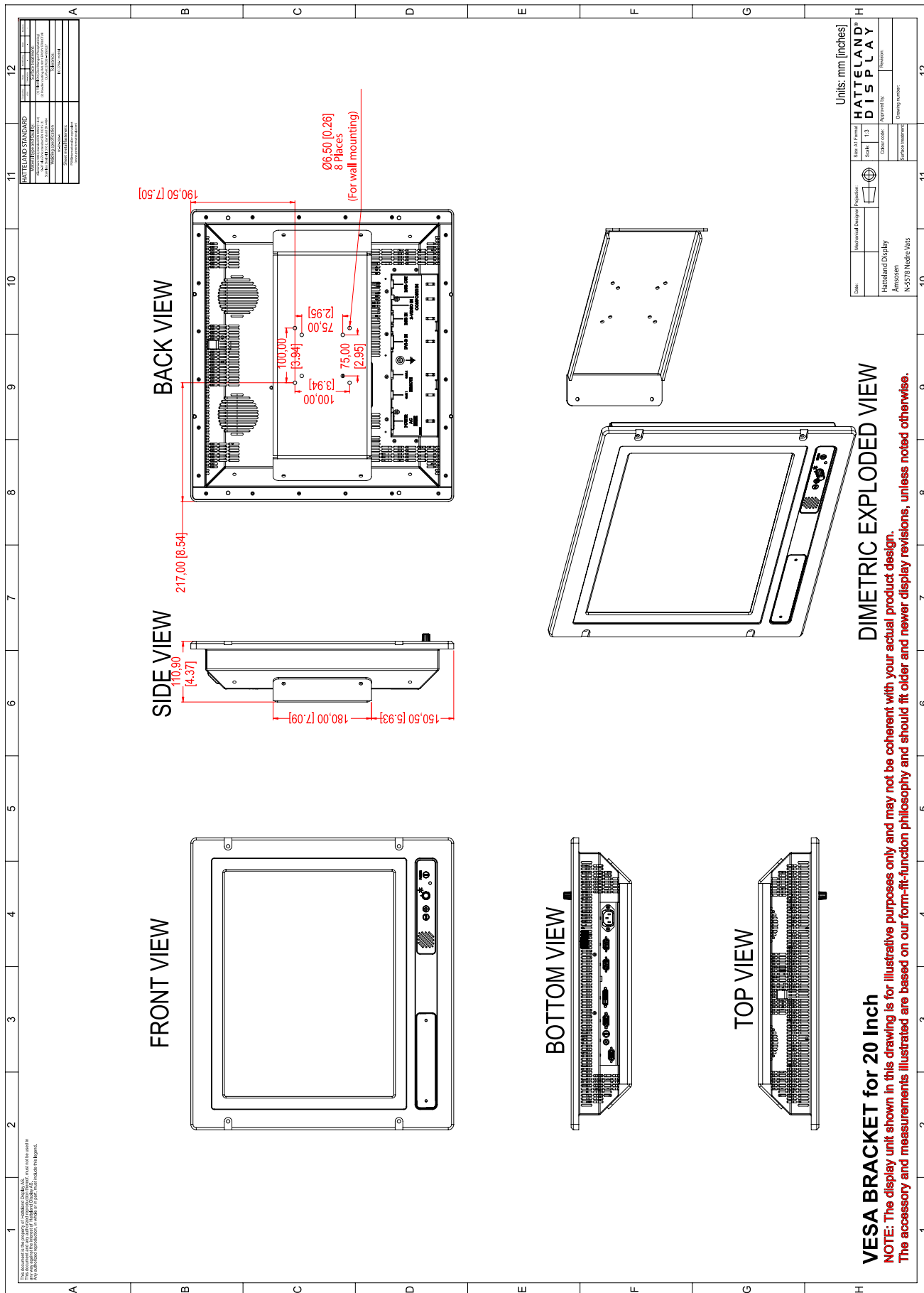

### VESA BRACKET for 20 Inch

**NOTE:** The display unit shown in this drawing is for illustrative purposes only and may not be coherent with your actual product design. The accessory and measurements illustrated are based on our form-fit-function philosophy and should fit older and newer display revisions, unless noted otherwise.

### DIMETRIC EXPLODED VIEW

This document is the property of Hatteland Display AS. This document and any authorized reproduction thereof, must not be used in any way against the interest of Hatteland Display AS. Any authorized reproduction, in whole or in part, must include this legend. Hatteland Display Proprietary information. Not to be distributed to any third party without written permission.

# Technical Drawings - Accessories

Dimensions might be shown with or without decimals and indicated as mm [inches]. Tolerance on drawings is +/- 1mm. For accurate measurements, check relevant DWG file.

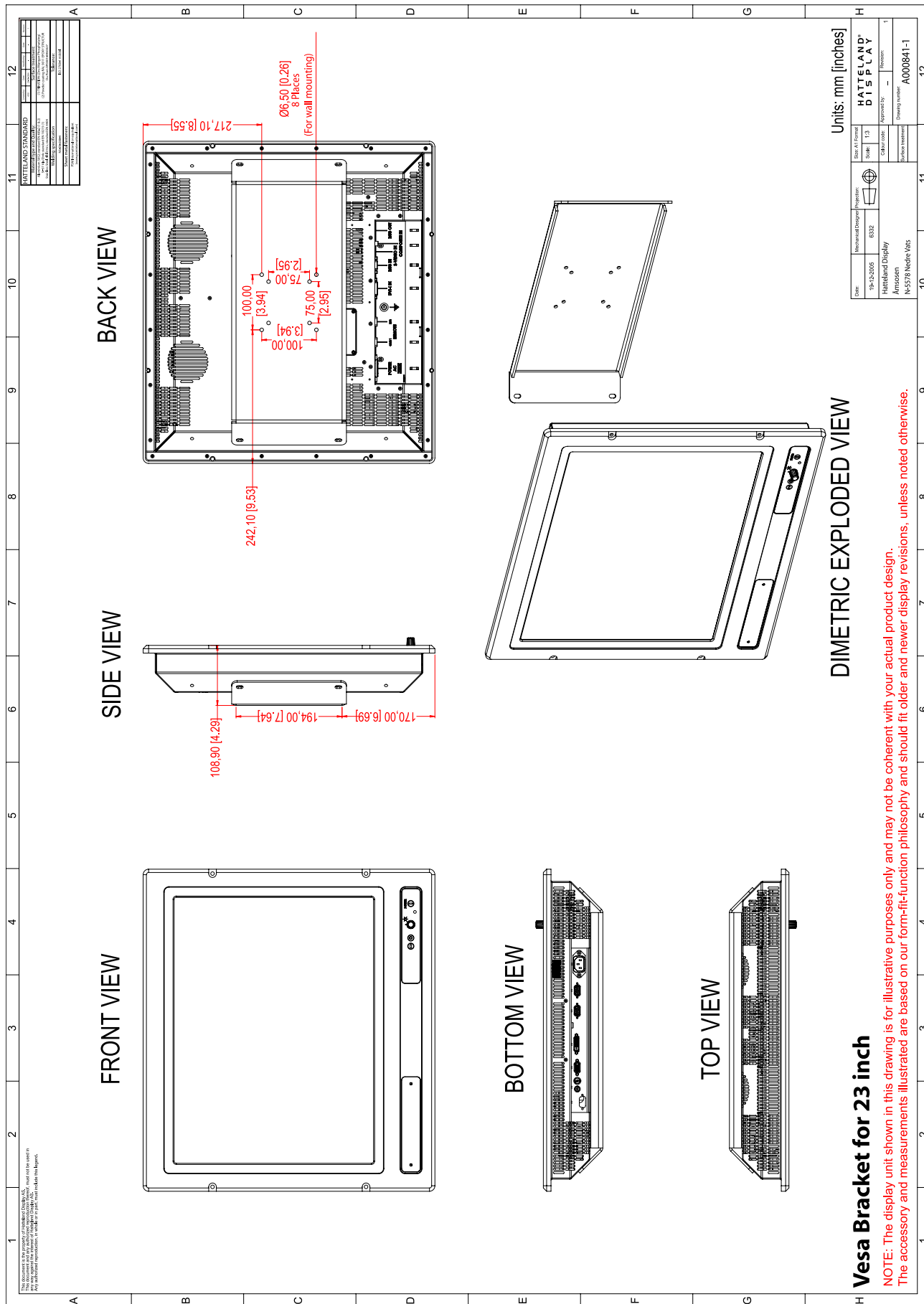

This document is the property of Hatteland Display AS. This document and any authorized reproduction thereof, must not be used in any way against the interest of Hatteland Display AS. Any authorized reproduction, in whole or in part, must include this legend. Hatteland Display Proprietary information. Not to be distributed to any third party without written permission.

# Technical Drawings - Accessories

Dimensions might be shown with or without decimals and indicated as mm [inches]. Tolerance on drawings is +/- .1mm. For accurate measurements, check relevant DWG file.

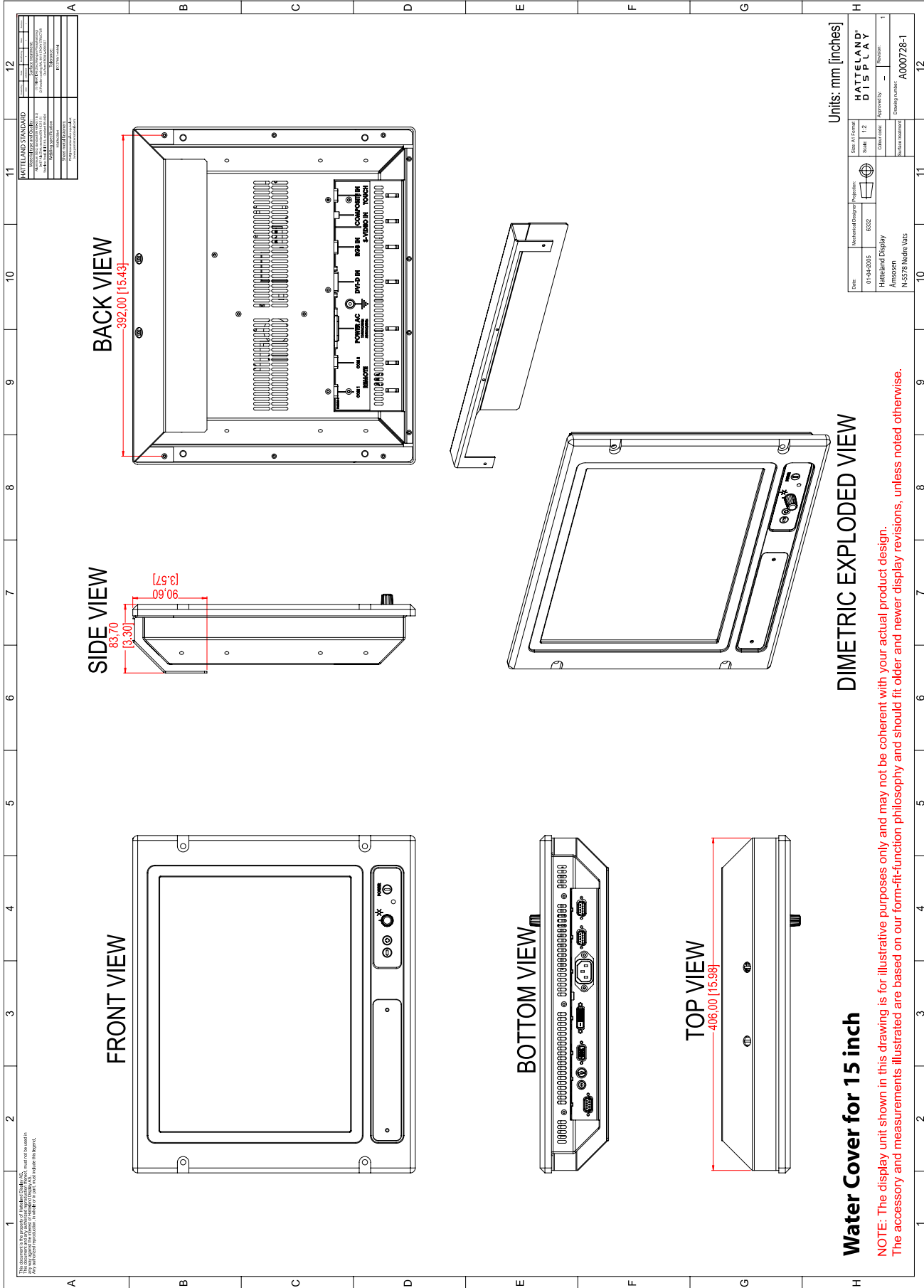

**NOTE:** The display unit shown in this drawing is for illustrative purposes only and may not be coherent with your actual product design. The accessory and measurements illustrated are based on our form-fit-function philosophy and should fit older and newer display revisions, unless noted otherwise.

This document is the property of Hatteland Display AS. This document and any authorized reproduction thereof, must not be used in any way against the interest of Hatteland Display AS. Any authorized reproduction, in whole or in part, must include this legend. Hatteland Display Proprietary information. Not to be distributed to any third party without written permission.

# Technical Drawings - Accessories

Dimensions might be shown with or without decimals and indicated as mm [inches]. Tolerance on drawings is +/- .1mm. For accurate measurements, check relevant DWG file.

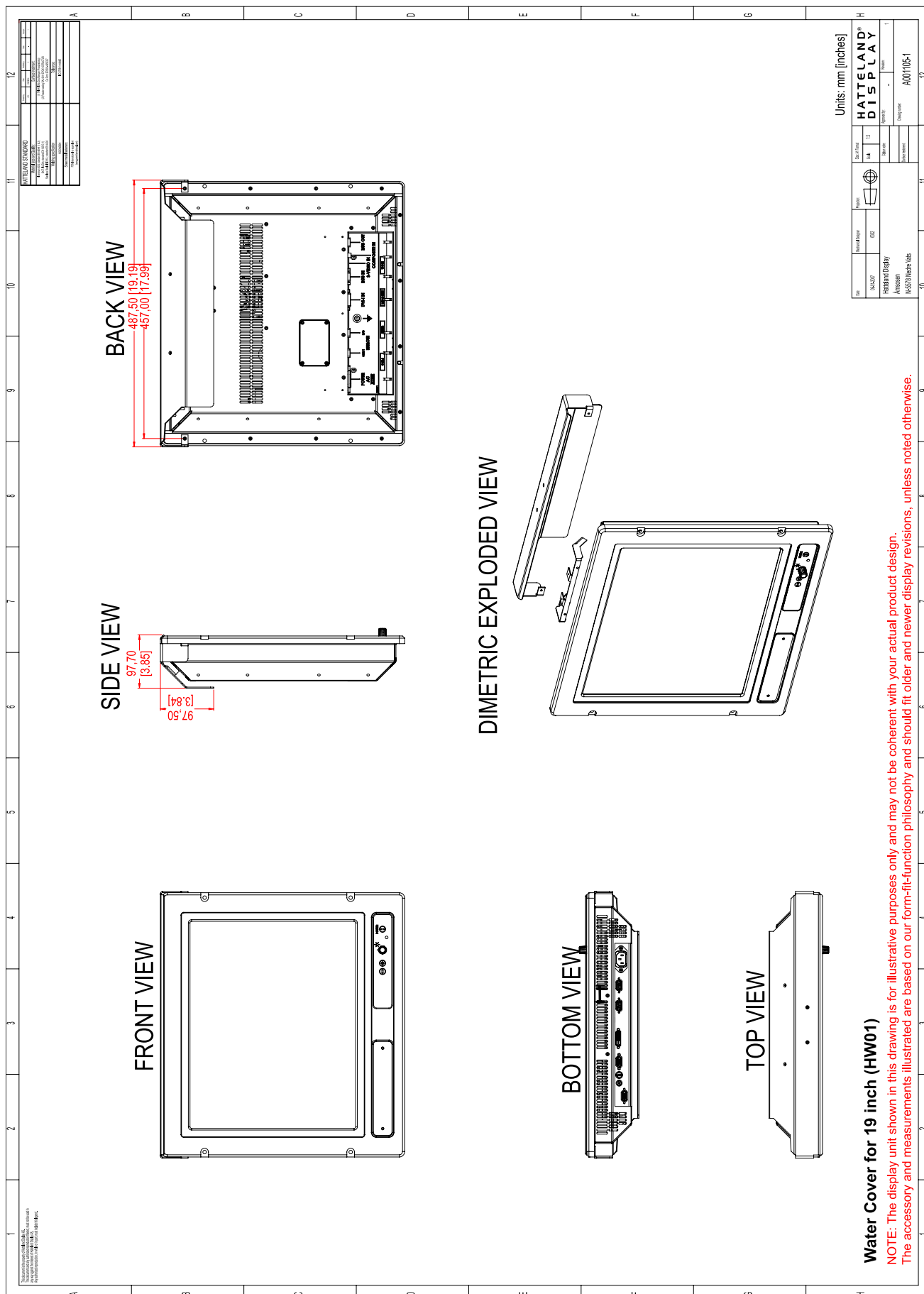

## Water Cover for 19 inch (HW01)

**NOTE:** The display unit shown in this drawing is for illustrative purposes only and may not be coherent with your actual product design. The accessory and measurements illustrated are based on our form-fit-function philosophy and should fit older and newer display revisions, unless noted otherwise.

This document is the property of Hatteland Display AS. This document and any authorized reproduction thereof, must not be used in any way against the interest of Hatteland Display AS. Any authorized reproduction, in whole or in part, must include this legend. Hatteland Display Proprietary information. Not to be distributed to any third party without written permission.

# Technical Drawings - Accessories

Dimensions might be shown with or without decimals and indicated as mm [inches]. Tolerance on drawings is +/- .1mm. For accurate measurements, check relevant DWG file.

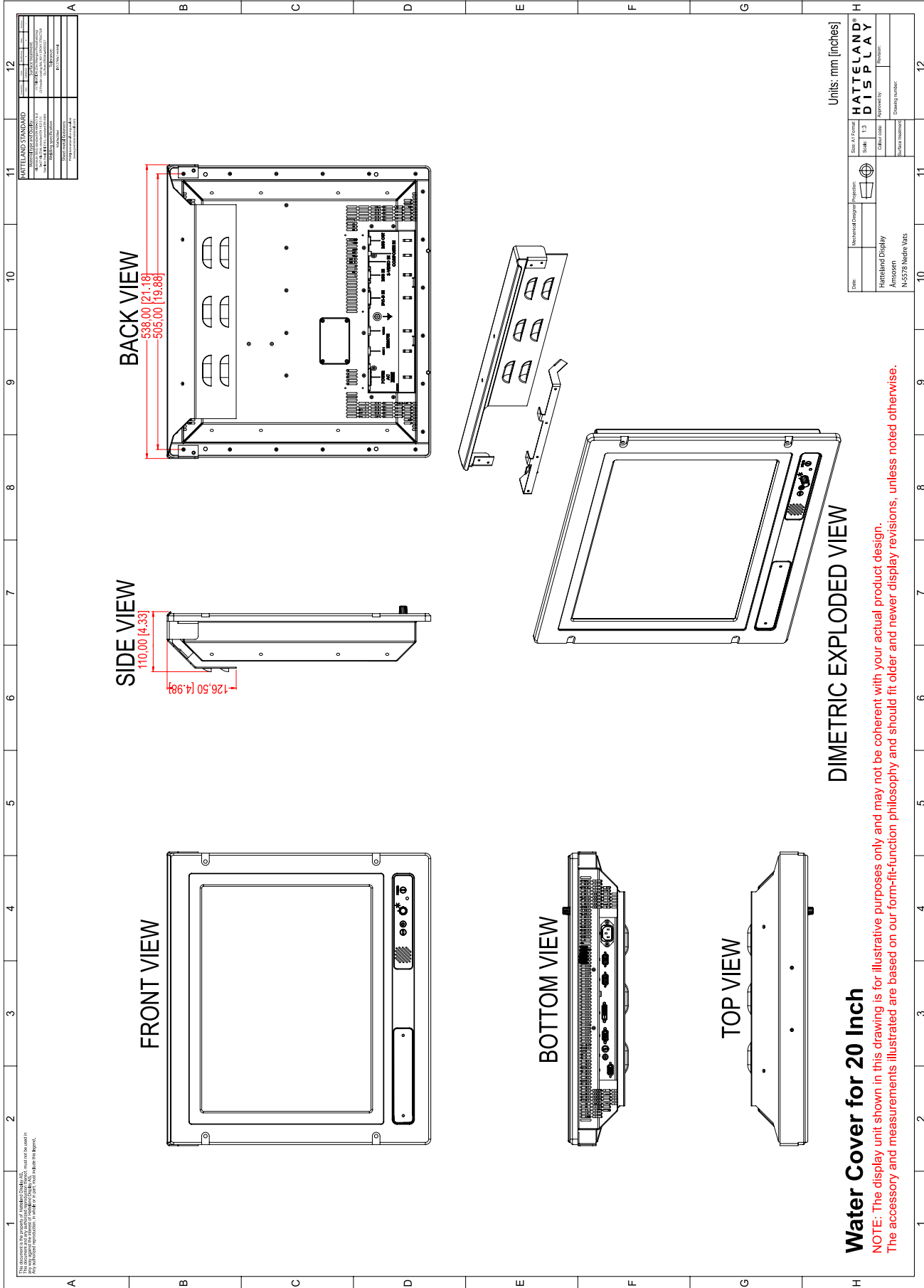

This document is the property of Hatteland Display AS. This document and any authorized reproduction thereof, must not be used in any way against the interest of Hatteland Display AS. Any authorized reproduction, in whole or in part, must include this legend. Hatteland Display Proprietary information. Not to be distributed to any third party without written permission.



# Technical Drawings - Accessories

Dimensions might be shown with or without decimals and indicated as mm [inches]. Tolerance on drawings is +/- .1mm. For accurate measurements, check relevant DWG file.

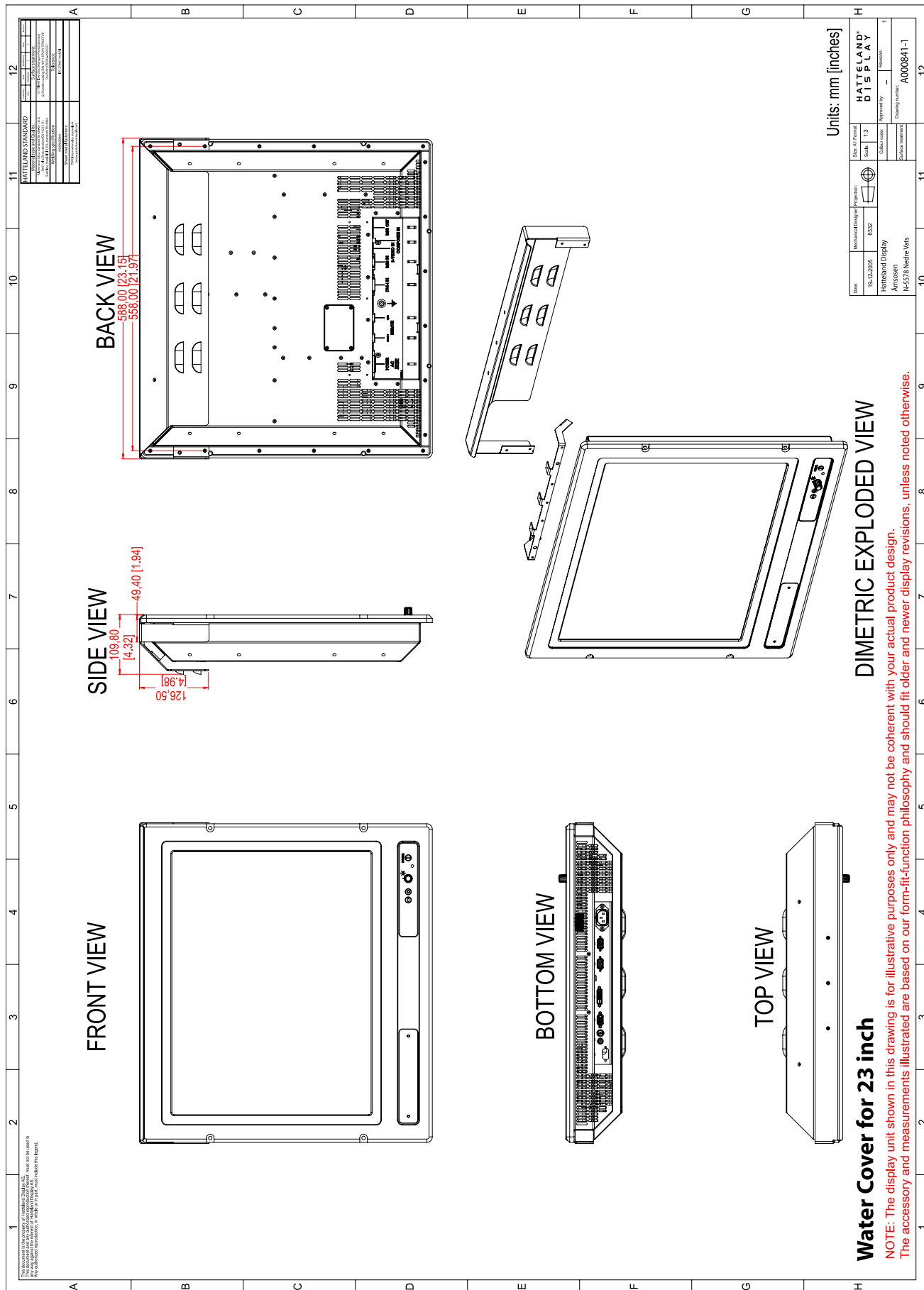

This document is the property of Hatteland Display AS. This document and any authorized reproduction thereof, must not be used in any way against the interest of Hatteland Display AS. Any authorized reproduction, in whole or in part, must include this legend. Hatteland Display Proprietary information. Not to be distributed to any third party without written permission.

This page left intentionally blank



# Appendixes

# Pin Assignments - Common Connectors

**Note:** Not all connectors may be available on your specific product. This depends on the amount of additional hardware installed from factory, or customized solutions. These pin assignments are for the common connectors used. **Connectors are seen from users Point Of View (POV).**

## Pin Assignments - 24P DVI-I

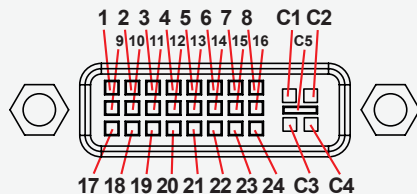

Pin 01	T.M.D.S. Data2 - (Digital - RED link 1)
Pin 02	T.M.D.S. Data2 + (Digital + RED link 1)
Pin 03	T.M.D.S. Data2/4 Shield
Pin 04	T.M.D.S. Data4 - (Digital - GREEN link 2)
Pin 05	T.M.D.S. Data4 + (Digital + GREEN link 2)
Pin 06	DDC Clock
Pin 07	DDC Data
Pin 08	Analog Vertical Sync (DVI-I only)
Pin 09	T.M.D.S. Data1 - (Digital - GREEN link 1)
Pin 10	T.M.D.S. Data1 + (Digital + GREEN link 1)
Pin 11	T.M.D.S. Data1/3 Shield
Pin 12	T.M.D.S. Data3 - (Digital - BLUE link 2)
Pin 13	T.M.D.S. Data3 + (Digital + BLUE link 2)
Pin 14	+5V Power (for standby mode)
Pin 15	Ground (for +5V and analog sync)
Pin 16	Hot Plug Detect
Pin 17	T.M.D.S. Data0 - (Digital - BLUE link 1) and digital sync.
Pin 18	T.M.D.S. Data0 + (Digital + BLUE link 1) and digital sync.
Pin 19	T.M.D.S. Data0/5 Shield
Pin 20	T.M.D.S. Data5 - (Digital - RED link 2)
Pin 21	T.M.D.S. Data5 + (Digital - RED link 2)
Pin 22	T.M.D.S. Clock Shield
Pin 23	T.M.D.S. Clock + (Digital clock + (Links 1 and 2))
Pin 24	T.M.D.S. Clock - (Digital clock - (Links 1 and 2))
Pin C1	Analog RED
Pin C2	Analog GREEN
Pin C3	Analog BLUE
Pin C4	Analog Horizontal Sync.
Pin C5	Analog Ground (return for RGB signals)

DDC = Display Data Channel /// T.M.D.S = Transition Minimized Differential Signal /// PIN C1,C2,C3,C4 = Only present on DVI-I connectors.  
NOTE: Connector shows a DUAL LINK design, but some units may not support it. Only products with 1920x1200 or more in resolution require / support DUAL LINK.

## Pin Assignments - 15P HD RGB VGA

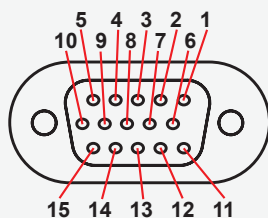

Pin 01	Red, analog
Pin 02	Green, analog
Pin 03	Blue, analog
Pin 04	Reserved for monitor ID bit 2 (grounded)
Pin 05	Digital ground
Pin 06	Analog ground red
Pin 07	Analog ground green
Pin 08	Analog ground blue
Pin 09	+5V power supply for DDC (optional)
Pin 10	Digital ground
Pin 11	Reserved for monitor ID bit 0 (grounded)
Pin 12	DDC serial data
Pin 13	Horizontal sync or composite sync, input
Pin 14	Vertical sync, input
Pin 15	DDC serial clock

## Pin Assignments - USB TYPE B

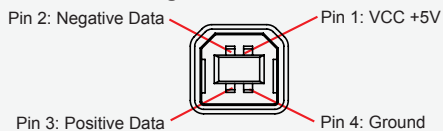

# Pin Assignments - Multifunction Cable Outputs

Connectors that are commonly available on the HATTELAND® Multifunction Cable or customized cable.  
 Connectors are seen from users Point Of View (POV).

## Pin Assignments - 9P Serial COM RS232

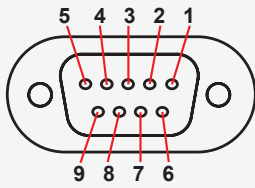

Pin 01 - CTRL(+)	Buzzer Control (+) (+12V input for driving the buzzer)
Pin 02 - TX	Transmit Data
Pin 03 - RX	Receive Data
Pin 04 - DTR	Data Terminal Ready
Pin 05 - GND	Ground
Pin 06 - DSR	Data Set Ready
Pin 07 - RTS	Request To Send
Pin 08 - CTS	Clear To Send
Pin 09 - CTRL (-)	Buzzer Control (-) (Pull low to activate buzzer)

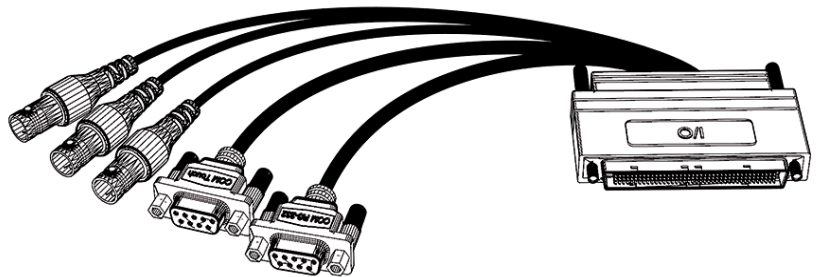

## Pin Assignments - 5P S-VHS/S-VIDEO

Pin 4: C - Color (chrominance)      Pin 3: Y - Intensity (luminance)



## Pin Assignments - RCA & BNC 1P COMP. VIDEO



## Basic Trouble-shooting

### GENERAL ISSUES FOR TFT PANEL BASED PRODUCTS

Note: Applies for a range of various products. This is only suitable for general guidance.

#### **NO PICTURE / LED BEHAVIOUR:**

If there is no light at all in the LED at the FRONT, check power cables. If the LED in front is green then check if the brightness knob is turned to the right (max brightness). If still no picture, check if there is a VGA signal on the External VGA connector. If you have a picture on the external VGA connector please look in BIOS documentation/chapter for correct display settings in BIOS. Lack of image is most likely to be caused by incorrect connection, lack of power, or wrong BIOS settings.

#### **SCROLLING / UNSTABLE IMAGE:**

Signal cable may not be completely connected to computer or TFT display. Check the pin assignments and signal timings of the display and your video card with respect to recommended timing and pin assignments. Make sure that the video card is compatible and that it is properly seated / installed on the computer.

#### **DISPLAY AREA IS NOT CENTERED / SIZED CORRECTLY**

Make sure that a supported video mode has been selected on the display, or on the video card / system. If it is impossible to position the image correctly, i.e. the image adjustment controls will not move the image far enough, then test it again using another graphics card for the PC system. This situation may occur with a custom graphics card that is not close to standard timings or if something is in the graphics line that may be affecting the signal, such as a signal splitter (please note that normally a signal splitter will not have any adverse effect). If it is impossible to change to the correct resolution/color depth, check if you have the right VGA driver installed in your system.

#### **IMAGE APPEARANCE:**

A faulty TFT panel can have black lines, pixel errors, failed sections, flickering or flashing image. Incorrect graphics card refresh rate, resolution or interlaced mode will probably cause the image to be the wrong size, it may scroll, flicker badly or possibly even no image is present. Sparkling on the display may be a faulty TFT panel signal cable, and it needs service attention.

RGB Signal Only: Horizontal interference can usually be corrected by adjusting the PHASE (OSD menu). Vertical interference can usually be corrected by adjusting the FREQUENCY (OSD menu).

#### **DEW CONDENSATION BEHIND GLASS:**

Note that this problem will not occur on bonded products. For non-bonded products, do the following: Power on the TFT product and set brightness to 100%. Turn off any automatic screensavers on PC or similar. During minutes the dew will be gone. To speed up the process, use a fan heater for a reasonable time. Do not overheat the TFT product.

### GENERAL ISSUES FOR COMPUTER BASED PRODUCTS

Note: Applies for a range of various products. This is only meant as a general guide.

#### **CD-ROM FAILURE OR READ/DETECTION PROBLEMS:**

If the product are operated/located in a area with extreme condensation, the CD/DVD drive may not work correctly due to condensation on the read head. Keep the product on for a while until it's reached normal operating temperature, and retry accessing discs. Otherwise, consider using USB memory sticks or alternative storage devices.

#### **NO CD-ROM AVAILABLE ON YOUR PRODUCT FOR INSTALLING DRIVERS/SOFTWARE:**

Please use USB memory sticks, USB Floppy drive, USB CD-Rom Drive or alternative storage devices to transfer/install software on CD-ROM-less units.

# HATTELAND® DISPLAY

## Declaration of Conformity

We, manufacturer

**Hatteland Display AS**  
Åmsosen, N-5578 Nedre Vats, Norway

declare under our sole responsibility that the  
JH MMD, JH MMC, JH STD, JH MIL, HM NMD  
HM MIL, HM CMD, HT STD, HD MMD & HT MMC  
product ranges is in conformity with the following  
standards in accordance with the EMC Directive.

Low Voltage Directive 2006/95/EC  
EN 60950

EMC Directive 2004/108/EC  
EN 55022 Class A  
EN 55024

Signature:.....  
Frode Grindheim  
Vice President Product Management  
Nedre Vats, Norway

Signature:.....  
Arne Kristiansen  
Site Manager - Test & Commission Division  
Oslo, Norway

Date: 19 Mar 2009



## Return Of Goods Information

### **Return of goods:** (Applies not to warranty/normal service/repair of products)

Hatteland Display referenced as "manufacturer" in this document.

Before returning goods, please contact your system supplier before sending anything directly to manufacturer. When you return products after loan, test, evaluation or products subject for credit, you must ensure that all accessories received from our warehouse is returned. This applies to cables, powermodules and additional equipment except screws or similar, user manual, datasheets or other written paper documents. Furthermore, the product must not have any minor / medium or severe scratches, chemical spills or similar on the backcover, front frame or glass.

This is needed to credit the invoice 100%. Missing parts will not be subject for credit, and you will not get total credit for returned product. You will either be charged separately or the amount is withdrawn from the credit. If you decide to ship the missing items on the after hand, you will get 100% credit for that particular invoice or items received at manufacturer incoming goods control. Please contact our service/sales department if additional questions

### **Approved packaging methods/materials:** (Applies to all shipments to manufacturer)

When returning goods, please make sure you surround the product with the following material, whenever possible: Original packaging from manufacturer, firm foam material, bubble wrap or lots of PadPack paper or Foam chips/polyester wrapped in sealed plastic bags. In any case, always use a solid cardboard box to surround everything.

Not approved packaging methods/materials are: Foam chips, expanded polyester, clothes, nothing, or too little, or anything that will crumble and get into the ventilation holes of products and cardboard boxes that are not suitable to secure the product during shipment.



## Terms Of Sale And Delivery

### 1) APPLICATION

The terms of sale and delivery apply for Hatteland Display.

### 2) PRICE

- a) The price is per each, if nothing else has been stated, VAT not included. Price is based on the prices from our suppliers, current custom rates, taxes, rate of exchange and international raw material prices. We reserve ourselves the rights to adjustments in case of alternation on the above mentioned.
- b) Included in the price is the supplier's standard packing. In case of re-packing/smaller quantities we reserve ourselves the right to add an additional sum for warrantable packing according to CECC 0015 (Basic inspection for protection of electrostatic sensitive devices)

### 3) VALIDITY

If nothing else has been stated in our quotation, the offer is valid for 30 days from the date of quotation.

### 4) PACKAGE QUOTATION

A package quotation means that all the components offered, must be ordered by us. If one component or more are removed from the quotation, the prices given in the package quotation are not valid.

### 5) TERMS OF PAYMENT

Cash on delivery or payment in advance. Net granted for companies, schools and institutions only, according to agreement. In case of too late payment 1.5% interest/month will be charged. Seller has mortgage rights in the goods delivered until the purchase price, additional interests and charges have been paid in full. Accepted bill is not considered as payment until it has been honoured in full.

### 6) TIME OF DELIVERY

The quoted time of delivery is based on information from our suppliers. We disclaim any responsibility for the consequences of any delay or cancellation from our suppliers. Belated delivery gives not solely the right for cancellation.

### 7) DELIVERY POINT OF TIME

Goods are considered delivered to customer when handed over to charterer.

### 8) FREIGHT / PACKING / FORWARDING FEE

Hatteland Display AS charge NOK 50,- in forwarding fee for orders below NOK 1000,-.  
Freight charge according to expenses for orders above NOK 1000,-. VAT not included.

### 9) COMPLAINT

By receipt customer must check goods for obvious defects which have to be claimed within 8 days from receipt. Otherwise acceptance of complaint can not be counted on.

### 10) GUARANTEE / SERVICES

Time of guarantee is calculated from our date of shipment, and applies to the extent that we are covered by our supplier's guarantee regulations. The guarantee does no longer apply if:

- I) there has been encroached upon the goods without seller's consent
- II) terms of payment is not fulfilled
- III) the goods have been damaged due to unskilled treatment
- IV) components which are sensitive for static electricity have not been unpacked and treated in a secure way.

Minimum requirements: CECC 00015's standards for handling of such components. The guarantee does not include fair wear and tear.

### 11) RESPONSIBILITY

Seller undertake to deliver faultless and functional capable goods according to existing technical specifications. Seller disclaim responsibility for any damage or loss which directly or indirectly may be caused due to failure or defect with the delivered goods, if carelessness from the seller can be limited up to the cost of the goods. The supplier's responsibility for defects with the supplied goods do not include secondary damage or loss.

# Terms

## 12) CANCELLATION / RETURN

Binding sales contract is concluded when we have confirmed customer's purchase order. Any disagreements in our order confirmation must be reported to seller within 6 days. The agreement can not be altered without our permission, after acceptance from our supplier. If goods are wanted to be returned, a Return No must be assigned from seller. Returned goods without a Return No will not be accepted. By return of stock listed goods, 20% return fee is charged. Returned goods are shipped on customer's account and risk.

## 13) LOAN, RENT and DEMO

When borrowing of goods for demo/test, the date of return must be added to the document. If no date has been stated, date of return is two weeks from the date of the document. Before return, seller must be contacted for a Return No (RTK). Goods which have been sold with an agreed right of return within stated terms, shall also have a Return No. The Return No must be obtained before the stated date of return. Returned goods without a Return No, or which have not been packed in original packing, will not be accepted.

## 14) LIMITATIONS

If any of our suppliers claim limited delivery terms towards us, our terms of delivery will be restricted according to those.

## 15) SOFTWARE

Sold or borrowed software is not allowed to be copied or spread in other ways, without a written permission.

## 16) RE-EXPORT

Goods delivered from seller may be subject to special rules of exportation in their supplier's native country. Buyer is responsible to obtain necessary permissions for further export/re-sale.

## 17) QUESTION IN DISPUTE

To settle any dispute the Karmsund Herredsrett is approved the legal venue.

## INSTRUCTIONS FOR THE CONSIGNEE

### 1) CONTROL

Control the goods immediately by receipt. Examine the quantity towards the invoice/packinglist/shipping documents. Look for outward defects on the packing which may indicate damage on or loss of contents. Control the container and the seals for any defects.

### 2) SECURING EVIDENCE

When defects on the goods have been found, evidence must be secured, and seller must be informed. Call the transporter and point out the defects. Add a description of the defects on the goods receipt, the forwarder's copy of the way-bill or on the driving slip.

### 3) RESCUE

Bound the damage. Try to restrict the damage and the loss. Seller will compensate expenses incurred due to reasonable security efforts in addition to damage and loss.

### 4) COMPLAINT

Write immediately a complaint to the transporter or his agent. Forward immediately the complaint to the transporter or his agent, and hold the transporter responsible for the defects. The complaint must be sent at the latest:

- for carriage by sea: within 3 days
- for overland / air transportation within 7 days

### 5) DOCUMENTATION

For any claims the following documentation is required, and must be forwarded to the company or their agent: invoice, way-bill and/or bill of landing, and/or statement of arrival, inspection document, besides a copy of the letter of complaint to the transporter.

# Pixel Defect Policy

## PIXEL DEFECT POLICY

### Dot-defects (Bright or dark spots on the panel)

Due to the effect that dot failures are part of the TFT technology such failure occurrence cannot be prevented basically. Even though dot defects usually occur during production process, new defects can appear within the lifespan of a TFT display. Neither the production at LCD-supplier nor the use of a LCD-Monitor after shipment can be influenced by Hatteland Display. Hence Hatteland Display cannot be made responsible for such dot failures. However Hatteland Display understand and accepts the responsibility towards the customers for the delivery of new displays, therefore accepts a limitation on dot defect's occurrence on new displays delivered to the customer.

## PRINCIPLES

- a. One pixel consists of 3 dots (Red, Green and Blue)
- b. Dot defects are differentiated between:
  - Bright dot defects: Spot on the panel appear as pixels or sub pixels that are always lit. Non-extinguishing dot.
  - Dark dot defects: Spot on the panel appear as pixels or sub pixels that are always dark (off). Non-lightening dot.
- c. Inspector observes the LCD from normal direction at a distance of 50cm above the worktable. Dark dots are counted under entire white screen. Bright dots are counted under entire black screen.
- d. Dot failures within tolerances below do not qualify for warranty claims.

## PIXEL DEFECT TOLERANCES

Bright dot	≤ 4 dots
Two adjacent bright dots *	≤ 2
Distance between 2 dot defects *	≥ 15mm
Dark dots	≤ 8
Total number of bright or dark dot defects. *	≤ 8

\* 1 or 2 adjacent dot defects considered as 1 defect.

## EXTRAORDINARY CIRCUMSTANCES

Possible cases which cannot be influenced either by customer or Hatteland Display.

### Examples for extraordinary circumstances:

- Allocation from LCD-Supplier
- Outstanding high number of LCD-panels with bright dots but within LCD-suppliers Specification.
- Sharply increased demand by customer

**In such cases a mutual agreement is inevitable.**

### Examples:

- Acceptance of bright dots in "non-critical" display areas.
- Acceptance of bright dots with defined color.

IND100351-1 - Rev 2 - Jul 2007

## Notes

### **General Notes:**

- The unit is type approved according to EN60945 (1997), 4.4, equipment category b) protected from the weather.
- Use of brightness and push buttons may inhibit visibility of information at night.

# Revision History

Rev.	By	Date	Notes
1	SE BU KO MH	17 Jul 2009	Customized manual. Based on INB100036-1 manual. Own note for FUD models added. For internal and preliminary customer review.
2	BU SE	27 Aug 2009	Revised Product Labels (page 12) OSD H and V pos defaults set to 100 (page 38-39)
3	SE JK TØ BU GV	05 Feb 2010	Added Introduction to displays (from INB100036-1) (page 10) Revised installation chapter regarding Rotary + Mounting Bracket & added mounting illustrations (page 19) Rewrite text regarding "Hotkeys" and "Direct Access" (page 25,43) Fixed typing error "Display Data Configuration" to "Display Data Channel" (page 42) Removed references to ECDIS models, xxE-xxxx. (page 1,48,49,50) Removed LRS (pending) from 15, 19 and 20 inch specifications. Not to be performed (page 48,49,50)

