

SMART™ SENSOR

# UST800/UST850 Smart™ Sensor

## Ultrasonic Smart™ Sensor for Cruising and Racing

AIRMAR's new UST800/UST850 just turned your maintenance time into more cruising time...and made your boat smarter too. Ultrasonic speed and temperature in one single housing with no moving parts makes this sensor a high precision, low maintenance solution for use on power and sail boats of all types and sizes. Say goodbye to paddlewheel maintenance and hello to Smart technology, from the company who invented the Smart™ Sensor.

### Features:

- Ultrasonic Speed & Temperature in one housing with no moving parts
- Advanced filtering and sampling rates for increased accuracy at all speeds
  - Data update rate up to 10 x per second
  - Speed Range (0.1 to 50 knots)
- Adapts automatically to increases in speed so accuracy remains constant

**We've got you covered.**



**AIRMAR®...IT'S WHAT'S UNDER YOUR BOAT.**

**AIRMAR®**  
TECHNOLOGY CORPORATION

# Improved Performance

## **Paddlewheel maintenance... a thing of the past**

With an ultrasonic speed sensor, paddlewheel maintenance becomes a thing of the past. Enjoy the performance advantage of ultrasonic speed which updates faster and provides maintenance-free reliability all season. AIRMAR's UST800/850 features patented Adaptive Signal Processing which provides unmatched speed sensitivity that adjusts to the speed, depth and water clarity. All this with no paddlewheel to pull and maintain... AIRMAR just turned your maintenance time into more cruising time!





# Features

## High Precision Speed

The state-of-the-art processor in the UST800/UST850 calculates speed up to 22 times every second, so it can respond to rapid changes in vessel speed. This translates into the most reliable and accurate ultrasonic speed sensor on the market—at a very competitive price.

### Speed Range

0.1 to 50 knots (57 MPH)

### Available Outputs

—NMEA 0183

—NMEA2000®

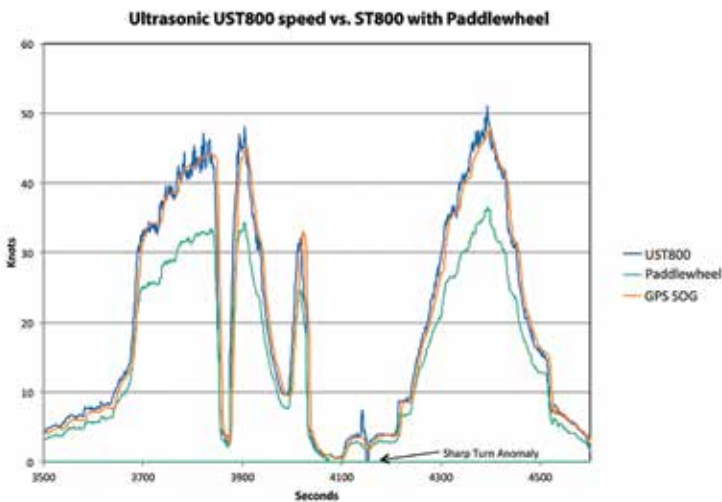

## Fast Response Water Temperature

With accuracy of  $+0.5^{\circ}\text{C}$  ( $+1.0^{\circ}\text{F}$ ), the UST800/UST850 makes searching for optimum swimming and fishing temperatures easy.

### Water Temperature Range

$-4^{\circ}\text{C}$  to  $40^{\circ}\text{C}$  ( $24.8^{\circ}\text{F}$  to  $104^{\circ}\text{F}$ )

## NMEA Compatible

AIRMAR is a long-time, integral partner with the National Marine Electronics Association (NMEA), both in providing sensor solutions and aiding in the development of NMEA standards. With over 15 certified sensors providing depth, speed, temperature, weather, heading and GPS data, our sensors provide reliable, accurate information for navigational needs. AIRMAR continues to focus on the development of innovative sensor solutions.

## Echo Correlation Processor

The UST800/UST850's echo correlation processor has patented adaptive digital signal processing that automatically adjusts according to boat speed, water depth and water clarity for most accurate speed readup. Reliable operation in both salt and fresh water.

## Simple Installation and Easy Maintenance

Only one hole through the hull simplifies the installation—an attractive feature for boat builders and boat owners alike.

### UST800

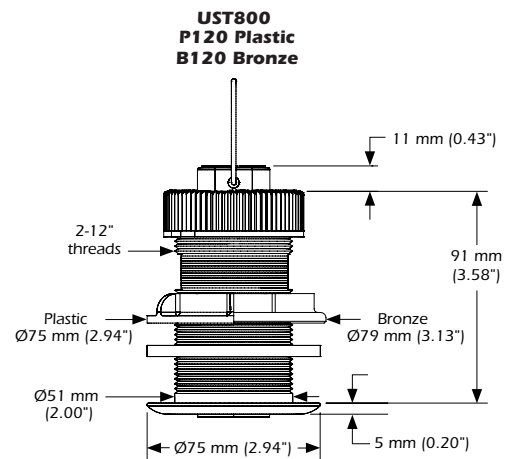

### UST850

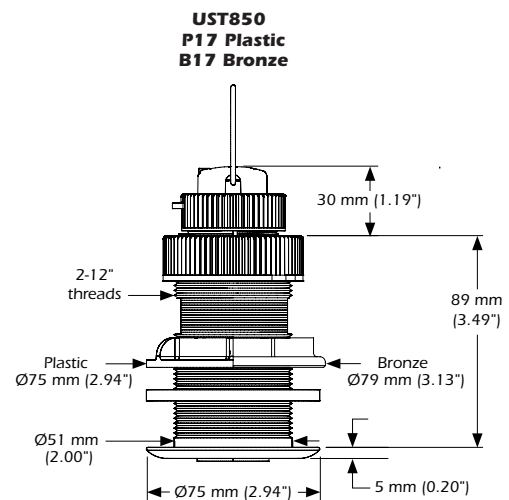

# UST800/UST850 SMART™ SENSOR



## Technical Information

### SPECIFICATIONS

Correlation Speed Sensor Transmitting Frequency	4.5 MHz
Pulse Repetition Frequency	0.5 kHz to 12 kHz (varies with speed)
Speed Range	0.1 to 50 knots (57 MPH)
Available Outputs	NMEA 0183 or NMEA2000®
Water Temperature Range	-4°C to 40°C (24.8°F to 104°F)
Water Temperature Accuracy	+0.5°C (+1.0°F)
Supply Voltage	9 VDC to 16 VDC
Supply Current	80 mA - 200 mA, Average 125 mA @12VDC
Thru-Hull Housing Material	Plastic, bronze or stainless steel
Thru-Hull Housing Diameter	51 mm (2")
Sensor Material	Plastic insert
Blanking Plug	Yes
Weight	1.4 kg (3 lb)—Plastic 1.8 kg (4 lb)—Bronze
CE Compliant	Yes

Part numbers: UST800: 44-202-1-01  
UST850: 44-195-1-01

### PROCESSOR BOX CONFIGURATIONS

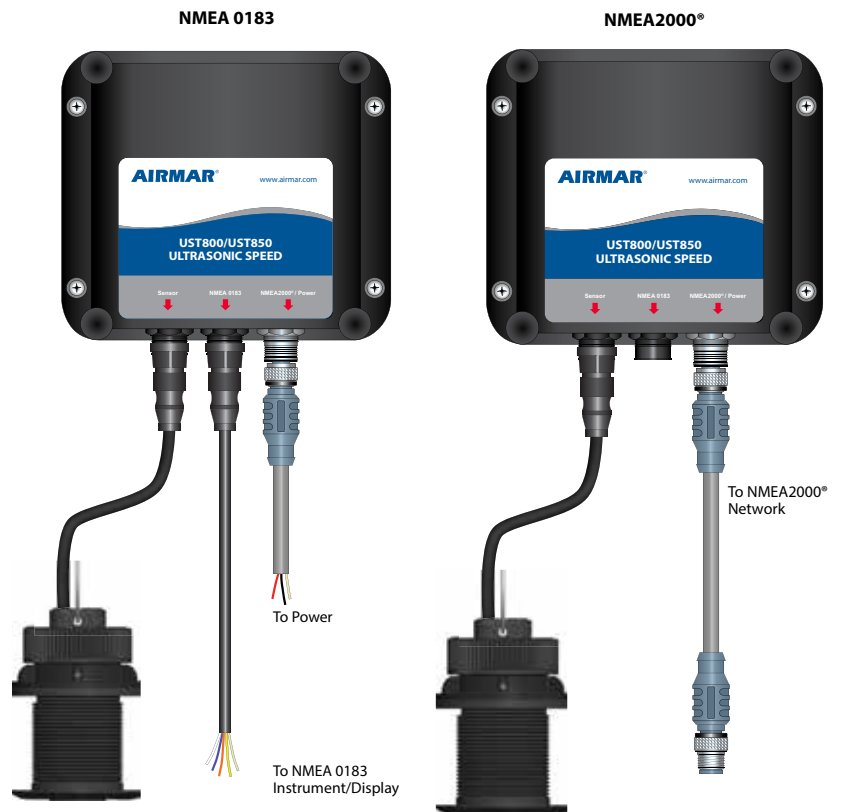

[www.airmar.com](http://www.airmar.com)

©2017 AIRMAR Technology Corporation

UST800/UST850\_rE 9/15/17

As AIRMAR constantly improves its products, all specifications are subject to change without notice. All AIRMAR products are designed to provide high levels of accuracy and reliability, however they should only be used as aids to navigation and not as a replacement for traditional navigation aids and techniques. Smart™ is a trademark of Airmar Technology Corporation. Other company or product names mentioned in this document may be trademarks or registered trademarks of their respective companies, which are not affiliated with AIRMAR.

